



# MIXOLOGY & GASTRONOMY

Türkçe - English - Deutsch

**ADNAN MERT BARANTICO**

## ADNAN MERT BARANTICO

Eđitimi: Bursa - Tophane Endüstri Meslek Lisesi, Inlingua Sprachschule 1 yıl, Goethe Institut 2 yıl, Hotelfachhochschule Kermess - München / Ger. 1 yıl, training 1 yıl, Deutsches Weininstitut Mainz. / Ger. 3 ay, Chaine de Rotisseurs, Paris / Fra. 1 hafta, Uludađ Üniversitesi Turizm Meslek Yüksekokulu Öğr.Gör. 2 yıl.

Profesyonel Turist Rehberi - Yazar Adnan Mert - Barantico, doğma büyüme Bursalı olup tam bir Bursa sevdalısıdır. Yazar Adnan Mert-Barantico 6 eser yazmış olup, 5. Akademik eseri Gastronomy - Mixology'yi 20 yılda 3 dilde (Türkçe-English-Deutsch) yazmıştır. Bu sefer 6. & son, ustalık & gözde eseri olan "Geçmişe Yolculuk - Journey to the Past" kitabını akıcı bir şekilde 10 yılda sanat tarihçileri ile birlikte, tarihe özellikle erken dönem Osmanlı tarihine olan ilgisi & Bursa şehrine olan sevgisi sayesinde 2 dilde (Türkçe-English) kaleme dökmüştür..

Halen Bursa`da ruhsatlı, eylemli, kokardlı profesyonel turist rehberliği yapmaktadır. Bursa Rehberler Odası'nın faal üyesidir. Kılıç & Kalkan'a merakı çocukluğunda seyrettiđi Zorro & 3 Silahşörler filmlerinin etkisinde kalarak, eskrim dersleri de alarak, kendini Osmanlı kılıçları üzerine verdi, Bursa'daki 5 Kılıç & Kalkan folklor derneklerinin 3`ünde oynayarak dünyanın birçok ülkesinde Türkiye'yi temsil etmiştir. Judo hakemliği, spor masörlüğü/ sport masseur, fitness & halk oyunları, Osmanlı kılıçları ile kargı resmi antrenördür. 15 yaşında başlayan motorsiklet tutkusu günümüzde halen faal olarak devam etmektedir. Bursa Tüyap fuar alanında Barantico ailesi 14 yıl gastronomy işletmeciliđi yapmışlardır. Bursa Choppersclub`ın faal üyesiydi, Selçuklu-Osmanlı kılıçları, kalkanları, piştovları, kostümleri koleksiyoneridir. Bursa`da müze ofis-misafirhanesi vardır.



ISBN. : 975 - 94912 - 1 - 4



## ADNAN MERT BARANTICO

### Education

High School: Tophane Industrial High School, Bursa

University: Uludağ University - Tourism Business school - 2 years

Hotelfach Hochschule Kermess München - 1 Year

Language: Ilingua Sprachschule - 1 year

Goethe Institute - 2 years

Expertise: Deutsches Weininstitut Mainz - 3 months

Chaine de Rotisseurs Paris - 1 Week

### About Adnan Mert,

Professional Tour Guide / Author, Adnan Mert - Barantico was born in Bursa and loves Bursa by heart. He completed so far 6 books and the 5<sup>th</sup> academic work "Gastronomy – Mixology" is a result of 20 years of work. It is available in three languages; Turkish, English, German. His last work, authored in novel narration form "Journey to the Past" of 20 years of work and was created in collaboration with art historians and blend with his commitment to early Ottoman history and his passion for Bursa. It is available both in Turkish and English languages.

Adnan Mert is still an active and certified professional tour guide in Bursa. He is an active member of the Bursa Tour Guides Chamber. His is a master in "Kilic and Kalkan" meaning "Sword and Shield" (a traditional Bursa folk dance, performed with the harmonies movements of the sword and shield. He was inspired from the movies Zorro, and The Three Musketeers which he saw during his youth; later leading to fencing lessons and specializing in Ottoman blades and swordsmanship. Mr. Mert, member of three different folk associations in Bursa, represented Turkey abroad, in many countries with Kilic and Kalkan.

Additionally, Mr. Mert is a certified trainer for Judo, Sport Massage, Fitness, Folk Dance, Ottoman Swordsmanship and Javelin. Apart from this, he was an active member of Bursa Choppers Club as he is an active motorcycle rider and an avid enthusiast since age 15.

He also founded and operated the Barantico Gastronomy Restaurant in Bursa for 14 years.

As a collector Mr. Mert has a considerable collection of Seljuk/Ottoman Swords, Shields, Pistols and Costumes which he exhibits in his private museum in Bursa, Turkey.



## İÇİNDEKİLER / CONTENTS / INDEX

Index.....	04
Cocktails-Index /Inhalts / İçindekiler .....	05
Ön söz / Foreword / Vorwort - Adnan Mert .....	10
500 Yıllık, Tarihi Arapşükrü Sokağı - Yahudilik, Bursa'nın Kumkapısı .....	15
Yiyecek içecek servisi & metodları.....	28
Flambé / Alevlendirme Flambiért .....	30
Cocktail Tarihçesi / Cocktail & Seine Geschichte.....	32
Brandy'nin tarihçesi / Historisches vom gebrannten wein.....	38
Cocktails (Türkçe - Turkish).....	48
Coctails (Deutsch).....	58
Coctails (English).....	68
Mix.-Lexicon, Turkish, Deutsch .....	76
Berry / Beere / Çilek, Dut / Fruits / Obst / Meyveler (in 6 languages) lexicon ...	116
Fish / Balık lexicon (in 15 languages) .....	117
Spirits / Spirituosen-lexicon.....	119
Kütüphane / Library / Bücherei-literatur (in 6 languages).....	126
Bar measures / barmaße / Bar ölçekleri .....	133
Glass Terminology / Glas Terminologie .....	137
Bar Plans / Bar Planları.....	145
Table / Tafel , Tisch / Sofra, Masa-Form .....	157
Peçete katlama / Servietten falten / Nnapkin to fold, Napkin folden .....	160
Glasses / Gläser / Bardaklar - Form.....	168
Menu Cover-form / Menu Gedeckt, Deckel / Kuver-form .....	170
Rodop Köftesi'nin Tarihçesi.....	183
Kitchen / KüChé / Mutfak-lexicon / Internatinal Kitchen.....	188
Ice-creams / Eis, Eiscreme, Eis-Sorten / Galati / Dondurmalar .....	257
Dondurma bardak / Kupa Terminolojisi.....	268
Master Menu Guide / Menu Führer / Menu Rehberi .....	271
Cocktails / Kokteyller.....	277
References / Referenzen / Referanslar .....	346
Photos / Fotoğraflar.....	347





## Reçete, Recio

Art.Nr.		page / seite / sayfa		
01	ACAPULCO .....	277	51	BAMBOO..... 283
02	ADIDAS DRINK.....	277	52	BEACH DREAM..... 283
03	AFTER DINNER .....	277	53	BARRACUDA..... 283
04	ALASKA.....	277	54	BANANA & MILK..... 283
05	ALEXANDRA.....	277	55	BROWN COW..... 283
06	AMERICANO.....	278	56	BERRI TA..... 284
07	AMERICAN GLORY.....	278	57	BEAU SITE..... 284
08	ANGELA.....	278	58	BIG BOY..... 284
09	ANGEL FACE.....	278	59	BOMBAY..... 284
10	AMERICAN.....	278	60	BONGO COCKTAIL SP. .... 284
11	ANNA & SIBER .....	278	61	BODY BUILDING..... 284
12	APPETISER.....	278	62	BURSA SWORD-SHIELD C. .... 284
13	SİRİNÉ.....	278	63	BRONX A, B..... 285
14	ASBACH-MANHATTAN.....	279	64	BRANDY SODA..... 285
15	ASTORIA.....	279	65	BRANDY COLA..... 285
16	AYDA.....	279	66	BRANDY..... 285
17	ASLIM.....	279	67	BIJOU..... 285
18	ARACAJU COCKTAIL.....	279	68	BLACK HAWK..... 285
19	APRICOT COCKTAIL.....	279	69	BLACK RUSSIAN..... 285
20	APRI TOP.....	279	70	BLUE LADY..... 285
21	ALASKA.....	279	71	BUTTERFLY..... 285
22	B & B.....	280	72	BRANDY ALEXANDER..... 285
23	BLUE BACALICA.....	280	73	BREAKFAST..... 286
24	BOBBY BURNS.....	280	74	BRIDGE CLUB..... 286
25	BETWEEN THE SHEETS.....	280		<b><u>BEER COCKTAILS</u></b>
26	BOKMAN SPECIAL.....	280	75	BEER PUNCH..... 286
27	BRIAN CORCOVADO.....	280	76	CHURCHILL..... 286
28	BAHIA A, B.....	280	77	EROTIC BEER..... 286
29	BATIDA COCKTAIL.....	280	78	RADLER / SHANDY..... 286
30	BBC.....	280	79	SEXY COWBOY..... 286
31	BANANA ROYAL.....	280	80	TOWARISH..... 286
32	BANANA BLISS.....	281	81	TROPIC BEER..... 286
33	BANANA BOAT.....	281		<hr/>
34	BÉNÉDICTINE.....	281	82	CAMPARI..... 286
35	BÉNÉDICTINE TONIC.....	281	83	CAMPARI ORANGE..... 286
36	BÉNÉDICTINE YELLOW JACKET.....	281	84	CAMPARI SODA..... 286
37	BÉNÉDICTINE SUNDOWNER.....	281	85	CAPTAIN SILVER..... 287
38	BÉNÉDICTINE VERFUHRUNG.....	281	86	CARDINAL..... 287
39	BÉNÉDICTINE SUNBURST.....	282	87	CARUSO A, B..... 287
40	BÉNÉDICTINE FRENCH CLASSIC.....	282	88	CHARLESTON..... 287
41	BÉNÉDICTINE DUC DE NORMANDIE.....	282	89	CHARLIE CHAPLIN..... 287
	<b><u>MONIN COCKTAILS</u></b>		90	CHERRY BLOSSOM..... 287
	(with or non alcoholic drinks)		91	CHERRY BRANDY..... 287
42	BLUE PASSION.....	282	92	CHIC & SHOCK..... 287
43	BANCO.....	282	93	CLARIDGE..... 287
44	BANDOLERO.....	282	94	CLUB..... 288
45	BABY SPECIAL.....	282	95	COLONIAL..... 288
46	BACARDI.....	283	96	COCO COLA MINZE..... 288
47	BARBARA.....	283	97	CRAZY BARMAN..... 288
48	BARBARELLA.....	283	98	CUBA LIBRE..... 288
49	BANCO.....	283	99	CYNAR SODA..... 288
50	BADEN BADEN.....	283	100	CYNAR ORANGE..... 288



### COBBLERS

101	BRANDY	288
102	CHAMPAGNE	288
103	MELONEN COBBLER	288
104	SHERRY	289

### COCKTAILS WITH CHAMPAGNE

105	AMERICAN GLORY	289
106	APEROL ROYAL	289
107	BELLINI	289
108	BLUE MOON SP.	289
109	BLUE TANGO	289
110	BLUE CHAMPAGNE	289
111	BLUE HEAVEN	290
112	BRIGADE	290
113	CHICAGO COCKTAIL	290
114	CHAMPAGNE COCKTAIL	290
115	CÔTE D'AZUR	290
116	CRAZY HORSE	290
117	CRUSTINO	290
118	BACHUS	290
119	FRENCH 75	290
120	FRENCH CONNECTION	290
121	FROZEN CARUSO C	291
122	FLYING	291
123	GOLDEN MONOPOLE	291
124	GOLDEN LADY	291
125	I.B.U.	291
126	KIR ROYAL	291
127	LEO'S SPECIAL	291
128	MINT-COCKTAIL	291
129	MONTE CARLO	291
130	MONINO	291
131	MOULIN ROUGE	292
132	MIMOSA A, B	292
133	MY FAIR LADY	292
134	OHIO	292
135	PETITE FLEUR	292
136	PRINCE OF WALES A, B	292
137	PEACH LADY	292
138	RED KISS	292
139	THE BUFFALO BILL	292
140	TURKEN BLUT	292

### COLLINS

141	TOM COLLINS A, B	293
142	JOHN COLLINS	293
143	BACARDI COLLINS	293

### COOLERS

144	PICCOLO COOLER	293
145	CARIBBEAN COOLER	293
146	SCOTCH COOLER	293

### CRUSTAS

147	DAWN CRUSTA	294
148	BRANDY CRUSTA	294

### CUPS

149	CLARET CUP	294
150	CIDER CUP	294
151	DAIQURI A, B, C, D, E	294
152	DALTON BROTHERS	296
153	DEAUVILLE	296
154	DISCO NIGHT	296
155	DIXE	296
156	DRAMBUJE TONIC	296
157	DOCTOR	296
158	DUCHESSE	296

### DAISIES

159	BRANDY	296
160	BRANDY DAISY	296
161	GIN	296
162	VODKA DAISY	296

### DESSERT COCKTAILS

163	BLUE MOON	297
164	FIFTH AVENUE	297
165	GRASSHOPPER	297
166	GOLDEN CADILLAC	297
167	GOLDEN DREAM	297

### DIGESTIFS

168	BRANDY PORT	297
169	GODFATHER	297
170	GOLDEN NAIL	298
171	RUSTY NAIL	298
172	VODKA STINGER/CORPSE REVIVER	298

### DIVERSE DRINK

173	APRICOT BLOSSOM	298
174	ATOM AMERICANO	298
175	SCREWDRIVER Tornavida	298
176	ORANGE BLOSSOM	298
177	Phar./Apoth./Ecz.Yazan's Spc.	298
178	ELIZABETH & KISS ME	298
179	EL DIABLO	299
180	EL DORADO	299
181	EMPIRE	299

### EGG-NOGS

182	BALTIMORE EGG-NOG	299
183	BREAKFAST EGG-NOG	299
184	EGG-NOG A, B	299
185	PICCOLO-NOG	300
186	FAVORITE	300
187	FIRST LOVE A, B	300
188	FLAMINGO	300



189	FRENCH COCKTAIL.....	300
190	FRUIT COCKTAIL.....	300

### FRAPPES

191	PFEFFERMINZ FRAPPÉ.....	300
192	NAP FRAPPE.....	300

### FIXES

193	BRANDY FIX.....	301
194	GIN FIX.....	301

### FIZZES

195	APRICOT FIZZ.....	301
196	BACARDI FIZZ.....	301
197	DRAMBUIE FIZZ.....	301
198	DUBONNET FIZZ.....	301
199	GIN FIZZ.....	302
200	GRAPEFRUIT FIZZ.....	302
201	GREEN FIZZ.....	302
202	ORANGE FIZZ.....	302
203	PFEFFERMINZ FIZZ.....	302
204	TEXAS FIZZ.....	302

### FLIPS

205	BRANDY FLIP.....	303
206	BOSTON FLIP.....	303
207	CHAMPAGNE FLIP.....	303
208	DAMEN-HERREN FLIP.....	303
209	MOCCA FLIP.....	303
210	PORTO FLIP.....	303
211	ROSÉ FLIP.....	303
212	SHERRY FLIP.....	303
213	GIN.....	304
214	GIN-BITTER LEMON.....	304
215	GIN-CHERRY JUICE.....	304
216	GIN-GRAPEFRUIT JUICE.....	304
217	GIN-MANDARIN JUICE.....	304
218	GIN-COLA.....	304
219	GIN-GRENADEAPPLE J.....	304
220	GIN-MELON JUICE.....	304
221	GIN-WATERMELON J.....	304
222	GIN MENTHE.....	304
223	GIMLET.....	304
224	GIPSY.....	304
225	GOLDEN GLEAM.....	304
226	GOLDEN COCKTAIL.....	304
227	GOLDEN DAISY C.....	304
228	GOLDEN DREAM.....	304
229	GOLDEN MONOPOLE.....	304
230	GOGEL-MOGEL.....	305
231	GRAND MARNIER-TONIC.....	305
232	GREEN BURSA.....	305
233	GREEN DRAGON.....	305
234	GREEN SEA.....	305
235	GREEN EYES.....	305

236	GREEN PEACE.....	305
237	GREEN HAT.....	305
238	GREEN BANANA.....	306
239	GRÜNE WITWE.....	306
240	CRAZY THINK'S A LOVE.....	306
241	HAPPY BACARDI.....	306
242	HARMAN DALI.....	306
243	HALF & HALF.....	306
244	HARVEY WALLBANGER.....	306

### HIGHBALL

245	BOURBON HIGHBALL.....	307
-----	-----------------------	-----

### HOT DRINKS

246	CAPPUCCINO.....	307
247	GRAND MARNIER.....	307
248	COFFEE OLATE.....	307
249	EXOTIC COFFEE.....	307
250	FRENCH COFFÉE.....	307
251	FUROR BAVARICUS.....	307
252	GROG.....	307
253	HALB & HALB.....	308
254	HOLLAND COFFEE.....	308
255	IRISH COFFEE.....	308
256	LUMUMBA.....	308
257	MALIBU HOT CHOCOLATE.....	308
258	MULLED WINE.....	308
259	PHARISAER COFFEE.....	308
260	TEA OLATE.....	308

261	ICED TEA.....	308
262	IPANEMA COCKTAIL.....	308

263	JAMAICA DREAM.....	308
264	JUNGLE JUICE.....	309

### JULEPS

265	MINT JULEP A, B.....	309
266	BRANDY JULEP.....	309

267	K-C 25 COCKTAIL.....	309
268	KAMIKAZE.....	310
269	KANGAROO.....	310
270	KEHRAUS.....	310
271	KIKU KIKU.....	310
272	KIRKANBAR.....	310
273	KISS ME QUICK.....	310
274	LADY.....	310
275	LADY IN AMAZON.....	310
276	LARA.....	310
277	LOVE HOME.....	311
278	LOVE ELIXIR TO MAITE.....	311
279	LONG ISLAND ICE TEA.....	311
280	MANHATTAN A, B.....	311



281	MARGARITA A, B	311
282	MARY OF SCOTLAND	311
283	MASCOTTE	312
284	MALIBU TONIC	312
285	MALIBU BITTER LEMON	312
286	MALIBU ORANGE	312
287	MALIBU COLA	312
288	MALIBU WITH MILK	312
289	MALIBU	312
290	MARABA COCKTAIL	312
291	MARTINI	312
292	MARTINI EXTRA DRY. & BITTER ORANGE	312
293	MARTINI ROSSO & COLA	312
294	MARTINI BIANCO & TONIC	312
295	MERRY WIDOW	313
296	MILANO-PARIS	313
297	MUNCHEN-BURSA LINE	313
298	MOMO	313
299	MONT BLANC	313
300	MORNING GLORY	313
301	MYRA COCKTAIL	313

### MARTINIS & GIBSONS

302	MARTINI USA TYPE	A	313
	MARTINI DRY	B	314
	MARTINI VERY DRY	C	314
	DRY.MARTINI C.	D	314
	SWEET MARTINI C.	E	314
	MARTINI SWEET	F	314
	MARTINI MEDIUM	G	314
	MARTINI ENGLISH	H	314
	MARTINI C. DRY	I	314
303	MARTINI-STEINHÄGER		314
304	MALINI		314
305	FIFTY - FIFTY		314
306	GIBSON		315
307	VODKA GIBSON		315
308	VODKATINI		315
309	NEGRONI A, B, C		315
310	NELSON		315
311	NEW ORLEANS		315

### NON-ALCOHOLIC COCKTAILS /

#### MOKTAILS

312	ADIDAS DRINK	315
313	BALLERINA	315
314	BANANA-FLIP	316
315	BANANA-MIX	316
316	BOBBY	316
317	BURSA SWORD-SHIELD COCKTAIL	316
318	CARO AS	316
319	CHAPALA	316
320	COCO KISS	316
321	CREOLE-COOLER	316
322	EVIMIM	316
323	FLORIDA-FLIP	317

Art.Nr.		page / seite / sayfa
324	FLORIDA	317
325	FRUIT COCKTAIL	317
326	4 FRUIT COCKTAIL	317
327	GESUNDHEIT	317
328	GRAPEFRUIT / HIGHBALL	317
329	GRENADINE-LEMONADE	317
330	KIRKANBAR	317
331	LEMONMILK	317
332	MIAMI	317
333	NAPOLI	317
334	PUSSY CAT	317
335	PICCOLO-FLIP	318
336	SPEZI	318
337	ULUDAG	318
338	VIRGIN MARY	318

### NON ALCOHOLIC COCKTAILS

#### WITH MONIN

339	EMERUDE	318
340	EXOTIC BLUE	318
341	FIZZY FIRE	318
342	GREEN SUMMER	318
343	GRÜNE WITVE	318
344	GRÜNSCHNABEL	319
345	KENTUMI	319
346	LIBERTINE	319
347	PUFFO	319
348	SUMMER GARDEN	319
349	SWEET DREAMS	319
350	OLD FASHIONED	320
351	OLYMPIA	320
352	OLYMPIC	320
353	ONE EXCITING	
	NIGHT A, B	320
354	OPERA	320

#### OYSTERS

355	GIN OYSTER	320
356	INDIANA OYSTER	321
357	PARADISE A, B	321
358	PARAMISE	321
359	PEMBE RUYA	321
360	PERFECT	321
361	PINK GIN	321
362	PINK NIGHT	321
363	PINK LADY A, B	321
364	PINK PEARL	321
365	PIMMS NO 1	322
366	PINK ROSE	322
367	PLUIE D'OR	322
368	PRESIDENT A, B	322
369	PRESIDENTE	322
370	PRINCE CHARLIE	322
371	PROF'S GIN	322



<u>PICK ME UPS</u>		
372	MATRIOWSKA.....	322
373	BLOODY MARY.....	323
374	GRAND MARNIER PICK ME UP.....	323

<u>POUSSE-CAFÉS RAINBOW COCKTAILS</u>		
375	ANGEL'S DELIGHT.....	323
376	TURKISH DELIGHT.....	323
377	ANGEL KISS.....	323
378	B-52.....	323
379	B-62.....	323
380	EIERMÄNNCHEN.....	324
381	FINNLANDIA.....	324
382	GRASSHOPPER.....	324
383	JUNGBRUNEN.....	324
384	MARIA TERESA.....	324
385	POUSSE CAFÉ.....	324

<u>PUNCHES</u>		
386	ASBACH-PUNCH.....	324
387	BUDDHA-PUNCH.....	324
388	CLARED-PUNCH.....	325
389	HOT RUM-PUNCH.....	325
390	PLANTERS-PUNCH.....	325
391	POSTDAMER-PUNCH.....	325
392	RED KISS.....	325
393	RED LION.....	325
394	RED TONIC.....	325
395	ROB ROY.....	325
396	ROLLS ROYCE.....	325
397	ROSEÉ.....	326
398	ROSE A, B.....	326
399	ROC-A-COE.....	326
400	ROYAL.....	326
401	SELIN.....	326
402	GIN RICKEY.....	326
403	RUM RICKEY.....	326
404	SANTOS COCKTAIL.....	326
405	SAFARI ADVENTURE.....	327
406	SCORPION.....	327
407	SEA SUN SEX.....	327
408	SEXY PICCOLO.....	327
409	SEX ON THE BEACH.....	327
410	SHANGAI.....	327
411	SHAKERATO.....	327
412	SIDE CAR A, B.....	327
413	SILVER.....	327
414	SINGAPORE SONG.....	328
415	SNOWBALL.....	328
416	SONIA COCKTAIL.....	328
417	SPRIT OF SCOTLAND.....	328
418	SKY DIVER.....	328
419	STANLEY.....	328
420	STAR.....	328

Art.Nr.		page / seite / sayfa
421	STINGER.....	328
422	SULTAN COCKTAIL.....	328
423	SWEET LADY.....	328
424	SWEET LOVE.....	328

<u>SANGRIA &amp; PARTY DRINK</u>		
425	MALIBU SUNSET.....	329
426	SANGRIA.....	329

<u>SANGAREES</u>		
427	BRANDY SANGAREE.....	329
428	GIN SANGAREE.....	329

<u>SLINGS</u>		
429	GIN SLING.....	329
430	SINGAPORE A, B.....	329

<u>SMASHES</u>		
431	BRANDY SMASHES.....	330

<u>SOURS</u>		
432	ASBACH SOUR.....	330
433	BRANDY SOUR.....	330
434	GIN SOUR.....	330
435	GUILLOME.....	330
436	RUM SOUR.....	330
437	SCOTCH SOUR.....	331
438	VODKA SOUR.....	331

<u>SWIZZLES</u>		
439	GIN SWIZZLE.....	331
440	TANGO COCKTAIL.....	331
441	TAKE TWO.....	331
442	TEQUILA SUNRISE A, B, C.....	331
443	TEXAS.....	332
444	THE DIRTY HARRY.....	332
445	THE HARRIKIRI.....	332
446	TULIP.....	332

<u>TODDIES</u>		
447	BRANDY TODDIE.....	332
448	BRANDY TODDIE.....	332

<u>TROPICAL COCKTAILS</u>		
<u>EXOTIC DRINKS</u>		
449	BANANA DAIQUIRI.....	332
450	BETWEEN THE SHEETS.....	332
451	BLUE HAWAII A, B, C.....	332-333



## Ön Söz

Şüphesiz basılmış olan birçok cocktail kitabı var. Bunların büyük bir çoğunluğu da bu kitaptan daha kapsamlı. Ancak bir bardaki tüm masalara birer tane koyamayacağınız o kitaplar, bir barmenin kurulama bezi kadar da ona yakın olamaz. Bu kitabı hazırlarken özellikle batılıların klasik & fantezi tüm cocktail'lerini içermesini, aynı zamanda da kolayca ulaşılabilecek bir kaynak kitap olmasını amaçladık. Bunların dışında belli düzeyde bir bar & cocktail kültürünü de vermek istedik.

İçkinin tarihi, insanlık tarihi kadar eski. Belli dönemlerde, belli toplumlarda yasaklanmasına (**prohibition**) karşın varlığını sürdürmüştü. Günümüzde de çoğunluğun vazgeçemediği bir olgu olarak etkinliğini devam ettiriyor. Madem ki vazgeçilemiyor & madem ki toplumda kendisini kabul ettirmiş, o halde turizm ruhuyla & bilinçli yapılsın. Bilinçli yapılan herşey gibi yarar sağlasın. Ne zaman, neyin, ne kadar içileceği bilinsin. Özetle dengede kalınabilsin. Zaten mutluluk da bu değil mi?

Herşeyde dengede kalabilmek. Bu kitaptaki cocktail formüllerinin bir bölümü daha önce yazılmış olan konuyla ilgili kitaplardan alınma. Bir bölümü ise-az da olsa-bizim eserimiz. Yani, bu kitabın yazarlarınının, Barantico Bar'ın bar ruhunu oluşturabilen barmenlerinin orijinal eserleri. Bu nedenle de meydana getirilen, salt bir derleme değil, belli düzeyde bir orijinaliteye de sahip.

Barmaid'lik, Barmenlik...(Barkeeping) Bir meslek değil bir yaşam biçimidir. Birçok alkollü & alkolsüz içkiyi shaker'da çalkalayıp, müşteriye sunmak mı barmenlik?

O zaman, domates suyu (salçası) ile Bloody Mary hazırlayan, ya da menekşe rengi (violet / veilchen) kadehte kırmızı şarap sunup içine bir parça buz atan da barmen. Değil... Barmen müşteri ile organik bir bağ kurabilendir. Müşterisinin kapasitesini bilen & dozu ona göre ayarlayabilendir. Kısaca barmen, mixolog & gastronom'dur. O, içkiyi hazırlarken, bir şiir söyler gibi, bir senfoniye çalar gibi, ya da bir baleyi icra eder gibi olmalıdır. Barmen; bir barda peynir eşliğinde rakı (*aslan sütü / lion's milk / löwen milch*) içenleri gördüğünde, Yandan çarklı Ada Vapurunda (*Dilenci vapuru – Bettler Schiff – Steem vapour – steamship (steamer that stops at every port of call) – Dampfschiff – mendiant vapeur*) çilingir sofrasını kurup Papazın Düzünü (*Priest's Straight Rakı, Rakı that does not contain any aniseed*) içen Neyzen Tevfik'lerin, Ahmet Rasim'lerin ya da ayakçı meyhanesinde (*Local Pub / kneipe / joint / dive*) yumruğunu meze (*Entrée-Hors-d'œuvre / kaltespeisen / soğuklar*) yapanların, kemiklerinin sızlayacağını düşünendir.

Yararlı olması dileği ile saygılarımızı sunarız.

*Adnan Mert*

## Foreword

Of course there are a lot of cocktail books, the majority of which are more comprehensive than this book, but those books, which you cannot put on each table in a bar & which cannot even be as close to a barman as his drying cloth. While preparing this book, our aim was that it should both include all the western classical & fantastic cocktails & also be a source book easy to handle. Furthermore, we wanted to give you bar & cocktail culture at the same time.

The history of alcoholic liqueur goes as far back as the history of mankind. In spite of the fact that it has been prohibited (**prohibition**) in certain societies at certain times, it has maintained its existence. (Today it is sustaining its influence as a fact without which the majority cannot do.) & now that it cannot be given up & that it has been accepted by society, let it be done conscientiously & suitably to the essence of tourism & let it be useful as is everything done conscientiously. Let it also be learnt when, what & how much to drink. Briefly, let everything be balanced. As a matter of fact, isn't that what happiness, what is all about?

To be able to balance everything? Some of the cocktail formulas in this book were taken from books previously written. A part of it, though only a little, is our work. In other words, it is the specially prepared work of the writers of this book who are the barmen who create the bar essence of the Barantico Bars. For this reason, what has been produced not only is a collection but has an originality of its own.

Barkeeping...(Barmaid , Barman) is not a job but a way of life.

Is barkeeping to shake a lot of alcoholic & alcohol free drinks in a shaker & serve the drinker? If so, anyone who prepares a Bloody Mary with tomato paste or serves red wine with ice in a violet (menekşe / veilchen) coloured glass is a barman, too. No! A barman is someone who can form an organic connection with his drinker. He knows his customer's capacity & can adjust the dose. Briefly, a barman is a mixolog & gastronomer. A real barman should feel, when preparing a drink, as if he is reading a poem, conducting a symphony or performing a ballet.

He is one who, upon realizing people sipping their raki (*aslan sütü / lion's milk / löwen milch*) eating cheese at a bar, can conclude how disturbed the bones of Neyzen Tevfik & Ahmet Rasim would be as, seated at their ironmonger's table on board the Princess Island paddle steamer – The Beggar's Ship (*Dilenci vapuru – Bettler Schiff – Steem vapour – steamship (steamer that stops at every port of call) – Dampfschiff – mendiant vapeur*) – on çilingir sofrası (*orientable*) they drank their Papazın Düzü (*Priest's Straight Raki, Raki that does not contain any aniseed*) & how disturbed the bones of those would be who used to start at the meze's (*Entrée-Hors-d'œuvre / kaltespeisen / soğuklar*) in assersby ayakçı meyhane(s) (*Local Pub / kneipe / joint / dive*)

Wishing this foreword to be useful, we offer our respect.

*Adnan Mert*



## Vorwort

Sicherlich gibt es viele gedruckte Cocktailbücher. Die große Mehrheit davon beinhaltet mehr als dieses Buch. Diese Bücher können nicht auf jedem Tisch liegen, aber Sie sollten beim Barkeeper sein, wie das trockene Tuch.

Bei der Vorbereitung dieses Buches, haben wir besonders darauf geachtet, daß es ein leicht erreichbares Quellenbuch wird & alle klassischen & phantastischen Cocktails der Westlichen Welt beinhaltet. Außerdem wollten wir sie mit einer bestimmten Bar & Cocktailkultur bekanntmachen.

Die Geschichte des alkoholischen Getränkes ist genauso alt wie die Geschichte der Menschheit. Obwohl es in einigen Zeitabschnitten & in bestimmten Gesellschaften verboten (**prohibition**) wurde, konnte es seine Gegenwart fortsetzen. Auch heute setzt es seine Tätigkeit fort als ein unverzichtbares Ereignis. Wenn es schon von der Gesellschaft akzeptiert worden & unverzichtbar ist, sollte es auch bewußt & mit Tourismusegeist gemacht werden. Wie alle Dinge, die bewußt gemacht werden, soll auch dies nützlich sein. Man sollte wissen, wovon man wann & wieviel trinken darf. Kurz gesagt, man sollte im Gleichgewicht bleiben. Ist das denn nicht auch das Glück in allem sein Gleichgewicht bewahren? In diesem Buch wurde ein Teil der Cocktailformeln aus Büchern entnommen, die vorher über dieses Thema geschrieben worden sind & ein Teil, auch wenn wenig, ist unser eigenes Werk. Das heißt, es ist das originale Werk der Autoren dieses Buches & zwar des Barkeepers der Barantico Bar, die seinen Geist bilden. Aus diesem Grund besitzt auch das, was hier geschaffen wurde, eine bestimmte Originalität & ist nicht nur eine bloße Zusammenfassung.

Barkeeping...(Barmaid, Barman) ist kein Beruf aber ein Lebensart.

Ist Barkeeping, mehrere alkoholische & nichtalkoholische Getränke in einem Shaker mixen & dem Gast anbieten? Dann ist der Barkeeper auch derjenige, der mit Tomatensaft (mark) Bloody Mary vorbereitet oder Rotwein in einem Veilchenfarbigem (violet / menekşe) Glas anbietet & ein Stück Eis reinwirft. Nein ist er nicht. Ein Barkeeper ist Jemand, der eine organische (*seelische*) Verbindung zwischen sich & dem Gast bilden kann. Jemand, der die Kapazität seines Gastes kennt & danach die Dosierung machen kann.

Kurzgefaßt, ein Barkeeper ist ein Mixolog & Gastronom. Beim Vorbereiten eines Getränkes muß er in der Lage sein, als würde er ein Gedicht aufsagen, eine Symphonie spielen, oder ein Balletstück vorführen.

Ein Barman ist; derjenige, der in einer Bar Leute sieht, die Rakı (*aslan sütü / lion's milk / Löwenmilch*) daneben türkischen Schafskäse essen saufen, wie in Yandan Çarklı Ada Vapuru, (*Dilenci vapuru – Bettler Schiff – Steem vapour – steamship (steamer that stops at every port of call) – Dampfschiff – mendiant vapeur*) wie in den romantischen Zeiten verliebte in ayakçı meyhane (si) (*Meyhane / Local Pub / Kneipe / joint / dive*) am Çilingir Sofrası (*Kneipentisch – Orientische Tisch – Orientable*) anstelle Meze (*kalt Speisen*) den Faustleckten Papazın Düzü (*Priest's Straight Rakı, Rakı that does not contain any aniseed*) denkt.

Wir hoffen das es Ihnen behilflich ist. Mit den Besten Wünschen.

*Adnan Mert*



**565 cocktails with recipe** “rezepte / reçete / recette” bar yönetimi, yiyecek & içecek servisi, getränkekunde, barbuch, servierkunde, service & cocktail guide, eiscremekunde, appetizers, beverages & cooking techniques, peçete katlama / napkin to fold, napkin folden, to plait, to ruffle / servietten falten, table / tafel, tisch / masa, sofras - form - glasses / gläser / bardaklar - form , menu cover - form, menu gedeckt deckel / kuver - form, International kitchen / küche / mutfak - lexicon, bar plans.

## **Türkiye'nin Julio Iglesias'ı, İlhan İrem.**

İstanbul'un gürültüsünden, keşmekeşinden, sanat dünyasının yozluklarından bunaldıkça, ayda bir , 15 günde bir de olsa hafta sonları Bursa'ya kaçıp geliyorum...

Yeşil şehrim & çocukluğumun güzel insanları birkaç güncük de olsa bir koza gibi sarıp sarmalıyor beni, & rahatlamış düşüncelerle yeniden tutuyorum istanbul'un yollarını...

Ancak Bursa'da son birkaç aydan beri keşfettiğim bir yer varki , müthiş! dost sevecen bir atmosfer içinde, olağanüstü güzel içkilerle doyumsuz akşamüstüler yaşıyorum orada...

Piccolo ya da Gastronomy burası bana yaşam sevinci veriyor...

Piccolo'da genç, girişimci çağdaş beyinler, romantizm'den uzaklaşmadan uzay çağına kozmik bir kapı açmışlar...

İlhan İrem - Şarkıcı / Bestekar / Müzisyen

## **İlhan İrem, Julio Iglesias of Turkey.**

Once or twice a month I come back to Bursa to escape the noise & confusion of İstanbul & be free of the monotony of the outside world.

My green city & the people of my childhood enfold me like silk & even after a few days I return to İstanbul with fresh thoughts. In the last few months, I have discovered a wonderful place in Bursa.

There, I have spent wonderful & pleasant evenings in a friendly atmosphere.

Piccolo fills me with the joys of life . the young , enterprising & contemporary brains behind Piccolo have opened a cosmic door to the space age of romanticism.

İlhan İrem - Singer / Musician / Musiker / Songwriter



## 500 Yıllık, Tarihi Yahudilik - Arapşükrü Sokağı

Judaism / Judentum / Yahudilik, Bursa'nın Kumkapı'sı

Antik Prusia / Bursa'dan – Tophaneden bakıldığında, Arapşükrü sokağı Bursa'nın altıparmak caddesinin bir üst paralelindeki, maket maket, pastel pastel badana boyalı, ahşap, kırma çatılı, s.m.ö evleri ile Yahudilik olarak bilinen bölgede yer alan balık lokantaları, barları, dance barları, café'leri, butik otel'i ile işkembe çorba-paçacıları, fast food'lar, Roman sokak müzisyenlerinin müziği eşliğinde, sazlı sözlü eğlence yerlerinin bir arada bulunduğu, taşıt trafiğine kapalı turistik sokaktır.

1990'den bu yana, turizm amaçlı özel yeme-içme tesisleri için bir eğlence sokağı olarak düzenlenmiş & "Bursa'nın nevizadesi" haline gelmiştir.

T.C. Kültür & Turizm Bakanlığı ruhsatlı, turizm işletme belgeli ( özel tesis )

ilk tesislerde kosova kökenli 3. jenerasyon / generation Mert ailesinin açmış oldukları tesislerdir. bu tesisler diğerlerine sebep-i esin olmuştur.

"Piccolo & Barantico" Mert ailesi halen, 14 yıldan bu yana Bursa – Tüyap fuar merkezinde, Barantico Restaurant'larını & café'lerini başarıyla işletmiştir.

Resmi adı Sakarya caddesi olan Arapşükrü sokağı bu adını Bursa'da bir meyhane kültürü oluşmasına katkıda bulunan, 1960' da hayatını kaybeden iş adamı "arap / araber /arabian Şükrü Değişmez" ( 1893 - 1960 ) den alır. Şükrü Değişmez, Arap lakabını dedesinin Yemen'de bir Arap kızı ile evlenmesi nedeniyle almıştır. 1893 Vodina ( Selanik yakını ) doğumlu Şükrü Değişmez( Arapşükrü ), askeri okulda okuyup subay olduktan sonra ( Akıncı Şükrü ) olarak Kurtuluş Savaşı'na katılmış, Kütahya yakınlarında esir düşmüş bir savaş gazisidir. Esareten kaçarken kolundan yaralanan & malulen emekli olan Arap Şükrü, ilk lokantasını

Ayvalık'ta açmıştı. daha sonra ilk eşi Servinaz Hanım & 2 küçük kızı ile Bursa'ya gelen Arap Şükrü, bugünkü Tayyare Kültür Merkezi'nin ( T.K.M ) yerinde bulunan Şark Kulübü'nün işletmeciliğini yapmıştır.

Ardından Yahudi kökenlilerin işlettiği meyhanelerin bulunduğu Yahudilik çarşısı (bugünkü Arapşükrü sokağı)'nda dükkân kiralayan Arap Şükrü, meyhanesinde müşterilerine kurufasulye, pilav, paça, işkembe çorbası türünde yemekler sunmuştu. Giderek ünlenen bu lokantaya Bursa civarından atlarla müşteriler gelmekteydi. İleride 5 erkek çocuğunun da işi sürdürmesi sonucu Arapşükrü, bir marka haline geldi & eskiden beri meyhaneler sokağı olan sokak Arapşükrü sokağı olarak ünlendi. Arap Şükrü'nün çocukları, damatları & torunları tarafından işletilen Arapşükrü balık restaurantları olarak hizmet vermeye devam etmektedirler. (Torunlarından Arapşükrü'nün oğlu Yılmaz dan olan çocukları Kıvanç & Bülent Değişmez ) halen Misi Köyünde (Mysia – Nilüfer) Arapşükrü - balıklı bahçe restaurant 'ını işletmektedirler! Bursa'da yaşayan 50-60 hanelik Yahudi nüfusun kullanımına açık olan Gerush Synagoge, Arapşükrü sokağında yer alır. Sokak, Zafer Plaza'dan Altıparmak'a doğru gelirken solda görülen ünlü balıkçı Reşat Kayapalioğlu ( balıkların kralı ) balık market & restaurant'larıyla başlar.

1990 yılında da Almanya'dan turizm okulu eğitilmiş, Kosova kökenli 3. jenerasyon / generation Mert Ailesi'de gelecek aile şirketlerine bağlı ( Piccolo Tourism Ltd. Co. / Barantico Tourism Ltd.

Co.) turizm ruhuyla

açtıkları restaurant, bar ( pub – café ) & dancebar ile kaliteli işletmecilik ruhuyla, start yaparak markalaşmışlardır. Romantizm'den uzaklaşmadan uzay çağına kozmik bir kapı açarak, yeni bir dönem başlatmışlardır. Arapşükrü - Yahudilik sokağında ihya olmuştur. Gençliğinde çekim merkezi olmuştur. Bu arada 500 yıllık tarihi Arapşükrü -Yahudilik sokağına çok önem veren, önünü açan dönemin osmangazi belediye başkanı sn. Erhan Keleşoğlu'na saygılarımızı sunuyoruz. Arapşükrü-Yahudilik sokağını seven ziyaret eden ziyaretçilerinde saygı & sevgilerimizi sunuyoruz. bu arada 500 yıllık tarihi Yahudilik sokağının restaurant işletmecisi dönemin Yahudi kökenli Sn. Vitali'yi anmadan geçmeyelim (Vitali restaurant'ın yeri şimdiki 16 no.'lu Piccolo / Eski fırın'ın duvar komşusuydu, Sn. Vitali sonra İsrail'e göç etmiştir.)

Sokakta yere her 5 m. de bir üzerlerinde Bursalı ünlü sanatçıların adlarının yazılı olduğu plakalar yerleştirilmiştir. şimdiki dönem Bursa'nın sn. üst düzey yöneticileri, Sn. Belediye başkanımız, sokağın hanlar bölgesindeki “Uzun-Çarşı” üzerine tarihi bozmadan yağmurdan korunma amaçlı yapmış olduğunuz çatı, hem ziyaretçiler için hemde çarşı esnafı için güzel oldu. Arapşükrü sokağının ziyaretçileri ile esnafı ise, yağmur yağdığında sefil-i rezil olmaktadırlar. Tarafgir olmadan bu sokağın esnafı & ziyaretçilerinin uzun-çarşı esnafı gibi hakları vardır. Bu nadide inci sokağa da önem verilirse nasıl olurdu.

500 yıllık tarihi Arapşükrü-Yahudilik sokağında bulunan gastronomy işletmelerinin, dünya'nın her yerinden gelen ziyaretçilerine turist değil misafir /guests olarak görmeleri, fiyatları normal menu fiyatlarında vermeleri turizm anlayışına en uygun hareket olacaktır. Arapşükrü sokağı / gastronomy bölgesinin, sokak sonuna kadar ruhsat verilip uzatılması (kırmızı çizginin kaldırılması), Bursa şehrine yakışan turizm anlayışının gerekliliğidir. Mixoloji & gastronomy dalında da böyle bir değerli tarihi sokağın turizme katkısı büyük olur.

Tescilli tarihi yapıların etrafındaki tescilsiz, problemlili kaçak yapılar (tarih kondular), sokağın tarihi ruhuna hiç yakışmıyor.

Atalarımız ne demiş “Söz uçar yazı kalır.”

Bursa'daki kumkapı , 8.Sultan/ 2. Bayezid ( 1481 – 1512 ) (engizisyon şeriat mahkemeleri Yahudi & müslümanları İspanya'dan atar (1492) ” ya zorla hristiyan olacaktardı, yani din değiştireceklerdi, yada terk edeceklerdi.”aslında 3 ilahi dinin de yolun sonu tek Allah'a gidiyordu. inandıkları tanrı aynı tanrıydı. ya hristiyan ol olmazsan öl yada terk et diyorlardı.

O dönemin sultanı Bayezid 2. büyük bir hoşgörü ile Yahudi ispanyolcası olan ladino dilini konuşan sefarad Yahudilerini İstanbul Ortaköy & Bursa'da Tophane altındaki Arapşükrü sokağı / Yahudilik'e yerleştirir. 1- the gerush synagoge (kovulmuş) 16. yy. / 2 - the Ets'ahayim synagoge / havra ( hayat ağacı ) 14. yy. 2. Sultan Orhangazi döneminde “1324-1362” synagog yapılmasına müsaade verilmiş olup yapının depremler & yangınlardan dolayı yalnız dış kapısı, üzerindeki yarım daire ferforge kısmı ile kadınlar bölümü ayakta kalmıştır .

3 - The Mayor Synagoge (Mallorca adasından gelenler '15.yy.)16. yy. başlarında 8.Sultan / 2. Bayezid (1481 – 1512) döneminde yapılmıştır. Tophane 'den kuş bakışı bakıldığında, beton yığını altıparmak caddesi'nin üst paralel'indeki, s.m.ö, maket maket, pastel pastel badana boyalı, ahşap, kırma çatılı, 5 yy.'lik tarihi sokağın bar'larında & balık lokantalarında, roman sokak müzisyenlerinin müziği eşliğinde bir akşam üstü macerası yaşayıp, balık yiyebilirsiniz. tavsiye edilir. Ama sıkı bir pazarlık yapmak kaydıyla.

Şimdiki dönem, Arapşükrü sokağındaki dükkanların % 65'i Reşat Kayapalioğlu 'nun, ( balıkçıların kral'ı) %25'i Türk-Musevi Vakfı'nın, %4'ü Turgay Güler'in,%6'sı Adnan Mert - Barantico'ya aittir.

Kabahat Turgay ile Adnan'ın annelerinde,doğduklarında anneleri isimlerini yanlış koymuş, ama Reşat'ın annesi Reşat'ın ismini “bilinçli” koymuş, altın doğuracağım demiş bebek doğduğunda ismini uzak görüşlü olduğundan bilinçli bir şekilde adını “Reşat” koymuş ( reşat altını ) şimdi bu sokakta en “bilinçli kuruluş” reşat – “deniz tabağı” balık - restaurant'larını göreceksiniz. 500 yıllık sokağın büyümlü atmosferinde akşam yemeği ( dinner ) yedikten sonra, dar bir çatal çıkmazı sokağından geçip ( Körfez'de / Zula'da ) gizemli ( Mysterious ) bir ön bahçeyi göreceksiniz ( arka bahçesinde var ! ) karşınızda 5 yy. 'lik s.m.ö., kırma çatılı, 2 bahçeli, 3 katlı yapının, her katında, aynı günde & aynı zamanda sabah saat 04.00 'e kadar ayrı ayrı maceralı atmosferi yaşayabilirsiniz.6 no'lu yapının yanında,8 no'lu yine 3 katlı, iç bahçeli 1 yapı daha vardır, burada pansiyon / pension /guesthouse / butikhotel – konaklama & 5 odası ile 2.5 m. x 2.5 m. 1000 yıllık tonoz var.

## 500 Years History of Arapşükrü Street

Judaism / Judentum / Yahudilik, Bursa's Kumkapı

Looking from the Tophane over an ancient city prusia/Bursa, Arapşükrü street is parallel to – altıparmak street, with whitewash, pastel-painted wooden maquette, with crushing roofs, p. m. d. homes are situated in the area known as judaism fish restaurants, bars, dance bars, café, boutique hotels, the tripe soup-paçacıları, fast food, street performers, accompanied by music, novel as rescuers reach remote areas a verbal entertainment locations, vehicle parking is forbidden in this tourist street.

since the 1990 's, district has been organized as an entertainment street” Bursa's nevizadesi” a private foods & beverage facilities all that for tourism purposes.they are all with ministry of culture & tourism ministry licensed, with a tourism business certificate (private property) one of the first restaurants were opened by the 3.rd generation of Kosovian family. These facilities have been good reason to be inspired by others.

“Piccolo & Barantico” run by the Mert family, last 14 years they run catering business at Tüyap fuar in Bursa as well , their Barantico restaurant & café-bars run successfully.

The official name of the Sakarya Street ( Arapşükrü street ) is a pub culture gets his name from the men who died in the 1960 the business man called “arab / araber / arabian sukru degismez” (1893-1960). his grandfather was married to a Yemeies lady hence the name is ‘Arab’ comes from. Şükrü Değişmez was born in 1893 town called vodina (near Thesaloniki), he went to military school he became a tough officer during participating in the war of liberation (Akıncı şükrü) he was woun-

ded & captured, he is a Kütahyas' war veteran. After his release has retired from army & opened his first restaurant in ayvalık. then he & his first wife servinaz hanım & their 2 little girls come to Bursa & run orient clun opposite Teyyare Culture Center / Tayyare Kültür Merkezi, (T.K.M).

Later on he opened a restaurant (meyhane) with specialities foods to cutomers were beans, rice, trotting, the tripe soup type dishes. this restaurant is became very famous for its customers.

As a result of his success with his 5 boys has become a brand/ marka name in the Arapşükrü street, the street used to be called ' pubs street 'operated by the descendants of the children of the Arapşükrü damatları & Arapşükrü fish restaurants continue to serve as. (the son of Arapşükrü children with pride from the decisions & bülent yılmaz) now they run place called Arapşükrü-fish garden restaurant at called missi village (mysia).

Bursa's jewish population of 50-60 habitants that uses gerush synagoge / havra is located in the Arapşükrü street. street from the zafer plaza to altıparmak (as seen on the left) starts with famous fish market & restaurants owned by the reşat kayapalıoğlu. (king of fishermen)

in 1990, also from germany, the tourism school educated 3. generation of Mert family with a tourism spirit in mined opened a restaurant called (Piccolo tourism Ltd. Co. / Barantico tourism Ltd. Co.) bar (pub – café) a quality business, with dancebar & became a well known brand name. he started a romance without navigating away from the space age by opening the door to a new era of cosmic with determination. Arapşükrü - Judaism Street / Arapşükrü Sokağı - Yahudilik did satisfied every generation that includes the young. meantime, in the 500-year history Arapşükrü-paving the way for that period to care so much about judaism street we salute the mayor of osmangazi mr. erhan keleşoğlu.

we must thank all the visitors of Arapşükrü- judaism street. in the meantime, we must offer our thanks & respects to mr vitali in 500-year history of jewish origin of judaism to the alley restaurant operator in the Arapşükrü street.

(restaurant was next door to number 16 's Piccolo/old oven's wall area. Mr. Vitali then emigrated to Israel.)

Also on the ground on the street every 5 m. is a famous artists ' names written on ginsberg plates. current period of Bursas' senior executives, & Mr. Mayor, has helped to put these spectacular roof & rain cover on main market / hanlar bölgesi.

Uzun - Çarşı in the centre of Bursa. Thank you. But Arapşükrü street visitors & I with shopkeepers are miserable when it rains.

The towards end of 15th century the Spanish courts gave choice to those Moslems & Jewish people who used to live in Spain either become a Christian or to leave Spain, The Ottoman 8. Sultan Bayezid 2. offered those jewish people to settle in Bursa & Ortaköy in istanbul, and those settled in Bursa, the Sultan build them a 3 Synagoges . (1-the gerush synagoge, 2-the etsahayim synagoge, 3-mayors synagoge ) like the western mentality without keeping a political side, owners of those restaurants & its customers expects a same type of favour like those given to cities open market, if in this 500-year history Arapşükrü-judaism street shelteres from the rain believe me your



popularity will increase more. registered historical buildings surrounded by illegal unregistered buildings does not look good at all, the west of the streets entry key is in the hands of the turkish jewish foundation and bath owner, the eastern entrance is in the hands of the fisherman resat & florist this is not fair.

what our ancestors might have said “flies article.” ı asked the govener ‘ please find a solution to this unfair competition ‘.

currently, 65% Arapşükrü street shops/restaurants owned by reşat kayapalıođlu ‘ (then king of fishermen) 25% of the turkish-jewish foundation,4% of turgay güler ‘s, 6% of adnan Mert ‘s.

You’ll see & feel the magical atmosphere of the 500 years old street, after eating your dinner, if you take a walk through you come a cross a narrow dead end small road you will see a mysterious garden introducing the 5th century. s.m.ö., a 3-storey building with garden, on the same day at the same time, in each floor you can experience the atmosphere up to the morning hours 04.00 am , next to the three-storey building there is a pension / guesthouse / butikhotel. 1000 years old meditation room( 2.5mx2.5m).





Fidel Alejandro Castro (1926 - 2016) “yaş 90”



Comandante Dr. Ernesto Ché Guevara (1928 -1967) “yaş 39”

Yıl, 16.yy. genç bir kaptan 8. Sultan Bayezid 2.nin (1481-1512) 2 defa ayaklarına kapanıp baş vurur “Sultanım bana gemiler verip yardımcı olunuz size yeni bir dünya keşfedeceğim” der, Sultan genç & Çılgın Kaptan’a bakar bakar kaptanı yanıtız olarak geri gönderir, kaptan İspanya Kraliçesi Queen İsabell’e gidip kraliçeyi yeni dünya keşfetmesi konusunda ikna eder, kraliçenin aklına yatar, bu genç kaptana gemiler, para & mühüm mat yardımcı yapınız der.

Sonucunda genç kaptanın **Queen İsabell Apose**’den isteği geri çevrilmiyor. Bu genç kaptan **Christopher Columbus**’tur & Amerika’yı keşfeder (1492). “Christopher Columbus Cenova asıllı olduğundan İspanya kraliçesi adına yeni dünya “**Nuevo Mundo**” keşfine çıkmadan önce İspanyol vatandaşlığına geçmiştir, Americus Vespuccius (1454 – 1512) yılları arasında yaşayan & kuzey – güney Amerika kıtalarına adını veren İtalyan denizcidir.”

Bu arada İspanya’daki 8.yy.’da Endülüs / Andalusia başlayıp muhteşem bir elhamra “kırmızı” sarayı (1238-1368) yapıyor.baş şehirleri granada ‘nar’ arap & latin halklarının kombinasyonuyla müthiş bir flemenco karma kültürü doğuyor, tıpkı Makedonya kralı 2. Philippos oğlu Megas

Aleksandros 3. (M.Ö./B.C. 336-323) doğulularla batılları evlendirip sentezli Anatoliadaki Rum kültürünü oluşturdu.

Bu arada Endülüste aslında Musevi asıllı olan kendisini gizleyen Kral 1. Ferdinand (Ferdinando 1.) arkasına engizisyonu alarak Müslüman & Yahudileri zorlar,yahudi avına çıkar "Ya Hristiyan olun, ya ülkeyi terkedin, ya da ölü" der. Endülü'sün son Sultanı 2. Abdullah Osmanlı Sultan 2. Bayezid'den yardım ister, ama Osmanlı'nın en Romanex kadınların çok beğendiği şehzade cem Sultan "Tzm / Zizim" (Prusa'da 18 gün Sultanlığını ilan etti, adına hutbe okutup para bastırıldığından Sultan denmektedir), Avrupa'da Osmanlı'ya karşı diplomatik esir olarak kullanıldığından Osmanlı ordu yardımı gönderemez. Sultan Bayezid İspanya'ya Kemal Reis'i (Piri Reis'in amcası) & donanmasını İspanya'ya gönderdi, Kemal Reis Müslümanları Kuzey Afrika'ya, yahudilerin de üst düzey ailelerini Selanik'e, Konstantiniye / İstanbul'a Ortaköy ile Karayköy'e & Prusia / Prusa'daki 500 yıllık tarihi Yahudilik / Arapşükrü sokağına yerleştirdi. 150 bin Yahudi Osmanlı vatandaşı oldu. Endülüste yenik düşen son Sultan 2. Abdullah'da latinler ile savaşmadığından ağlamış annesinde " ağla ağla erkekler gibi savaşmadın, bari kadınlar gibi ağla " der. Prusa'daki 500 yıllık tarihi Yahudilik - Arapşükrü sokağında 1326 Prusanın Feth'inden sonra Ets'ahayim (Hayat Ağacı) Synagoge'u 2. Sultan Orhangazi döneminde "1324-1362" yapılmasına müsaade verilmiştir. Yapının depremler & yangınlardan dolayı yalnız dış kapısı & üzerindeki 1/2 daire kapı üstü aydınlık bölümüne ferforge (el işi demir) kısmı ile kadınlar bölümü ayakta kalmıştır.

Mayor Synagoge ise 15. yy. da İspanyanın Mallorca adasından Osmanlıya sığınan musevi göçmenlerce 10. Sultan Kanuni Sultan Süleyman oğlu 11. Sultan 2. Selim'in (1566-1574) dönemine kadar göçler sürmüştür. 2. Selim'den sonra Osmanlı tabiiyetine geçen Ladino İspanyolcası konuşan Sefarad Yahudileri'ne kadar aradan 450 yıl geçer.

Gerush (kovulmuş) Synagoge ise İspanya Andalusia / Endülüs Emeviye'den Engizisyon (şeriat) mahkemeleri tüm musevileri İspanyadan kovduklarından **Gerush** (kovulmuş) Synagoge adı verilmiştir.

19. yy. Osmanlı zor dönem yaşamaktaydı Ruslar'ın başında Çar 2. Nikolaus / Nicolai / Romanow ailesi balkanlarda Sırları & Bulgarları Osmanlıya karşı ayaklandırıp savaş ilan eder niyetleri dünyanın kalbi & merkezi Konstantineyi ele geçirmektir. Dünyanın kalbi Anatolianın kaskasları ele geçirerek araya Ermenistan'ı sıkıştırarak Türkler'in orta asya kara yolunu kesmektir, 1. Dünya harbi başlamıştır. Ama Küba'nın baş şehri Habana/Havana'da muhteşem bir yaşam vardı, İspanya'nın kolonisi olan Küba'da Amerikanın gözü vardır bu yüzden İspanya & Amerika arasında savaş tamtamları çalmaktaydı. İspanyada & Osmanlıdan dil problemi olmadığından aradan geçen 450 yıl sonra Osmanlı tebasındaki Sefarad Yahudilerinden torunlarının torularından **Francisco Ruz** isimli şahıs Konstantineye'den iç karışıklıklar sebebi ile geçici olarak Küba havanaya göç eder. Akli hep Konstantiyede & Prusia'dadır, geri dönme hayaliyle yaşarken Havana'da **Domingo** adlı Küba'lı kıza aşık olup evlenir & 3 kızı olur. kızlarına da hep geri dönme hayali olan Konstantiniye & Prusia'yı anlatır.

Bu 3 kızdan biri evlenip 1926 yılında ileride tarihe geçecek bir erkek bebek doğurur, o bebek kimdir ? Fidel Castro'dur. Bu arada Rusya'da büyük iç savaşı olan komünist Bolşevik Harekatı başlar. Çar 2. Nicolai Romanov "1612 yılında Rusya'nın iç karışıklığında Andrei Romanov adlı Rus köle efendisi İspanyol şovalyesi ölünce onun evraklarını alıp yerine geçen ilk çar

**oldu & böylece 300 yıl boyunca Romanov ailesi üst akılın kışkırtmalarıyla Türklerin başına bela oldu, Bolşeviklerin Romanov ailesini kurşuna dizmesiyle sonlandı.”** İngiltere kralı olan kardeşinden sığınma hakkı ister, tarih acımasızdır. Kardeşi yardımcı olmak istemediğinden Romanov ailesi Bolşeviklerle yakalanıp kurşuna dizilirler. Böylece Türkler birkaç cephede savaştığından Rusya cephesinden rahat bir nefes alırlar. Osmanlı'nın yetiştirdiği değerli komutanlardan Gazi Mustafa Kemal & arkadaşları, Anatolia halkı, efeler, zeybekler, patriotlar / yurtseverler, ufukların efendileri, cesur yürekler, serden Geçtiler / Dalkılıçlar, Çılgın Türkler Anadolu halkınıda arkasına alıp işgal halindeki vatanlarını 4 bir yandan kurtarmak üzere “**ya istiklal, ya ölüm**” diyerek büyük diriliş / bağımsızlık savaşını başlatırlar.

Bu arada 1920'lerde Amerika'da içki yasağı konulunca dönemin mafyaları All Capone'leri **Stinger** adı altında Bathup Gin adı ile bilinen & banyo küvetinde destile edilen, gerçekte ateş suyu gibi tadı olup içilemeyecek kadar bu sert içkiyi şişeleyip kaçak yollardan dünyaya satıp parayı bulurlar. Aynı zamanda Küba Havana'da lüks & görkemli bir hayat yaşıyorlardı. Amerika'dan gelen büyük yatırımcılar Havana'ya casinolar, gazinolar, oteller & eğlence yerleri / barlar inşa edip lüks bir yaşam biçimi yaşıyorlardı. Avrupa'da savaş varken, Küba'da lüks yaşam süren Osmanlı'nın Secret Service / Gizli Servis / şimdiki MİT ile Amerika'nın Scret service / Dians Intelligent Agency / şimdiki CIA'sı Küba'ya gitmişler & orada neler oluyor diye gözlem yapıyorlardı.

Aynı zamanda Küba'da **Bacardi** ailesi lüks bir hayat yaşıyordu, şeker kamışı tarlaları vardı. Şeker üretip dünyaya satarak parayı buluyorlar. ellerinde o kadar çok şeker kamışı mahsülü artıyorki, ne yapmamız gerekir diye araştırma içindeydiler. Sonradan bu kamışlardan ispirtolu içki sınıfından **rum** elde edip, şişeleyip **Bacardi Rum** adı altında dünyaya satarak daha çok zengin olurlar. İçinde swimming pool / yüzme havuzu olan lüks villada yaşıyorlardı. 2. Dünya savaşında Avrupada & Avrasya komşularında korkunç savaşlar yapıyor milyonlarca insanlar ölüyordu.

Küba'da genç Fidel Alejandro Castro büyümüş makine mühendisi olmuştur. Elinde evlenmemiş kızların dizlerinde rulo yapıp ten kokusunu alan meşhur Küba purosunu, başından çıkarmadığı **Castromodel** şapkasıyla, o dönemin Lüks Amerikan arabalarının reklamını yapmaktadır. (ileride hiç bozulmamış Küba'nın bu tarzı dünyanın turizm cennetine dönüşmesine esin kaynağı olacaktır!) Küba'nın başına da diktatör Fulgencio **Batista** vardır. Genç lider Castro “patriot / yurtsever, karizmatik”. Bolivia'dan motorsikletiyle Arjantinli Comandante Dr. Ernesto, **Ché Guevara** Küba'ya gelir. Sırtında bir çanta hep kitap okumaktadır. Çantasının içinde de son kitabı vardır. Ché hem karizmatik hem de yakışıklıdır, Uzun siyah saçlı, kadınların beğendiği Romaneks bir tiptir, başında her zaman yıldızlı beresi vardır. 2 lider karşılaşılır & aynı düşüncelerdedirler. Küba halkı bağımsızlık savaşında bu 2 kafadar liderin arkasındadır. Gerilla olarak Batista & ordusuna savaş ilan edip dağlara sığınır. Batista & ordusunu yenerler. Batista kaçır, kommünizm ilan edilip tüm kamu & özel mallara el konulduğunda, Amerikan yanlıları gemilerle Amerika'ya kaçarlar, yurtseverlerde Küba' da kalırlar. Amerika Küba'ya ambargo üstüne ambargo uygular. Küba yüzünden sscb ile Amerika arasında nükleer savaş neredeyse kapıdadır, bu dönem ½ asırlık olup günümüze kadar devam etmiştir. sular yeni yeni durulmaya başlamaktadır. “başkan **Richard Nixon & John F. Kennedy** dönemleri” Bacardi ailesi zirveden yere ögle bir çakılırlar ki 5 parasız kalırlar, bir ekmeğe dahi muhtaç olurlar. Onlarda Amerikaya gemiyle kaçarken ailenin küçük oğulları akıllı davranıp **Bacardi Rum**'un gizli reçetesini beraberinde götürür, bu gizli reçete ileride tekrar ayağa kalkmalarına sebep olacaktır.

Comandante Dr. Ernesto, Ché Guevara Fidel Alejandro Castro'ya "ben Boliviya'ya & Arjantin'e bağımsızlık savaşı başlatmak üzere gidiyorum" der. Castro "gitme senin yerin burası burada kal" der. Buna rağmen Ché motosikleti ile sırtında çantası, içinde de okuduğu son kitabı ile Boliviya'ya doğru yola çıkarken Amerikan secret service onu boliviaya yönetimine jurnallerler & Ché Guevara pusuya düşürülüp kurşun yağmuruna tutulur, kurşunlardan biri kalbine isabet edince ölüyor "tıpkı Bonnie & Clide gibi, tıpkı Maria Puzo'nun The God Father'deki Don Vito Corleone'nin oğlu Sonny Corleone'nin kurşun yağmuruna tutulduğu gibi. Sonunda geriye Che'nin bir motosikleti kalır, bir de çantası. Çantasından da okuduğu son kitabı çıkıyor ! Atatürk'ün nutuk kitabı. (Vito Corleone'nin kurduğu firma Genco Olive Oil Export / Genco zeytinyağı ticareti şirketidir.)

Bu arada Küba'da kısmi yerlerde & 18 yaş altı gençlerde içki yasağı vardır. 18 yaş altı Küba'lı gençler eğlence yerlerinde paso coca cola içmektedirler. halk da buna anlam veremeyip niye bize yaptırımlar yapan düşmanımız Amerika'nın ürünü olan Coca Cola'nın bu kadar çok içilmesine anlam veremezler, ama işin aslı böyle değildir, gençler uzun / long drink bardağına Coca Cola doldurup, içine de limon suyu & Rondella limon koyup, çantasından gizlice getirdikleri Bacardi Rum şişesini çıkarıp long drink bardağının içine doldururlar.

İşin aslı gençlerden biri iyice narkoz alıp, meftun olunca, dolu long drink bardağını alıp salonun ortasına çıkıp havaya kaldırır, halka doğru bağırarak **Küba Libre - Küba Libre** / Bağımsız Küba - Bağımsız Küba diye bağırınca, işin aslı anlaşılır. Coca Cola'lar toplanır, o genç tutuklanıp hapsi boylar, böylece Küba'nın bağımsızlığı şişenin içinden çıkıp, ünlü bir cocktail olup dünyaya yayılır.



## INDEPENDENCE OF CUBA / Küba'nın bağımsızlığı



Fidel Alejandro Castro (1926 - 2016) “age 90”



Comandante Dr. Ernesto Ché Guevara (1928 -1967) “Year 39”

Year, On the 16<sup>th</sup> century a young captain goes to 8. Sultan Bayezid 2<sup>nd</sup> (1481-1512) Twice to ask him if he can provide him ship & a money to discover the new world for him . The Sultan looks at the young & crazy captain & sends him without saying a single word.

Captain then goes to Spanish Queen Isabell & convince her to discover a new world & she orders to his men to give this young captain ships, money & ammunition. This young captain was Christopher Columbus (1492) originally he was Genoan before discover a new world he became Spanish.

Italian sailor called Americus Vesputius (who lived between 1454 – 1512) also gave his name to North & South American continent. Starting in the 13<sup>th</sup> century a spectacular Alhambra ‘red/kırmızı’ palace (1238-1368) was built in Spain. Arabic & Latin people of Granada has created a dance called flamenco ( it is a dance that reflects combination of a mixed cultures ) just as the Macedonian king Philips 2<sup>nd</sup>. & his son Megas Alexandros 3. encourages mix marriages between west & east cultures that of Anatolia & the East, like our origins as a Turk, no matter how happy you feel we are not Europeans, nor Asian, we are Eurasian, Eurasian.



One country, one nation, one flag, this is us we are proud nation & what a beautiful feeling who ever says " I am a TURK ". its color is beautiful isn't it ?

Mean while in Andalusia, Jewish descent who disguises himself as a King Dec Andalusia 1. Ferdinand, taking back the Inquisition, & forces Muslim & Jews people to choose by saying " you must either become Christian or leave the country or die," . The last Sultan of Andalusia Abdullah 2nd Asks for help from The Ottoman Sultan Bayezid the 2nd. But The Ottoman Empire can not send help because the Prince CEM Sultan "TZM / Zizim" was kept prisoner for the bargaining power against the Ottomans in Europe, Cem sultan was very nice looking Prince who was also loved by Romanex women.

Sultan Beyezid sends Kemal Reis (Uncle of Piri Reis) Admiral of the Ottoman Navy to Spain. Kemal Reis placed those Muslims & Jewish imigrants & their families to in Thessaloniki, Istanbul & Bursa ( 500 years ago some Jewish people were settled in a place called Arapşükrü ( Jewish region in Bursa). Than these 150.000 Jewish became Ottoman citizen.

During 19th century Ottoman Empire was having hard times. Russian Tsar 2. Nicole / Romanov family was in power. He provoke Serbs & Bulgarians in Balkan against the Ottomans, his intentions was to conquer Constantinople which is the heart & center of the World. He wanted to cut all Ottomans connections at the east of Anatolia & central of Asia. First World War had began. But there was a wonderful life in Cuba's capital Havana. Cuba was one of Spain's colony which America had eyes on it. Alarm war bells was ringing between Spain & USA. During the Balkan war, a man called Francisco Ruz from Constantinople ( because he didn't have any language problems ) went to Cuba ( Havana ). His mind was always in Constantinople, dreaming one day to go back to Constantinople . Domingo falls in love with local Cuban girl & marries her ,he has 3 daughters & he was always used to tells his daughters about Istanbul & his dreams about returning back there. One of the daughter gave birth to a boy in 1926, who was this boy??? This boy was Fidel Castro. Meanwhile, communist Bolshevik movement started in Russia.

Tsar 2. Nicholas Romanov (Nikolai) was seeking asylum from his brother King of England. But his brother did not help him. So Romanov family was killed by the Bolsheviks. Turks take a deep breath. Because of Mustafa Kemal & his friends brave actions created a great patriotism in Turkey. They were the brave hearts, they were the masters of horizons/ patriots of the master horizon, who were gone hard crazy , By taking the Anatolia people their sides They have started the independence movement to save the country from the enemy. When the government forbid the sale of alcohol in USA in 1920's the mafia in that period became very rich by selling a kind of alcohol under the name Stinger a kind of hard sipirit called Bathup Gin distilled in a bath tub in all over the World. Large investors from America went to Havana & built casinos, hotels & entertainment venues & lived a lavish lifestyle.

While the war rages on in Europe, life in Cuba was luxurious, Secret Service of Ottoman & USA went to Cuba for spying, Meanwhile Bacardi Family in Cuba was living a luxurius life. There had sugar cane plantations. They find the money by selling & producing sugar to all over the World. There was so much sugar cane in their hands. They are in research & from this spirituous beverage obtained from the class of the cane rum, & bottled & sold under the name baccardi Rum. Young leader Castro ( Patriotic , charismatic ) . taking the people behind as counter guerrilla, declared



war on Fulgencio Batista & his army, They seek refuge in the mountains. Argentinian Comandante Dr. Ernesto from Bolivia come to see Ché Guevara in Cuba. Always reading a books . Ché is both cool & handsome with long black hair & a type of romanex guy women likes. There is always star beret in his head. The two leaders meet & they have the same thoughts . Together they started a great independence war. They beat Batista & his army. Batista runs away & communism had declared & all public & private property was confiscated. Pro-Americans fled to America , all patriots stayed in Cuba.

America imposes an embargo on Cuba. Nuclear war between Russia & USA was almost started. (President Richard Nixon & John F. Kennedy period) Bacardi Family they fall to the ground from the top. They're become broke, they are even be in need of bread. When they were Fleeing to America , One little boy finds the secret formula of Bacardi Rum . This secret formula will help them to recover again. Argentinian Comandante Dr.Ernesto & Ché Guevara says to Fidel Alejandro "Castro I will go to Bolivia & Arjantina to start independence war there. Castro says dont go your place is here & stay here ". Ché In spite of this cry, jumps his motorcycle with his bag on his back with books . When he was going towards Bolivia ,American Secret Service reports him to Bolivian authorities then Ché Guevara ambushed & held in a hail of bullets just like Bonnie & Clide or like Sonny Carleone son of Don Carleune in the movie The God Father of Maria Puzo.

There was a book Inside of his bag a book that he was reading called " Ataturk's Speech ". Meanwhile some parts of Cuba alcohol was prohibited for under 18. So young Cuban under the age started to drink Coca Cola. The people could not understand why American made drink becomes so much popular who the enemy of Cuba ,the product of Coca Cola-not meaning to be, but the truth is not like that, young people long to fill up a long drink glass & lemon juice in Coca Cola & Bacardi lemon put rondell & secretly brought out of the bag the inside of the bottle of rum they fill a long drink glass. Actually one of the boys after he got drunk from that drink goes into the middle of the room & shouts towards the people Cuba Libre, Cuba Libre, Free Cuba, Free Cuba than they .Coca Colas are collected & young boy was arrested & sent to jail. So that Cuba's freedom goes out from the bottle to become a well known cocktail & spread out all around the World.



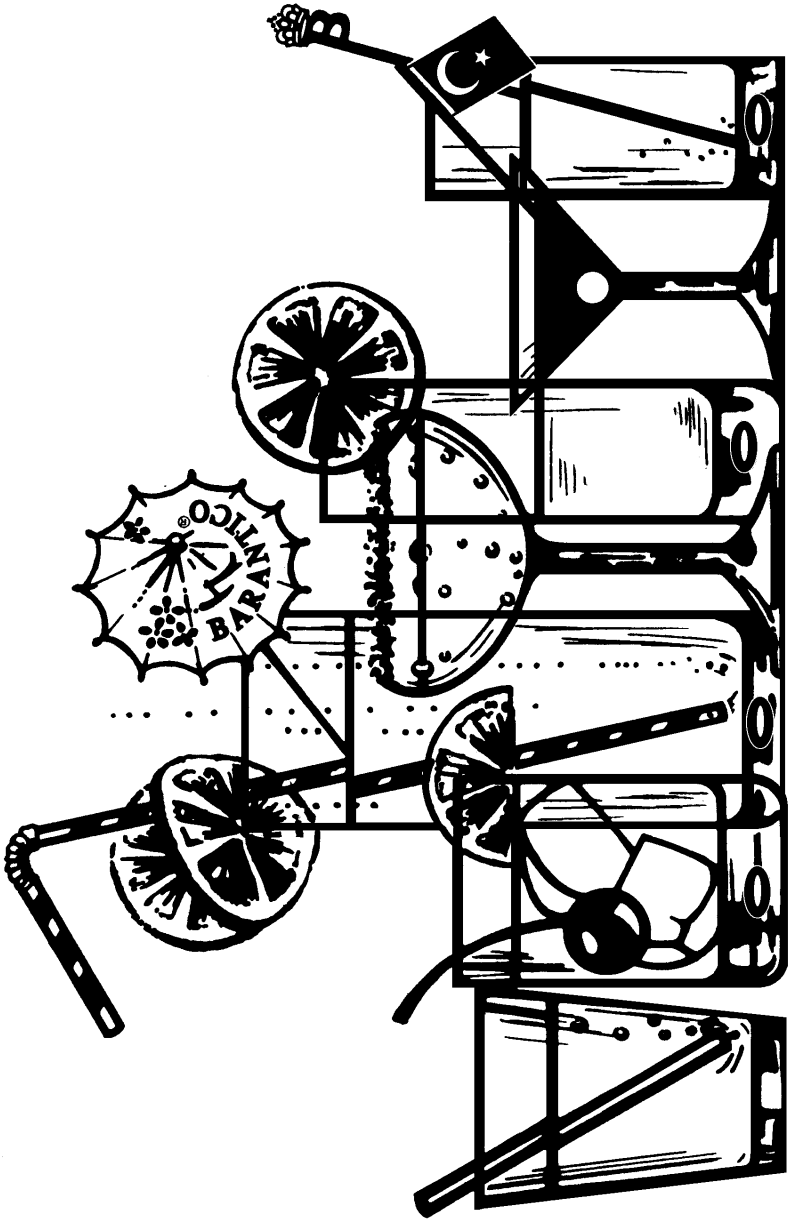

## ◆ YİYECEK İÇECEK SERVİSİ & METODLARI

### Fransız Servisi /Service à la Française

Fransız servisinde eski Fransız **Service en ambigu** & yeni Fransız Service à la Française metodları arasındaki farklılıklar dikkate alınmalıdır. Eski Fransız servisi temelde sadece tarihi öneme haizdir. Fakat Danimarka servis usulünde **Anretning /Entrée** (*erster Gang nach der Suppe – çorbadan sonraki ilk giriş/servis – first course/ deuxième service – secondo piatto – segundo plato*) /**Zwischengericht/ Ara yemek** de kullanıldığı için burada belirtilmesi gerekir.

Yemekler 2 bölümde sofraya konur. 1. bölümde: **Hors-d'œuvres** (*Vorspeisen/Entremeses*), çorba sıcak ara yemekleri, esas yemek (*main course – Hauptgericht – plat principal*) & kızartma sunulur, daha sonra 2. bölümde: Soğuk et yemekleri, soğuk ara yemekleri & çörekler, tüm küçük hamur işleri & **pâtisserie** (*Tatlılar/Süßspeisen/ Nachtische/Nachspeisen/Entremets/tatlılar/soğuklar/desserts/sweets*) takibeder.

Bu eski Fransız usulünde sıcak yemekler aynı anda sofraya getirildiğinden sıcaklıklarını koruyabilmeleri için *rechaud* (*reşo/ısıtıcı*)'da tutulmaları gerekliliği yiyeceklerin lezzetini kaybetmesine sebep oluyordu.

Birkaç kaptan oluşan modern Fransız servisinde yemekler parçalanmadan servis yapılır & müşterinin gözleri önünde *Trancheur* (*tranşör/kesici*) tarafından parçalanarak müşteriye sunulur. **Hors-d'œuvres /Vorspeisen/Entremeses/Zwischengericht/ entrée/entrance/ara yemek, ara yemekleri & soğuklar Hors-d'œuvres /Antipasti/ Vorspeisen/Entremeses/Zwischengericht/ara yemek** gibi yiyecekler bir büfenin uç kısmında bulundurulur. Değerli kuver (*Gedeck/cutlery/besteck/couvert/cover/çatal, kaşık, bıçak, ç.k.b.*) takımların ağız kısımlarının ters gelecek şekilde sofraya konması, Fransız servisinin bir özelliğidir.

### İngiliz servisi /service à la Anglaise/yuvarlak servis

Rus servisinin aksine İngiliz servisinde büyük yemekler parçalanmadan bütün hazırlanır, yiyecekler, takdiminden sonra sofrada veya *guéridon* (*tivoli/servicable/servant*) üstünde *Trancheur* (*tranşör/kesici*) veya *Chef de Rang* (*waiter/ kellner/garson*) tarafından parçalanır & tabaklara dağıtılır. Yardımcı garsonlar yemeklerin bulunduğu tabakları tek tek müşterilere sunarlar. Çorbalar, çorba kaselelerinde servis yapılır & müşterinin gözleri önünde, ilave masada tabaklara boşaltılır & sofraya yerleştirilir.

Kesip ayırım işi ya ısıtıcı arabada veya ilave masada yapılır. Bunun için yiyecekler ilave masada *Trancheur*'ün önünde & tabaklar yiyecek tepsilerinin sağında bulunur. Yiyecekler *rechaud* (*ısıtıcı/reşo*)'da servis için sıcak tutulurlar, ancak tabaklarla birlikte alınırlar. Aynı zamanda birkaç yiyecek sunulacaksa, kesme (*tranche/schnitte/ slice/trancia*) birkaç garson tarafından yapılır. Son esas yemeğin servisinden sonra henüz gerekli olan takım hariç herşey toplanır. Sofranın düzenlenmesinde esas itibariyle 3 *cutlery* (*besteck/couvert/kuver/çatal, kaşık, bıçak*) takımdan daha fazla *cutlery* (*besteck/couvert/kuver çatal, kaşık, bıçak, ç.k.b.*) takım parçaları yerleştirilir. *Menaj/ cruet-stand/ménagèrel tuz, biber* & baharatlı soslar sofrada ilk baştan yer almışlardır. İngiltere & Amerika'da ilave tabaklar çatalların üst tarafında bulunurlar, bunun üst

tarafında tereyağı bıçakları masa kenarına paralel olarak durur. İngiliz servisi en kibar hizmet şeklidir. Kaynağını İngiliz ailesinin adetlerinden alır. Özel servis çalışmaları yanında; müşteri masasında yemeklerin parçalanmasını, balıkların ayıklanmasını, alevlenmesini & pişirip hazırlanmasını da kapsamaktadır. Bu servis metodu 8-10 kişilik masalarda en güzel şekli ile uygulanabilir. Servis personelinin eşli çalışması gerekir & ilave masayı müşterilere doğru çevirmek zorundadır. İngiliz servisi nispeten çok zaman aldığı için tercihen akşam servisinde uygulanır.

### Rus servisi /service à la Russe

Bu serviste çorba tek başına tabaklara konur, büyük parçalar mutfakta parçalanıp ayrılır, tekrar birleştirilir, tepsilere konur & itinayla garnitürlenir (*Beilage*). Tepsilere servis personeli tarafından elden ele dolaştırılarak sunulur. Soğuk Hors-d'œuvres, salatalar kompostolar, ilaveler & soğuklar sofraya konabilir. Ancak rus âdetine göre eskiden yiyecekler servanterler (*guéridon/tivoli/service table*), üzerinden sofraya servis yapılırdı.

### Amerikan servisi/service Americain

Bu serviste **Hors-d'œuvres** (*Hors-d'œuvre/Antipasti/Entremeses/ Vorspeisen*), ara yemek (*zwischengerichtelantretning/Entrée*) & esas yemekler, (*main course/Hauptgerichte/platprincipal/piattoforte/plato fuerte*) soğuk yemek & tatlılar "*pâtisserie (desserts/süßspeisen/Nachtische/Nachspeisen/entremets/swets / soğuklar "soğukluk")*" tabaklarda servis yapılır. Bu metod sayesinde servis çalışmaları rasyonelleştirilebilir. Amerikan serviste garnitürler (*Beilage*) direkt sofraya konabilir.

### Baküs-Fondü / Bacchus – Fondue

Dana eti ince parçalar halinde kesilir (kişi başına 150 g.), 1 l. beyaz şarap, bir büyük baş soğan, 1 defne yaprağı & 1 karanfil ile birlikte ısıtılır. İlave olarak et fondüdeki soslar verilir.

### Çin Fondü / Chinesisches Fondue

Aynen et fondü gibi hazırlanır, fakat zeytinyağı yerine tavuk tableti (*Hühnerbouillon*) kullanılır.

### Et Fondü / Fondue Bourguignonne / Fleischfondue

Ocağın üzerine zeytinyağı ile dolu bakır orijinal et fondü tenceresi konur. Kuşbaşı (2 cm.), sığır bonfile (*flato / filet*) parçalarının (*yaklaşık 150 g. kişi başına*) hazırlanır, aynı zamanda et fondü çataları da. Müşteri orijinal uzun 2 uçlu fondü çatalını kuşbaşı büyüklüğündeki ete batırır & arzusuna göre kızgın yağın içinde tutar. İlave garnitür (*garnisch / beilage*) olarak dizgi çubuğu, soğan, hıyar turşusu, patates kızartması (*pommes-frites / chips*) & değişik soslar, ketçap, Worcesterhire sosu, mayonez, tatar (*tartare*), Béarnaise v.s. verilir.

## FLAMBÉ/Flambiirt/Flambéed/Alevlendirme/Alla fiamma/Alameado

Günümüzde iyi bir Chef de Rang'nın Rechaud (*reşo/ısıtıcı*) üzerinde flambé (*flambiirt*) hazırlaması için belirli bir bilgiye sahip olması gerekir. Bu nedenle bunlara ait reçetelere (*recipe - Rezept - recette*) ilgi büyüktedir.

Klasik yemek kitapları flambé üzerine detaylı bilgi veremiyor. Yalnız Maitres (*chefs / head-waiters/oberkellner/maitre d'hôtel*) & personeli pişirme sanatının bu bölümünü bilirler. Bu bilgileri değerlendirdiğimizde sadece küçük yemek seçenekleri elimizde kalıyor. Bunlarda kolay & çabuk hazırlanabilen türden yemekler, fakat insan fantazisini çalıştırıp, gönlüne göre yemekler hazırlayabilir.

Bilindiği gibi flambé yiyeceklerinin ispiertosunun alkol derecesi yüksek olması gerekir. Elinizdeki ispirotoların derecesi az ise, o zaman saf alkol kullanabilirsiniz. Bazı Maitrés (*chefs / head-waiters/oberkellner/maitre d'hôtel*) flambé için kendi özel hazırladıkları karışımları kullanırlar.

Alevlenmeyi kolaylaştırmak için, tavayı eğri tutup liqueur dolu bir kaşıkla Rechaud'un (*reşo/ısıtıcı*) alevinin yönüne tavayı gezdirmek lazım. Eğer zamanınız kısıtlı ise, önerimiz, sadece dessert'leri hazırlamanız, çünkü bunlar yemeğin sonunda verildiği için *mise en place* için vaktiniz bol olacak.

### Mise en place / Vorbereitung / Ön hazırlık :

Tuz, karabiber, kırmızı biber, irmik & kesmeşeker.

İspirtolar, domates-ketchup, worcestersauce & başka soslar. Kabuğu soyulmuş domates, krem şanti, limonlar & portakallar, küçük bir limon sıkacağı. Diğer malzemeler hardal & curry gibi yemeğin çeşidine göre kullanabilirsiniz.

### Muz Flambé

Muzları şu şekilde hazırlayınız: Uzunlamasına yarisından kesiniz, unlayınız, çırpılmış yumurtaya bandırıp yeniden unlayın. Yanyana tavaya dizip tereyağında kızartın. Yemek salonunda müşteri yanında ocağın üstüne koyun, üzerine bolca şeker serpin, kiraz likörü (*liqueur*) döküp ocağı yakınız. Kiraz likörünü alev sönünceye kadar bir kaşıkla muzun üzerinde gezdiriniz.

### Flambé şeftali venus

Tavada tereyağı eritiniz, yağ köpüklenmeye başladığında (yağı yakmayınız) yarıya veya dörde bölünmüş şeftalileri tavaya atınız. Hafif kızartınız, 1 bardak likörü (*liqueur*) üzerine dökünüz & yakınız. Alkol tam sönmeden, alevi bir kapakta söndürünüz, şeftalileri alınız & sıcak bir yere koyunuz, tavanın içinde kalan malzemenin üzerine şeftali şurubu dökünüz & biraz krem şanti (*cream/sabne/crèmel/cremal/Rahm*) ile koyulaştırınız. Elde edilen sosu şeftalilerin üzerine döküp servis yapınız.



FLAMBÉ/Flambiert/Flambéed/Alevlendirme/Alla fiamma/Flameado

Von einem guten Chef de Rang (*waiter/kellner/garson*) erwartet man heute eine gewisse Kenntnis der Zubereitung auf dem Rechaud (*reço, ısıtıcı*) Deshalb besteht ein wachsendes Interesse für die darauf bezüglichen Rezepte (*recette-recipe/reçete*). Die klassischen Kochbücher bringen in dieser Hinsicht beinahe nichts. Nur die Maitres & ihre Mitarbeiter sind es, die diesen Teil der Kochkunst kennen. Wir wanten uns daher an sie mit der Bitte um Rezepte. Die folgende Zusammenstellung enthält nur eine kleine Auswahl von Speisen, die sich leicht & rasch herstellen lassen. Es besteht natürlich die Möglichkeit, sich in dieser Kunst nach Herzenslust zu betätigen & nach eigenen Einfällen zu schaffen.

mise en place / vorbereitung / ön hazırlık :

Salz, Pfeffer, Paprika, Grieß & Würfelzucker. Spiritousen, Tomato, Ketchup, Worcestersauce & Saucen. Geschälte Tomaten, Sahne, Zi-tronen & Orangen. Kleine Zitronenpresse. Andere Zutaten wie Senf, Curry & a. je nach den Speisen, die zubereitet werden sollen.

Flambierte Bananen

Die bananen in der Küche wie folgt vorbereiten: der länge nach halbieren, einmehlen, in geschlagenes Ei tauchen & wiederum in Mehl. Auf Butter braten & nebeneinander in die Pfanne legen. Im Speisesaal auf den Kocher stellen, ausgiebig mit Zucker bestreuen, mit Kirsch begießen & anzünden. Den Kirsch bis zum Erlöschen mit einem Löffel über die Bananen verteilen.

Flambierte Pfirsiche Venus

In der Pfanne Butter heiß werden lassen. Wenn sie schaumig ist, jedoch nicht braun, die halbierten oder geviertelten (*Dosen*)-Pfirsiche einlegen. Leicht anbraten lassen, mit einem Glas Likör begießen & anzünden. Bevor der Alkohol ganz ausbrennt, die Flamme durch Aufsetzen des Deckels erlöschen lassen. Die Pfirsiche herausnehmen & warmstellen. Zur verbliebenen Tunke den Sirup gießen, mit ein wenig Sahne binden & eindicken. Dann diese Sauce über die Pfirsiche gießen & servieren.

Flambierte Bananen Elisabeth

In der Pfanne Grießzucker zu lichtgelberm Karamel brennen, einige Flocken butter dazutun, den Saft einer Orange, ein Glas Grand Marnier (*oder anderen ähmlichten Likör nach Belieben "zb. cointreau, Triple Sec, Grand Marnier"*). In diese Tunke die bereits halbierten Bananen legen & 3-4 Minuten schmoren lassen. Dann mit einem Glas Cognac begießen & anzünden.

Ananas Hawaii - Paradies

In der Pfanne Butter zerlassen, einige Zuckerwürfel, die man vorher an einer Orangenschale gerieben hat, dazugeben. Sobald der Zukker sich löst, die Ananasschnitten (*aus der Dose*) in die Pfanne legen & beiderseits leicht anbraten. Mit Rum begießen & anzünden. Ananassirup dazugießen & weitere 3-4 Minuten schmoren lassen. Auf jeden Teller 1 oder 2 Scheiben Ananas servieren, in die Mitte des Ringes eine schöne Pflaume stecken, dann mit der Sauce aus der Pfanne übergießen.

## • COCKTAIL & TARİHÇESİ

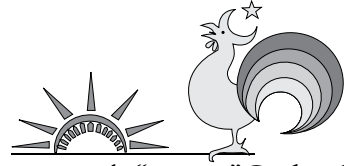

Adı gibi karışık, içimi gibi mahsun, rengi kadar cazip & poetik “*sairane*” **Cocktail** sözcüğü Anglo-Amerikan menşeli olup, **queue de coc/hahnen schwanz** deyiminin, yani **Horoz Kuyruğu**’nun anlamdaşdır.

Gerek Münih’teki özel otelcilik öğrenimim, gerekse okul sonrası Münih Park - Hilton’un Bankett kısmında extra (*aushilfe*) çalıştığım sıralar, aklım hep bu 2 heceden ibaret olan kelimeye takılır; ister istemez, insanı Binbir Gece Masallarının düşünce & çağrışım yumağına iten bu değişik renk cümbüşünün oluşturduğu karışım/ suspension hakkında, birgün meslekdaşlarıma etraflı bilgi verebilme gereği duyar & bu arzuyla yanar tutuşurdum. Sizlere, Avrupa’nın eski bar Chef’lerinden **Herr Soltan, Mr. Deck, Herr Schumann, Maitre d’Hotel Herr Meixner**’in dökümanları & servis hocam **Herr Kollmann**’ın uygulamalı öğrettikleri doğrultusunda **cocktail & tarihçesi** hakkında açıklamalarda bulunacağım.

1806 yıllarında, sıcak bir yaz gününde, Amerika’da yayınlanan **The Balance** gazetesinin meraklı okuyucularının gözlerine şöyle bir yazı takılır. **Cocktail**; çeşitli iştahatlı içkiler, şeker, su, tatlandırıcılar & bitter soslardan, örneğin : angostura bitter, orange bitter, worcestershiresauce, grenadine syrup, Nutmeg (*muskatnuß / hint cevizi / (Noix de) muscade / muscat / Noce moscata / Nuez moscada*) vs. oluşan & politika konuşmacıları için cesaret arttırıcı olarak bilinen bir içki çeşidi cocktail ile tanıştınız mı? Gerçekte cocktail’in doğuş tarihi 1806 olarak kabul edilse bile öyle görünüyor ki,

**politikacılar bar atmosferinin sisli havası içinde yaşamlarını sürdüren barmen’lerden daha önce cocktail ile tanışmışlar.**

Cocktail’in tarihçesi hakkında kesin bir bilgi olmamasına rağmen eskiden beri bar sohbetlerinde konuşulanlardan günümüze kadar gelen bilgilere göre çeşitli rivayetler ortaya konulmuştur.

**Örneğin**; vahşi batıda yaşayan bar sahiplerinden biri çok sevdiği hint horozunu kaybetmiş. Olaya çok üzülen bar sahibi horozunu bulana güzel kızını vereceğini vaat etmiş. Birkaç gün sonra elinde bir horozla bar’a giren yakışıklı cowboy’u gören bar sahibi sevinçle, doğru kızına gitmiş & acele en iyisinden bir içki hazırlamasını emretmiş. Babasının heyecanından, ya da yakında evlilik görünmesinden olacak ki, güzel kız titreyen elleriyle önünde bulunan likörler & sert iştahatlı içkileri birbiri ardına karıştırarak bir bardağa (*kadeh*) doldurmuş & bardakta oluşan renkli sıvıya bakıp, bulunan horozunun renkli kuyruğuna benzeterek içkiye **horoz kuyruğu / hahenschwanz “cocktail”** adını vermiş.

**İlk cocktail bar, Alexis Soyer adında bir İngiliz tarafından Londra Hyde Park yakınlarında “Gore House” adı altında 01 Mayıs 1851 yılında açılmış.**

Fakat cocktail’in tarihçesinde, cocktail hakkında başka şeyler de anlatılır. 1920’lerde içki severler **Stinger** adı altında bir içkiyi iyice benimsemişlerdi. Stinger aslında Amerika’nın yokluk yıllarında doğan bir içki çeşidi idi. Stinger içinde çoğunluğu Bathup Gin adı ile bilinen & banyo küvetinde destile edilen, gerçekte ateş suyu gibi tadı olup, içilemeyecek kadar sert bir içki çeşidi idi. Bu içkiyi içebilmek için şekerli fazla olan meyve suları, aromatik esans & tadı güzelleştiren kremşanti (*cream-sahne*) ile yumurta konulurdu.





Bu karışımı içenler berbat bir tadı olmasına rağmen, ona zamanla alıştılar. Stinger Amerika'da moda olduktan sonra şişelenerek Avrupa'ya ihraç edildi. Bundan başka dünyanın gidişatı çok iyi olan eski zamanlarda, insanlar cocktail adı altında başka şeyler de anlıyor & yaşıyorlardı.

O zamanlar efsanevi **KC-25** adı altında bir cocktail vardı. Ne! **KC-25**'i tanımıyor musunuz? (**Der Kniekehlencocktail -1925 / diz arkası çukuru kokteyl**) Üzülmeysin, Dünya'da birçok barchef/barkeeper bu adı ya hiç duymamışlardı ya da bilenler bu cocktail'i hazırlamakta güçlük çekmişlerdir. **Zira cocktail'e dahil olan içkilerin yokluğundan ziyade, hazırlanmasında kullanılan shaker veya mixglass'ın çok zor bulunmasındandı.** Bu güçlük şuradan doğuyordu, shaker olarak eti budu yerinde bir bayan bacağına ihtiyaç vardı. Hazırlanışı da güzel; etine dolgun bayan bacağı dizinden kıvrılır, diz altında oluşan çanak içine bir miktar vermouth konulurdu. Olayı daha çekici yapmak için de biraz şampanya ilave edilirdi. Eğer güzel bayan gıdıklanmıyorsa bu cocktail **pipett**'le (*straw-strohhalm-trinkhalm/chalumeau*) de içilebilirdi. Tabii ki bu içki içme usulü ancak alışılmışın dışındaki kalburüstü kişiler arasında tatbik edilirdi.

Normal vatandaşların daha çok rağbet ettiği cocktail çeşitleri ise, White Lady-gin fizz-old fashioned-screwdriver/ tornavida-Bloody Mary - Planters Punch & Martini Dry'dır. Bugün 4000'e yakın bilinen & tatbik edilen cocktail reçetesi vardır. İyi bir barchef bunların ancak 1/5'ini bilir, shaker ile cocktail'ini hazırlar & satmalıdır. **Cocktail, tiryakileri için iştah açıcı, neşe arttırıcı, damakta hoş bir tat & gözlerde bir canlılık bırakıcı olması, bundan başka cocktail'in insanı hayallere sürüklemesi lazımdır.**

İyi bir cocktail'in nasıl olması hakkındaki soruların cevabı ise, onu içenin hayallerinde yatan şeye bağlıdır. Ben derim ki; iyi bir cocktail; çok güzel akort edilmiş bir müzik aletine benzer, **harmonik & dört dörtlük (4/4),/ harmonisch & (4/4)**

Adnan Mert



cocktail KC-25 (Der Kniekehlencocktail -1925)  
"diz arkası çukuru kokteyl"

## • COCKTAIL & SEINE GESCHICHTE

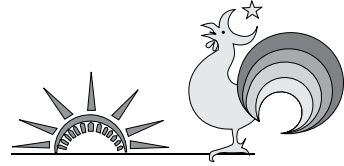

Gemischt wie sein Name, betrübt wie sein genuß, reizvoll & poetisch wie seine Farbe ist das wort cocktail, das vom Anglo-Amerikanischen ursprung abstammt & gleichbedeutend ist, wie der Ausdruck, queue de coc, das heißt hahnenschwanz (*horoz kuyruğu / cocktail*).

Sei es während meiner speziellen Hotel ausbildung in München oder sei es während der zeit nach meiner Ausbildung, als ich noch extra (*Aushilfe*) in der Banquetabteilung des Münchener Park - Hiltons arbeitete, bleibt mir dieses wort bestehend nur aus zwei silben, in meinem Gedächtnis hängen. Ich fühlte mich schon immer dazu gezwungen, meinen mitmeschen ausgedehnte informationen über diese misc-hung (*suspension*) zu geben das aus einem ungewohnten farbfest besteht, daß den Menschen unwillkürlich in den Gedanken & Assoziationstaumel der Tausend & eine nacht märchen treibt. Dieser Wunsch entfachte schon immer ein Feuer in mir.

Ich werde ihnen heute ein Erklärung über dem cocktail & seine geschichte geben, die mit den dokumenten der alten & neuen europäischen Barchefs Herrn Soltan, Mr. Deck, Herrn Schumann & des Maitre d'Hotel's Herrn Meixner & der theoretischen so wie auch praktischen lehre meines Servicelehrers Herrn Kollmann, übereinstimmt.

An einem warmen sommertag des jahres 1806 bleiben die Augen der neugierigen leser der zeitung The Balance, die in Amerika veröffent licht wird, an folgender zeile hängen:

Cocktail; haben sie schon das alkoholische getränk Cocktail kennengelernt, das als Mutsteigerer der politischen Redner bekannt ist, & aus verschiedenen spiritusgetränken, zucker, wasser, Aromastoffen & bitter, worchestershire sauce, grenadine syrup, **Nutmeg** "*muskatnuß / hint cevizi / (Noix de) muscade / muscat / Noce moscata / Nuez moscada*" e.t.c.) besteht?

Auch wenn man das wirkliche Geburtsdatum des cocktails als 1806 anerkennt, sieht es doch so aus, als seien die politiker eher mit dem cocktail bekanntgeworden als die Barmänner, die ihr leben in dem Nebeldunst der Baratmosphäre verbringen. Auch wenn es keine genaueren Kenntnisse, über die Geschichte des Cocktails gibt, druch-drangen unsere zeit verschiedene überlieferungen (*gerüchte*), die man sich gegenseitig seit der frühesten zeit während der Barunterhaltung erzählt hat.

Einer der Barbesitzer im Wilden Westen, soll seinen indischen Hahn verloren haben, den er sehr liebte. Dieser Barbesitzer, der sehr traurig über dieses Ereignis war, soll demjenigen, der seinen Hahn wieder findet, seine Tochter versprochen haben. Als er einige Tage später einen gutaussehenden Cowboy mit einem Hahn in der Hand in seine Bar eintreten sah, soll er voller Freude zur seiner Tochter gelaufen sein & ihr befohlen haben, sofort eins der besten Getränke vorzubereiten. Entweder vor Aufregung ihres Vaters oder vor der bevorstehenden heirat, soll das hübsche Mädchen mit ihren zitternden Händen all die liköre (*liqueurs*) & die harten spiritusgetränke, die vor ihr standen, nacheinander gemischt & in ein Glas gefüllt haben. Als sie die entstandene bunte flüssigkeit sah, fand sie, das es dem bunten schwanz des Hahnes ähnelte & soll diesem Getränk den Namen Hahnenschwanz /horoz kuyruğu/cocktail gegeben haben.

Die erste cocktail Bar wurde am 01 Mai 1951 von einem Engländer namens Alexis Soyer in der Nähe der Londoner Hyde Park unter dem Namen "Gore House" eröffnet. Aber in der cocktail - Geschichte werden auch andere Sachen über den cocktail erzählt, in den 30 er Jahren wurde ein Getränk namens, stinger von den Getränkeliebhabern fest anerkannt. Stinger war eigentlich eine Getränkeart, die in dem Amerikanischen Armutsjahre entstand. Stinger, in dem sich größtenteils Bahtup gin befand & der in Badewannen destilliert wurde, hatte den Geschmack von Feuerwasser & war ein Getränk , so das man es nicht trinken konnte. Damit dieses Getränk trinkbar wurde, wurden Fruchtsäfte mit hohem Anteil an Zucker, aromatische Essense & sahne dazugemischt, die den Geschmack verschö-neren. Obwohl es einengräßlichen Geschmack hatte, gewöhnten sich die Genießer dieser Mischung mit der Zeit daran. Nachdem stinger in Amerika Mode war, wurden Flaschen abgefüllt & nach Europa exportiert. In den alten Zeiten, die einen sehr schönen Verlauf hatten, verstanden & erlebten die Menschen unter dem Namen Cocktail außerdem auch noch andere Dinge, in diesen Zeiten gab es einen cocktail unter dem sagenhaften Namen **KC-25** Was! Sie kennen **KC-25** nicht?

**(Der Kniekehlecocktail -1925 / diz arkası çukuru kokteyl)** Aber seien Sie nicht traurig, sehr viele Barchefs in der Welt haben diesen Namen entweder noch nie gehört oder die, die ihn kennen, hatten Schwierigkeiten, diesen cocktail vorzubereiten Obwohl es nicht nur am Mangel der daraus bestehenden von verschiedenen Getränken lag, sondern auch daran, daß man dem shaker & das Mixglass, die man brauchte, um es vorzubereiten, sehr schwer finden konnte. Diese Schwierigkeit war folgende: man brauchte als shaker ein üppiges Damenbein - Die Vorbereitung war auch schön : Man beugte das üppige Damenbein am Knie, füllte die Grube, die unter dem Knie entstand mit ein wenig vermouth. Damit dieses Ereignis noch reizvoller wurde, fügte man noch ein wenig champagner dazu. Falls es dieser schönen Dame nicht kitschig wurde, durfte man diesen cocktail auch mit Strohalm (*trinkhalm/ pipette/chalumeau/straw*) trinken. Natürlich wurde diese Art von Trinkerei nur unter dem ungewohnten reichen Leuten ausgeübt.

Die normalen Mitbürger verlangten nach anderen cocktailsorten wie, White Lady-Gin fizz-old fashioned-screwdriver/ tornavida - Bloody Mary - Planters Punch & Martini Dry. Heute gibt es bis zu 4000 cocktail sorten, die man kent & ausübt. Ein guter Barchief kann nur 1/5 davon mit seinem shaker mixen.

Cocktail, ist für leidenschaftliche ein appetitanreger, mutanreger, im Gaumen einen angenehmen geschmack & in den Augen einen lebhaften Blick zu hinterlassen. Außerdem muß der Cocktail die Menschen in phantasien mitschleifen. Die antworten zu den Fragen, wie ein guter cocktail sein muß, ist was der Trinker in dem augenblick in seiner phantasie hat & ich sage; ein guter cocktail ist ähnlich wie ein gut akkordiertes Instrument, **harmonisch & (4/4)**.

Adnan Mert



## • HISTORY OF COCKTAIL

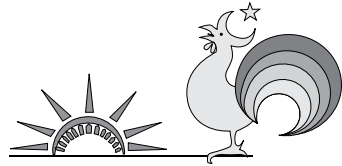

The word Cocktail comes from Anglo-American language meaning ' tale of cockrel ' it is full of attractive colours brings a poet out of you.

During my studied at Munich Tourism school in my spare time I worked at Munich park Hilton Hotel & one word that I learn in there, made a big impact in my mind that I never forget ' Cocral Tale ', & I promise myself that one day I will tell you in detail what is this word about & what makes it that most people get hooked up to it.

I will tell you some recipes & also history of cocktails from well known barmen chefs of the world such as Mr Deck, Herr Soltan, Herr Schuman, Maitre d Hotels Herr Meiyner.

It was warm summers night in 1806, followers of the Balance newspaper saw a very interesting article title was Cocktail!! made from various spirits, sugar, water, sweeteners & bitter sauce, for example ; Angostura bitter, Orange bitter, Worchester sauce, grenadine syrup, Nutmeg, etc. Have you had this kind a drink that will give courage to politicians to talk more independent speech!!

The date that Cocktail is born may be in 1806, however Barmen's that breaths that smokey atmosphere may found that mixed drink well before that date further more some story tells us

that One day one of the Bar owner at the west coast looses his Cockerel, He was so attached to him that he promised to let that men to marry his daughter, a few days later One young men enters the bar with his cockerel under his arm, he orders a drink, with that excitement she pours a few spirits & liquars into a large glass, bar owner notices the colours in the glass that was very similar colours to that cockerels tale then he names that drink ' Cockerels tail ' short Cocktail.

First Cocktail bar opened its doors in 1st of May 1851 at Hythe Park in London, Bar was called Gore House.

Very many different thinks has said about History of Cocktail, some says, cocktail named Stinger were served 1920's & actually very many drinkers were attached to it but saying this, some says Stinger has been in Cocktail Bars in early years in America's recession times, That time Stinger made of Bath tab Gin, (it was called then ) brewed in a bath tub tasted like aromatic fire burns in your mouth, it was very strong that, in order to become drinkable they have to mix it fruit juice, cream-sahne, & egg, this drink may test like s...t but people loved it.

Stinger has become a fashionable drink in America then exported to Europe, then become more & more popular with different spirits and juices. Around that time cocktail name **KC-25 (Der Kniekehlecocktail -1925/ diz arkası çukuru kokteyl)** was born, you may not know it (don't worry most of Cocktail chefs may not know it ), at fist they used to drink it from Ladies

Leg with straw( she was bending her leg from the knee so between bottom part & the top part her leg forms a like a bowl).  
Most common cocktails were & is White Lady, Gin fizz, Old fashioned, Screwdriver / tornavida, Bloody Mary, planters Punch & Martini Dry.  
Today there are nearly 4000 known cocktail drinks but most of Cocktail Chefs may only perhaps 20 percent of this. Cocktail Drinks should have irresistible lust, attractive colours, it should drive you beyond your imaginations.  
For me the best Cocktail is like a musical instrument that perfectly accorded & ready to give you perfect sound. **harmonik & drt drtlk (4/4)./ harmonisch & (4/4)**

Adnan Mert



**cocktail KC-25 (Der Kniekehlencocktail -1925)  
"diz arkası ukuru kokteyl"**



## • BRANDY'NİN TARİHÇESİ (WEINBRANT/GEBRANNTEN WEIN/KOGNAC/KANYAK/ COGNAC)

Yunanlılar & Romalılar şarabı tanıyıp öğrenmişlerdi & değerini iyi biliyorlardı, fakat onu henüz damıtmamışlardı (*brandy: bakır kazanın “imbik” altını yakıp şarabı kaynatarak damıtmak “destille etmek”.*)

Avrupa’da brandy (*Wein brennen / Gebrannten Wein*) hakkındaki ilk belgeler (*dokümanlar*) **12. Y.Y.**’a dayanır. *“Mappae clavicula”*, ortaçağın tekniği hakkındaki bir kitapta bile bundan bahsediliyordu.

Damıtmaya *“aqua ardens”*, **yakılacak** (*brennbares*), veya **yanan su** (*brennendes*

*/ateş suyu*) denilirdi. O sadece yanmıyordu, aynı zamanda tıp’ta da o kadar iyileştirmeler gösteriyordu ki, bir asır sonra Bologna / İ., Üniversitesi’nden **Professor Taddeo Alderotti** *“aqua vitae”* yaşamın suyu & onu **bütün ilaçların kraliçesi** olarak tanımlamıştı. Fransa’da *eau-de-vie*, İtalya’da *“aqua viate”*, *“Wasser des Lebens / Water of Life / Hayat Suyu”* &

*“Königin aller Arzneien”* olarak günümüze kadar gelip benimsenmiştir. İspanya’da ise *aguardiente* olarak tanımlanmıştır.

İmbikteki şarabın yakılıp, kaynatılarak damıtılması *“destille edilmesi”* (*Weinbrennen*) **1250** yıllarında Almanlar’a pazarlama merkezi *Brügge - Flandern/ GER.* üzerinden gelmiştir. **1317** yılından günümüze kadar Kuzey Almanya’nın Hanse bölgesinde **Bernewater** adı kullanılır, tam anlamıyla *aqua ardens* (*yanan su / brennendes wasser*).

**1365**’dan itibaren güney & orta Almanya’da damıtımcı (*Weinbrenner / destilliermann / Stillman / destilleci, destille eden*) soyadı olarak da kullanılmaya başlanmıştır.

**1321** yılından sonra ise Heidelberg’de (GER.) bir yazıda *“gebrennit win”* adıyla anılmıştır.

**1351** yılında Berlin’de bir eczacıya (*destillier Gesellschaft*) damıtım derneği *“birliği”* kurma görevi verilmişti. Başka şehirlerde de ihtiyaçları karşılama görevi bu mesleki damıtımcılara verildi.

Almanya’dan sonra **14. Y.Y.** ortalarında şarabın damıtılması (*Weinbrennen*) Fransa’da da tanındı, **300 yıl sonra** Fransa’da bir kasaba adı olan **Cognac** (*brendi / gebrannten Wein*) damıtılmış şarap kavramı oldu.

Almanya’da da damıtılan şaraba *Cognac* ya da **1909** şarap kanununa göre *Alman Kognac* (*Deutscher Kognac*) adı veriliyordu, fakat 1.Dünya Savaşı & **1919 Versailles anlaşması**’ndan sonra Almanlar *Cognac* kelimesini kendi üretimleri için kullanamadılar.



1923'deki şarap kanununa göre, **Alman damıtımcı Hugo Asbach'a** (*Destilliermann / Weinbrenner / Stillman / destille edici*) damgalı "kaşeli" ilk belge: "Weinbrand" verildi.

1985 yılında Bursa'da (TUR.) Türkiye'de ilk defa **Piccolo Bar** bar ünvanı ile, "mixolog & gastronom" unvanını kullandı & "mixology & gastronomy" adlı akademik eserlerinde "kokteyl & tarihçesi" yazıldı, atölyelerinde ilk bar üstü **asma bar'ı** imal ettiler.

1989 yılında İstanbul'da (TUR.) ilk defa bar işletmeleri, Barmenler Derneği "**Birliği**" (*B.B.D. "B.A.T."*) **kurucu başkan M. Muhammed Arslan, kurucu başkan yrd. Adnan Mert & kurucu üyeler Ragıp Bora, Mahmut Topçu, Niyazi Arslantaş, Ziya Akkaş, Celal Kocaoğlu** tarafından kurulmuştur. **pré dinner, after dinner, long drink** kategorilerinde Türkiye'nin çeşitli bölgelerinde kokteyl yarışmaları düzenleyip, eğitim & seminerler vermişlerdir.

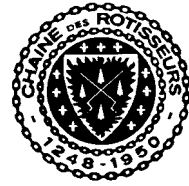

### DAMITMA / DESTILLATION:

**1.damıtma (distillation / distillate / destillat / 1.koşu (baş mahsul), 1.taktir / 1.vorlauf / 1.leap / Premier brouilli "kalitesiz"):** Aslında şarap nasıl yakılır & yanmada (*brennen*) neler olur? Su 100 °C'ta kaynayıp buhar olur. Fakat alkol 78.3° C'de kaynayıp buharlaşır & içinde bakır spiral bulunan soğutucudan (kühler) geçip, fiçılara akar. Önce şarap ön ısıtıcıda (*Vorwärmer*) 40 °C'a getirilir. Oradan bakır kazana (*kupferne kessel / Alembic / imbik, imbik*) akar. Isıtılmış borulardan geçen şarap istenilen hararet derecesine gelir. Sonra alkol zengini buhar imbikten soğutucuya geçer. Burada şarap kendi karakteristik tadını kazanır. Yaklaşık alkolü % 40'tır & tadı adı gibidir.

**2.bölüm, "Herzstück, goldene mitte / yürek parçası, ana yürek", (distillation / distillate / destillat / 2.koşu (orta mahsul), 2.& orta takdir (altın ortası, suma, tabii, saf alkol) / 2., miltellauf / 2.leap / Deuxime brouilli "kaliteli**



*kısım, en az 2 kere damıtılmış*” 2. yanma yöntemi, ilk koşu (*Vorlauf / Premier brouilli / “kalitesiz”*), orta koşu (*Mittellauf / Deuxime brouilli / “kaliteli, en az 2 kere damıtılmış”*) & son koşu, son taktir, son mahsul, kuyruk (*Nachlauf*) diye 3' e ayrılır. Bu iç içe giren damıtım bölümlerinin itina ile birbirinden ayrılması gerekir. Orta koşu (*yürek parçası (kalp) / Herzstück / Deuxime brouilli / kaliteli*) anadamatımın yapıldığı bölümdür. –*fiairane (poetisch) olarak “kalp” veya “kalp parçası” olarak adlandırılır.*– & alkolün en kalitelisidir, en az 2 kere damıtılması gerekir. Rengini bir cins meşe ağacından yapılan fiçılardan alır. (Limousineiche Fass / cins meşe fiçası) ilk (*Vor / Premier brouilli*) & son koşularda (*Nachlauf / Troisieme brouilli / “kalitesiz”*) ise oluşmakta olan brendiden (*Weinbrand / Brandy / Kognak / Cognac*) istenmeyen yan maddeler ayrılır.

Damıtım işinde modern teknolojinin getirdiği alet, bilgisayar, makina veya diğer yardımcı modern cihazlar kullanılmayıp, tamamen damıtım ustalarının (*Brennmeister*) tekniği ile tarihten günümüze ilkel şekilde yapılmaktadır.

**3.Bölüm, 3.damıtma (distillation / distillate / destillat / 3.koşu (kuyruk), 3.takdir, son mahsul / 3. nachlauf / 3.leap / Troisieme brouilli):** Kristal berraklığındaki damıtmanın depolanması bir cins meşe (*Limousineiche*) fiçılarında doldurulup depolanır. Şarap kanununa göre brandy (*Weinbrand*) minimum 6 ay fiçıda kalmak zorundadır. Bu depolama sayesinde brandy (*Weinbrand*) olgunluğuna & kalitesine erişir. Eski kanunlarda ise depolama süresi en az 12 aydır. Bu zaman zarfında fiçi gözeneklerinden (*Faßsporen / çeperleri*) oksijen girdiğinden & fiçılardan kaybedilen ~ % 3 alkol buhar olup gökyüzüne gider. Buna da alkolün payı (*Teil des Alkohols*) veya anlamlı olarak;

**(Teil der Engel) MELEKLERİN PAYI denir.**

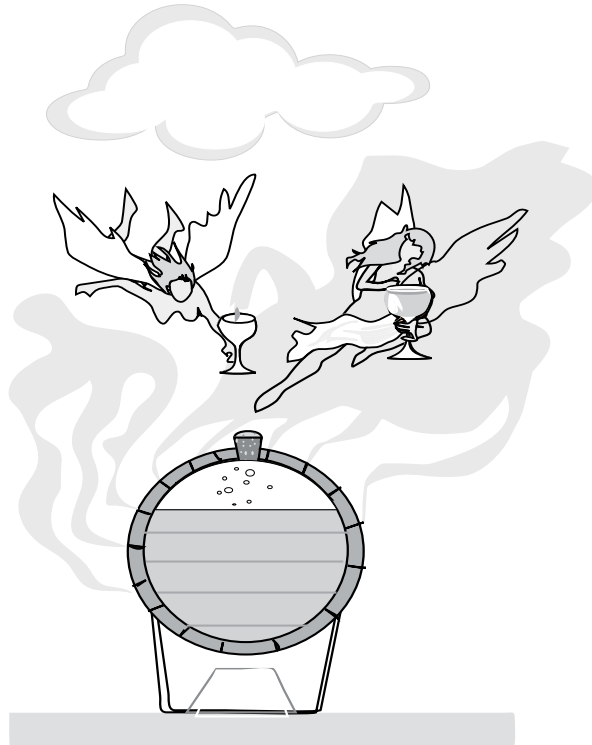

## HISTORISCHES VOM GEBRANNTEN WEIN /

### BRANDY'NİN TARİHÇESİ (WEINBR& / GEBRANNTEN WEIN / KOGNAC / KANYAK / COGNAC)

Griechen & Römer kannten & schätzen den *Wein-gebrannt* haben sie ihn aber noch nicht. Erste Zeugnisse über das Weinbrennen in Europa gehen auf das 12. Jahrhundert zurück. *“Mappae clavicula”*, ein Buch über die Technik des frühen Mittelalters, weiß bereits davon zu berichten. Das Destillat wurde *“aqua ardens”* genannt, *“brennbares”*, aber auch *“brennendes”* Wasser. Es brannte aber nicht nur, es hatte auch so eindrucksvolle Heilwirkungen, daß es ein Jahrhundert später bei **Taddeo Alderotti, Professor** an der Universität Bologna, als *“aqua viate”*, *“Wasser des Lebens / Water of Life / Hayat Suyu”* & *“Königin aller Arzneien”* erscheint dieser Name ist in Frankreich als *eau-de-vie*, in Italien als *acquavite* bis heute geblieben, während *aqua ardens* im spanischen *aguardiente* enthalten ist.



Um 1250 ist die Kenntnis des Weinbrennens, zuerst auf dem Seeweg über das Handelszentrum Brügge in Flandern, zu den Deutschen gekommen. Seit 1317 gibt es im niederdeutschen Raum der Hanse den Namen *Bernewater*, was genau *aqua ardens*, *“brennendes Wasser”*, ist, & seit 1365 in Süd & Mitteldeutschl&den Namen *Weinbrenner* der aus dem Berufszum Familiennamen geworden war. Schon 1321 handelt eine Handschrift in Heidelberg von *“gebrennit win”*.

In Berlin wird 1351 dem Ratsapotheker ein Monopol für das Destillieren von Wein erteilt. In den meisten anderen Städten sind es gewerbliche Weinbrenner, die bald einen großen Verbrauch zu befriedigen haben.

Wenig später als in Deutschl&& zwar in der Mitte des 14. Jahrhunderts, wird das Weinbrennen auch in Frankreich bekannt. Weitere 3 Jahrhunderte später wird das französische Städtchen *Cognac* zum Begriff für *gebrannten Wein*.

Auch in Deutschl&trug fast alles, was aus Wein gebrannt war, die Bezeichnung *Cognac* oder –wie es im Weingesetz von 1909 verankert war– Deutscher *Kognak*. Das änderte sich jedoch nach dem 1. Weltkrieg, als nämlich durch den Versailler Vertrag von 1919 das Wort *Cognac* für deutsche Erzeugnisse nicht mehr verwandt werden konnte. Der Gesetzgeber übernahm dafür im Weingesetz von 1923 die von dem deutschen **Weinbrenner Hugo Asbach** um die Jahrhundertwende geprägte Bezeichnung *Weinbrand*.

1985 hat in Bursa/Türkei das erste mal die **Barantico Bar** den Namen *“mixologie & gastronomie”* (*mixology & gastronomy*) verwendet & im *Piccolo Buch* haben sie *“Cocktail & seine Geschichte”* geschrieben, Den ersten **Hängebar / bar üstü asma bar** haben sie im eigenen Atelier gemacht.

1989 wurde in İstanbul (TUR.) deß erste Barbetrieb, **Barmänner Gesellschaft (B.A.T. “B.B.D.” / Bartenders Association of Turkey)** von **Präsident M. Muhammed Arslan, Vice präsidant Adnan Mert & den Mitgliedern**

Ragıp **Bora**, Mahmut **Topçu**, Niyazi **Arslantaş**, Ziya **Akkaş**, Celal **Kocaoğlu**,  
gegründet in manchen teilen der Türkei wurden in den kategorien **pré dinner**,  
**After dinner, long drink**

Meisterschaften veranstaltet .



### DESTILLATION (distillate / damıtma):

*1.damıtma (distillation / distillate / destillat / 1.koşu (baş mahsul), 1.takdir / 1.vorlauf / 1.leap / Premier brouilli “kalitesiz”):* Wie wird nun Wein überhaupt gebrannt, & was passiert eigentlich beim Brennen? Um dies zu verstehen, müssen wir zunächst ein wenig naturwissenschaftlich sein: Wasser siedet bei einer **Temperatur von 100°C** & geht in Dampf über; bei Alkohol ist dies aber schon bei **78°C** der Fall. Erhitzt man also Wein & kühlt den dampf in einer wasserumspülten Kühlturbine sogleich wieder ab, so ist das sich niederschlagende Destillat naturgemäß alkoholreicher als der Ausgangstoff.

In der Praxis kommt der Wein zunächst in Vorwärmer & wird auf eine **Temperatur von 40°C** gebracht. Von dort fließt er in große kupferne Kessel, die Brennblasen. Beheizte Röhre bringen den Wein darin auf die zum Verdampfen erforderliche Temperatur. Die mit den wertvollen Bukettstoffen des Weines angereicherten alkoholreichen Dämpfe steigen empor & gelangen durch den Helm der Blase in die **Kühlzylinder (soğutucu silindir)**. Der Wein gewinnt hier –nunmehr in konzentrierter Form und kristallklar– seine flüssige Eigenschaft wieder. Das Ergebnis dieser Destillation wird als Rauhbr& bezeichnet. Er hat *ca. 40 % Alkohol* & schmeckt so, wie sein Name klingt. Erst durch eine zweite Destillation wird der Rauhbr& verfeinert.

*2.bölüm, “Herzstück, goldene mitte / Yürek Parçası, Ana Yürek”, (distillation / distillate / destillat / 2.koşu (orta mahsul), 2. & orta takdir (altın ortası, suma, tabii, saf alkol) / 2., mittellauf / 2.leap / Deuxime brouilli “kaliteli”*

Beim zweiten Brennvorgang unterscheidet man zwischen Vorlauf, Mittellauf & Nachlauf. Diese einzelnen ineinander übergehenden Destillations- abschnitte müssen nun sorgfältig getrennt werden. Nur der Mittellauf - den man etwas poetischer auch das **“Herz”** oder, **“Herz stück”** nennt - wird später einmal zu Weinbr& werden. Vor & nachlauf hingegen werden ausgeschieden, da sie unerwünschte Nebenstoffe enthalten.

Jenes qualitativ allein für den Weinbr&in Frage kommende Herzstück genau herauszufinden, ist der wichtigste Vorgang der Weinbrandherstellung & verlangt die volle Aufmerksamkeit des Brennmeisters. Da gibt es keine Maschinen, keine Computer oder andere moderne hilfsmittel, & man wird die große Kunst dieses Fachmannes nie ersetzen können. So war es schon im Mittelalter, & so wird es auch bleiben. Viele Faktoren spielen dabei eine Rolle. Da sind die Temperaturen während des Brennvorganges genau zu regulieren, um die Hitzegrade zu erreichen, die für das Gewinnen der Bukettstoffe am günstigsten sind. Da muß ständig der schwankende Alkoholgehalt des herauslaufenden Destillats überwacht werden, & schließlich muß der Brennmeister durch Geruchs- & Geschmacks- proben den Mittellauf exakt vom Vor- & Nachlauf trennen. Zu einer ganz besonderen Begabung & einer sorgfältigen Schulung gesellen sich bei diesen Spezialisten immer langjährige Erfahrung & eine nie nachlassende Aufmerksamkeit. *3.Bölüm, 3.damıtma (distillation / distillate / destillat / 3.koşu (kuyruk), 3.takdir, son mahsul / 3. nachlauf / 3.leap / Trousieme brouilli "kalitesiz"):*

Die Lagerung des kristallklaren Destillats erfolgt in kleinen Fässern aus dem wertvollen Holz der Limousineiche. Das Gesetz schreibt vor, daß der Weinbr& mindestens sechs Monate auf kleinen Eichenholzfässern gelagert haben muß. Durch diese besondere Art der Lagerung gewinnt der Weinbr& seine Reife & Qualität. Bei einem Alters- hinweis schreibt das Gesetz eine Mindestlagerzeit von **12 Monaten** vor.

Während der Lagerdauer laufen eine Reihe komplizierte Vorgänge ab. Zunächst der Zutritt von Sauerstoff durch die Faßsporen (*çeperleri / gözenekleri*). Dabei verdunstet aber auch ein **Teil des Alkohols** (*alkolün payı*). Man nennt ihn gem den **TEIL DER ENGEL** (*meleklerin payı*). durch diesen Austausch ent-stehen erwünschte Geschmacksstoffe, die dem Weinbr& seine weiße Milde geben. Gleichzeitig entwickeln sich aber auch Ester, jene Duft & Aromastoffe, die für die spätere Blume sorgen. Das Holz des Fasses gibt dem Weinbr& wertvolle Extraktstoffe, & dabei entsteht allmählich die goldbraune Farbe.

Holz eutstammt der Natur, & so wie jedes Faß naturbedingt ein wenig anders ausfällt, entwickelt sich auch das darin befindliche Destillat anders als das im nächsten Faß. Nach angemessener Zeit füllt man deshalb den Inhalt der Fässer in einen großen Bottich zum "**Egalisieren**", also zum Vermischen. Die Reife geht aber anschließend in den kleinen Fässern weiter.

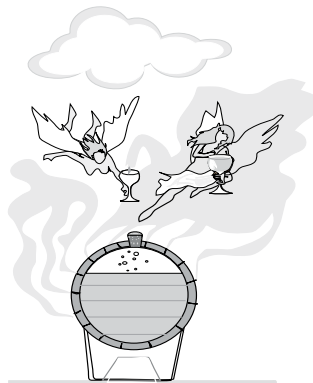

**(Teil der Engel) MELEKLERİN PAYI**



## HISTORY OF BRANDY

Greeks & Roman's enjoyed the wine but didn't know how to distille it, it is unknown when people discovered the grapes, plums, rice, corn that could converted in to a alcohol through fermentation.

The dicoverly of fermentation occured about sametime with the rise of the first civilazation & about sametime people in Europe discovered apple & grape juice would ferment into strong cider & wine, Distilled spirits were made in India as long ago as 800 B.C , The Arabic Scientist Jabir ibn Hayyan (known as Geber in the West ) described distillation in detail in the 8th century, in Latin Brandy is known as aqua vitae, which translates as "*aqua viate*", "*Wasser des Lebens / Water of Life / Hayat Suyu*" & "*Königin aller Arzneien*", the French still refers to Brandy as 'eau de vie ' meaning exactly same thing, The word whisky comes from the



Gaelic phrase " uisge heatha " also meaning water of life. People in the Middle Ages attributed magical, medicinal properties to distilled spirits, recomending it as a cure for almost every health problems. In 1250 Germans distilled it in Flander-Germany which came via Brügge, from year 1317 People in the Hanse area of north Germany called it Burning water, later on in around 1365 people in middle & south Germany used this name too, from year 1321 peple in Heidelberg called it ' gebrennit wine ', in 1351 Berlin Germany first distillation federation formed. France first met Brandy in mid 14th century, 300 years later the name of Cognac has given its name the first distilled brandy with wine in the Cognac region in France.

Germans used to use this name but in 1919 with the Versay agreement they could not used the name ' German Cognac '.

The name Brandy comes from the Duch word ' brandewijn ' meaning " Burnt Wine ". Most brandies are made by applying heat originally from open flames to wine, the heat drives out & concentrates the alcohol & presents in to a wine. Because alcohol has a lower boiling point ( 78 °C ) then water (100 °C ), it can be boiled off while the water porsion of the wine remains in the still.

Heating a liguid to separate components with different boiling points is called heat distillation. While brandies usually made from wine or other fermanted fruit juice, but it can be distilled from any liguid that containd sugar.

Almost every countries have their own national brandy, many of which are made from wine ; grappa in Italy is made from grape skin, slivivitz in Pol& made from plums, bourbon in the USA is made from corn, shochu in Japan is made from rice. it is univerally acknowldage that the finest brandies are the French cognacs that are distilled from wine.

In 1985 Piccolo Bar ( Bursa-Turkey ) has written a book called 'mixology & gastronomy' , this book includes an article about cocktails & its history & also they are the first Bar to create a 'suspension shelving' . In 1989 first time in Turkey Barmen's Society formed, their founders were/are M. Muhammed **Arslan**(chairmen), Adnan **Mert**(secretary), Ragıp **Bora**, Mahmut **Topcu**, Niyazi **Arslantaş**, Ziya **Akkaş**, Celal **Kocaoğlu**(Founder memebers). Later years they have orginized various compositons through out Turkey such as pre-dinner,after dinner & long drink cocktails.



## PROCESS of MAKING A FINE BRANDY

1-) The first step in making fine brandies is to allow the fruit juice (*typically grape*) to ferment. This usually means placing the juice, or must as it is known in the distilling trade, in a large vat at 68-77°F (20-25°C) & leaving it for five days. During this period, natural yeast present in the distillery environment will ferment the sugar present in the must into alcohol & carbon dioxide. The white wine grapes used for most fine brandy usually ferment to an alcohol content of around 10%.

2-) Fine brandies are always made in small batches using pot stills. A pot still is simply a large pot, usually made out of copper, with a bulbous top.

3-) The pot still is heated to the point where the fermented liquid reaches the boiling point of alcohol. The alcohol vapors, which contain a large amount of water vapor, rise in the still into the bulbous top.

4-) The vapors are funneled from the pot still through a bent pipe to a condenser where the vapors are chilled, condensing the vapors back to a liquid with a much higher alcohol content. The purpose of the bulbous top & bent pipe is to allow undesirable compounds to condense & fall back into the still. Thus, these elements do not end up in the final product.



5-) Most fine brandy makers double distill their brandy, meaning they concentrate the alcohol twice. It takes about 9 gal (34 Ltr.) of wine to make 1 gal (3.8 Ltr.) of brandy. After the first distillation, which takes about eight hours, 3,500 gal (13,249 Ltr.) of wine have been converted to about 1,200 gal (4,542 Ltr.) of concentrated liquid (**not yet brandy**) with an alcohol content of 26-32%. The French limit the second distillation (*la bonne chauffe*) to batches of 660 gal (2,498 Ltr.). The product of the second distillation has an alcohol content of around 72%. The higher the alcohol content the more neutral (*tasteless*) the brandy will be. The lower the alcohol content, the more of the underlying flavors will remain in the brandy, but there is a much greater chance that off flavors will also make their way into the final product.

6-) The brandy is not yet ready to drink after the second distillation. It must first be placed in oak casks & allowed to age, an important step in the production process. Most brandy consumed today, even fine brandy, is less than six years old. However, some fine brandies are more than 50 years old. As the brandy ages, it absorbs flavors from the oak while its own structure softens, becoming less astringent. Through evaporation, brandy will lose about 1% of its alcohol per year for the first 50 years or so it is "**on oak.**"

7-) Fine brandy can be ready for bottling after two years, some after six years, & some not for decades. Some French cognacs are alleged to be from the time of Napoleon. However, these claims are unlikely to be true. A ploy used by the cognac makers is to continually remove 90% of the cognac from an old barrel & then refill it with younger brandy. It does not take many repetitions of this tactic to dilute any trace of the Napoleonic-age brandy.

8-) Fine brandies are usually blended from many different barrels over a number of vintages. Some cognacs can contain brandy from up to a 100 different barrels. Because most brandies have not spent 50 years in the barrel, which would naturally reduce their alcohol contents to the traditional 40%, the blends are diluted with distilled water until they reach the proper alcohol content. Sugar, to simulate age in young brandies, is added along with a little caramel to obtain a uniform color consistency across the entire production run.

Bu zaman zarfında fıçı gözeneklerinden (*Faßsporen / çeperleri*) oksijen girdiğinden & fıçılardan kaybedilen ~ % 3 alkol buhar olup gökyüzüne gider. Buna da alkolün payı (*Teil des Alkohols*) veya anlamlı olarak;

**(Teil der Engel) MELEKLERİN PAYI**

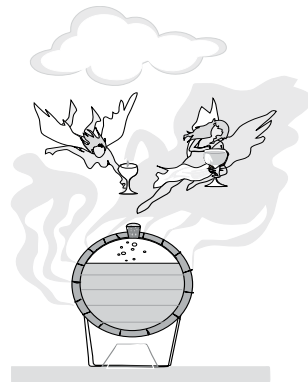



# COGNAC / WEINBRAND / BRANDY / ARMAGNAC / KANYAK (kanıyakan)/ VINJACK ARGUADENTE / GRUSINIAK

*Alembic / Brennblase / imbiç, takdir kazanı*

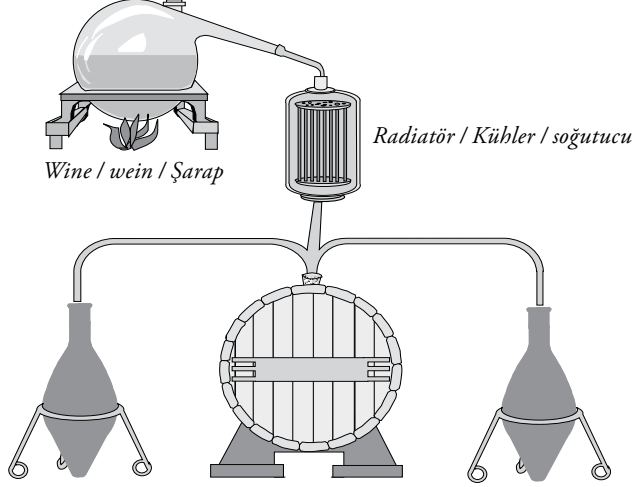

1.damıtma (distillation) /  
1.destillat  
1.Vorlauf / 1.Leap / Premier  
brouilli / 1. koşu, 1.takdir,  
baş mahsul  
(kalitesiz bölüm)

**HERZSTÜCK Goldene Mitt /  
YÜREK PARÇASI, kalp, göbek, baş**  
2.damıtma (distillation) /  
2.destillat  
2.Vorlauf / 2.Leap /  
2.& orta takdir (altın ortası)  
2.koşu (orta) / Deuxime brouilli  
(kaliteli bölüm, en az 2 kere damıtılmış)

3.damıtma (distillation) /  
3.destillat  
3. Vorlauf / 3.Leap /  
3. Son Koşu, 3.takdir,  
son mahsul, kuyruk  
Troisieme brouilli  
(kalitesiz bölüm)

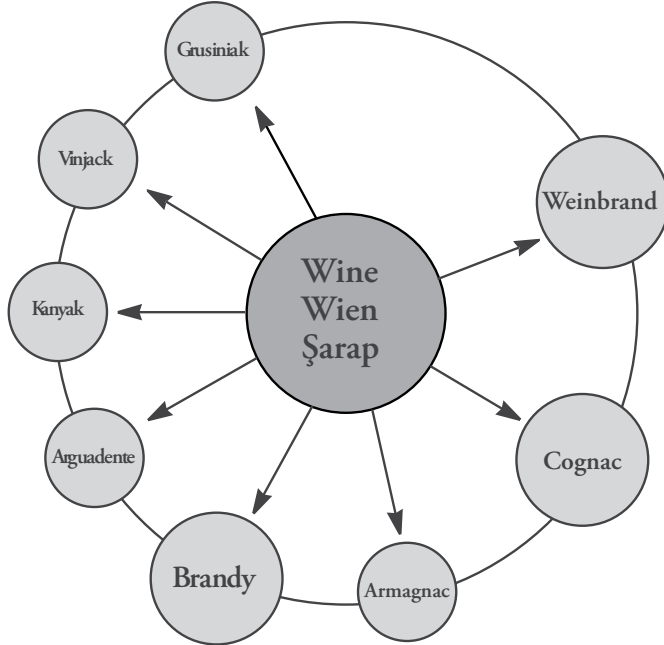

## COCKTAILS/hahnenschwanz/horoz kuyruğu

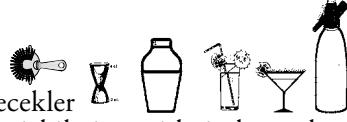

Cocktail Halk dilinde karıştırılarak hazırlanan içecekler için tek bir terim olarak yerleşmiş olsa bile yapılan içkilerin çeşitlerinden sadece birisidir. Bazı içkiler bir kaç içki çeşidine (*grubuna/kategorisine*) dahil edilebilir. Bu isimler ilk defa 1806 The Balance da değinilmiştir, uzman kişi (*barkeeper-bartender-barsupervisor-barmaid-barman*) bundan alkolü, hayalgücü yüklü, bileşimine göre günün farklı zamanlarında severek içilen içkileri anlar. Shaker (sh.), mixglass veya direct bardakta hazırlanırlar & değişik şekillerde dekore edilirler. Bu cocktail'ler dry (*sek/sec/trocken/secco*), medium (*dömisek*), & sweet şekillerine ayrılırlar. Meyve suları, şeker, şurup, cream - crème likörü veya krem şanti (*cream/crème/crema/rahm*), yumurta gibi malzemeleri içine alan tüm cocktail'ler shaker ile hazırlanmalıdır.

Malzemeler sıvı ise mixglass içinde karıştırmak yeterlidir. Cocktail'ler için gerçek ölçü 5 cl. (50 g) ~ 6 cl. (60 g)dır.

şeker şurubu yerine grenadine veya curaçao kullanılabilir. günümüzde cocktail yarışmaları 3kategoride (dalda /grup'ta) yapılır. 1) Pré dinner/before dinner/yemek öncesi/, 2) After dinner /yemek sonrası, 3) Long drink /uzun içkiler/lange trink.

## FIZZES / fıstırlar

long drinks

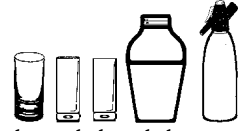

### mise en place / vorbereitung / ön hazırlık :

Kesilmiş bir limonun suyunu bardak ağzında (*rand*) gezdirerek bardak ağzını nemlendiriniz & toz şeker üzerinde hafifçe gezdirip şekerleyiniz. veya şekeriz Amerikanın ünlü kokteyllerindendir. İsmi içkiye sıkılan basınçlı su veya sodadan çıkan fıstırtıdan alınmıştır. Fixes & collinslere benzerler.

Temel reçete /recipe/rezept/recette: Bol miktarda ufak buz parçalarını shaker'a (sh.) koyunuz. Reçeteye göre şeker veya şeker şurup, meyve suyu & alkol ilave ediniz. Bir müddet kuvvetlice çalkalayıp 1 fizz bardağına süzünüz & biraz soda ilave ediniz. (siphon) Gerçek Fizz'ler yumurta akıyla hazırlanırlar.

servis : 1 pipette (1 straw - 1 strohhalm-trinkhalm-chaumeau-paille)

## COLLINS

long drinks



Fizz'ler, fix'ler & sling'ler ile benzer olup bu yüzyılın serinletici içkisidir. Hazırlanışı aynen "fizz'ler" gibi olup bardak ağzları şekeriz servis edilir. long drink bardağında hazırlanıp iyice karıştırılır, soda ilave edilir,1 pipette (1 straw - 1 strohhalm) Collins'ler sadece Hollanda gin'i ile hazırlanırdı, artık cognac, vodka, whiskey, rum vb. ile de hazırlanmaktadır.Shaker (sh.), mixer & direkt bardakta hazırlanabilir.

## SOURS / ekşiler

classic cocktails , medium coctails

long drinks ,fancy drinks



İsmi içkiye tat veren limon suyundan gelmektedir. Cin (*Gin/Genièvre/ginebra/cenevre*) ile hazırlandıklarında bu içkiler koyu Fizz'ler olarak geçerler oysa geçmişte yalnız Whiskey ile hazırlanırlardı. Mise en place : Kesilmiş bir limonun suyunu gezdirerek bardak ağzını (rand) nemlendiriniz & toz şeker üzerinde hafifçe gezdirip şekerleyiniz/veya şekeriz.

Temel reçete : Yeterli miktarda ufak buz parçalarını shaker'a (sh.) koyunuz. 1/2 limonun suyu, 2 bar k. şeker & 5 cl (50 g) alkol (*whisky, cognac, brandy, gin, rum, calvados v.s.*) ilave ediniz. 1 müddet kuvvetlice çalkalayınız. 1 uzun tumbler (long drink) bardağına süzünüz & 2 kokteyl kirazı, 1 rondela (tranch) portakal ile dekore ediniz, biraz soda ilave ediniz. (siphon)

servis : 1 pipette (*straw - strohhalm*) & 1 kokteyl kaşığı

### FLIPS / Çabuk canlandırıcı

Yumurta sarısı ile olan kokteyller

Öğleden önce & çay saatinde

Temel reçete : 2-3 buz parçasını shaker'a (sh.) koyunuz. 1 yumurta sarısı, 1-2 bar k. şeker 5 cl (50 g.) tercih edilen alkolü ilave ediniz. Hepsini kuvvetlice & aynı derecede iyice çalkalayınız. 1 flip bardağına süzünüz & üzerine muscat (*nutmeg - hind cevizi*) tozu serpiniz. Enerjik içkiler olup Egg Nogs'lara benzerler. Kuvvet vericidir.

servis : 1 pipette (*straw - strohhalm*)

before lunch/ öğleden evvel cocktail  
long drinks ,fancy drinks



### COOLERS / serinleticiler

Temel reçete : Yeterli miktarda ufak buz parçalarını (*cracked ice*) shaker'a (sh.) koyunuz. 2-3 bar k. şeker (*veya şurup*), 1/2 limonun suyu & 5 cl. (50 g.)

alkol (*whisky, gin, rum, cognac, arrak v.s.*) ilave ediniz. Kuvvetlice çalkalayıp 1 tumbler (long drink) bardağına süzünüz & Ginger ale (*zencefilli gazoz*) ile doldurunuz (*veya cola*) susuzluğu gideren/Durstlöscher sulandırılmış içkidir. dekor/ garnish meyve parçaları.

servis : 1 pipette (*straw - strohhalm*)

Long drinks



### EGG - NOGS

Sütten veya yumurta ile yapılan kokteyller

Çırpılmış yumurta ile şeker & süttten yapılan bir içecek, bunlara whisky katılarak meydana gelen içki. Temel reçete : 3-4 buz parçasını shaker'a (sh.) koyunuz. 1 bütün yumurta, 2 bar k. şeker & 5 cl. (50. g) alkol (*cognac, rum, brandy, whisky vs.*) ilave ediniz. Süt ile tamamlayıp kuvvetlice çalkalayınız & special bardağa süzünüz. Üzerine muscat (*nutmeg - hint cevizi tozu*) serpiniz. Sıcak veya soğuk olarak canlılık veren içkidir.

servis : 1 pipette (*straw - strohhalm*)

fancy drinks



### DAISIES / papatyalar

Temel reçete: Ufak buz parçalarını shaker'a (sh.) veya mixer'e koyunuz. 1/2 limonun suyu, 2,5 cl. (25 g.) grenadine sirop (*granate syrup - nar şurubu*), 5 cl. (50 g.) alkol (*whisky, rum, cognac, gin, Cherry Brandy "likör", Peach Brandy "likör" vs.*) ilave ediniz. Kuvvetlice çalkalayıp 1 şampanya kadehine süzünüz. 3-4 kokteyl kirazı & nane yaprakları ile dekore (*garnish*) ediniz. soda (siphon) bayan içeceğidir.

servis: 1 pipette (*straws - strohhalm*) & 1 ufak kokteyl kaşığı,

long drinks ,lady drinks



## COBLERS

long drinks



Temeli sherry & Porto'ya dayanır. şarap, şeker & meyvelerden yapılan içkiler bayanlar için special içki Temel reçete : önceden soğutulmuş cobbler bardağında direkt hazırlanır. 2/3 sini ince bir şekilde kırılmış buz ile doldurunuz, değişik kuvvetli kokulu meyvelerle dekore ediniz & 5 cl. (50 g) Cobbler alkolünü (sherry, porto, brandy, champagne vs.) ilave ediniz.  
servis/service : 1 pipette (strow/strohhalm/trinkhalm/chalumeau/paille) & 1 küçük kokteyl kaşığı, rondela (tranche) portakal.

## TÜRK KAHVESİ / Turkish coffee / türkisher Kaffée - mocco

Orta şekerli kahve / metrios : Önce 1 ölçü (1 türk kahve fincanı) soğuk su, cezve'ye konulur. her fincan için 1 tatlı kaşığı (1 dessert spoon/löffel) kahve & şeker konulup kısık ateşte tatlı kaşığı ile (dessert spoon/löffel) karıştırılarak köpürünceye kadar kahve pişirilip soğumadan servis yapılır. (orijinali osmanlılarda / othomanikos / ottoman mangal'da "barbecue/Kohlenbecken/braizer" odun kömürü ateşi ile cezve'de kahve pişirilirdi. Halen bu osmanlı usulunde kahve pişiren vardır.)  
Kahvenin (telves, delves / kaffeesatz / coffeegrounds) telve'sini içmeyiniz.  
servis / service : Bir bardak su & alt tabak.

Kahve : (coffee / kaffee / café / kahwa / gayves / cahoa) kelimesi dünyaya Türkler'den yayılmıştır.

Cezve : (for making Turkish coffee, kahve / kleines Stielgefäß zur zu  
Bereitung von türkischer kaffee, kahve, kaife)

Fincan : (tasse / cup / flincani)

Mangal : (braizer/barbecue/kohlenbecken)

Mangal kömürü : (odun kömürü/charcoal/holzkohle)

Kahve köpüğü : (kafes kaymaki / coffee cream / kaffe schaum)

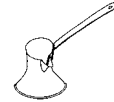

## IRISH COFFEE / İrlanda kahvesi/café İrlandés/eire coffee

Irish Coffee orjinal kadehinde bir jigger (measure / maß / ölçek) 3-4 cl. (30-40 g.) Irish whiskey ısıtınız & bardağı devamlı döndürerek yakınız. orjinal ocağında/rechaud/reşo/ısıtıcı (kadehi devamlı döndürünüz ki patlamasın). Hemen şekeri önceden konulmuş & karıştırılmış sıcak şekerli kahve ile doldurunuz (1 cm kadehin altında). Krem şantili (cream/sahne/crème/crema/Rahm) 1 bar kaşığını ters olarak kadehin üstünde tutunuz & krem şantiyi içine öyle dökünüz ki kahve & krem şanti birbirine karışmasın & karıştırmayınız. (krem şanti siphon ile daha rahat hazırlayabilirsiniz) üzerine rendelenmiş bitter cokolata serpiniz.  
servis: 1 pipette (strawstrohhalm) 1 kokteyl kaşığı & 1 alt tabak.



## FRENCH COFFEE / Fransız kahvesi

Hazırlanışı aynen Irish Coffee gibi olup, sadece whisky yerine bir **jigger** (measure / ölçek) 3 cl. (30 g.) Grand Marnier (portakal & cognac likörü) kullanınız.

## CAPPUCCINO

Directions (Zubereitung): Bir kahve fincanını yarısına kadar Pressopresso (veya cappuccino / Nescafe marka kahve) ile doldurunuz, diğer kalan yarısına sıcak süt ilave ediniz, üzerini bir parça krema & bir tutam Nesquik ile garnitürleyin (üzerine serpiniz).

## ESPRESSO ROYAL

Directions (Zubereitung): 1-Pressopresso'yu (veya Grandos cappuccino / instant coffee, Nescafe Espresso marka kahve) bir ufak fincana bir poşet koyunuz, üzerine Grand Marnier likörü ilave ediniz & krema ile garnitürleyin.

2-Espresso: 1 küçük fincana bir poşet Instant Coffee, (Pressopresso, cappuccino / Nescafe marke kaffee) koyup karıştırarak, sıcak ama kaynamamış su ilave ediniz, şeker isteğe göre sonradan ilave edilir.

## ÇAY (tee / çay / thé / tè / té / tea)

Türkler'in devamlı içtikleri (türkler şerbet, ayran, sahlep, kahveden sonra çay içmeye başlamışlardır.) Türk'lerin teklif edeceği ilk şey çay'dır, çünkü türk çayı barışın sembolüdür, çayın berraklığı, sıcaklığı ise türkün sıcaklığıdır, ateş kırmızısı laleler, bayrağın kırmızısı & çayın kırmızısı türkün kanı olup türkün ta kendisidir.



after dinner drinks



## GROGS

Sıcaksu, şeker, güzel kokulu bitkiler & istenilen alkol'dan oluşan içkidir.

Bir grog kadehi içine 1 cam kaşığı koyunuz 2-3 bar k. şeker. 4-5 cl. (40-50 g) alkol (rum, gin, cognac, whisky, Arrak vs.) ilave ediniz. 1/2 limonun suyunu koyunuz & kadehi kaynar su ile doldurunuz. 1 dilim (tranch) & 1 büyük limon kabuğu ile dekore ediniz. Karanfil, tarçın. İsmi Amiral E.Vernon Alias Grog'dan gelir. 1730'larda okyanusta gemileri seyir halinde iken hava soğuk olduğundan suyu kaynatarak içine rum & şeker koyup karıştırmışlar böylece leziz bir içki bulunmuş. servis : 1 cam grog kaşığı & alt tabak

## APÉRITIFS / aperatifler/aperitivo

Yemekten önce içilebilen içkiler / mide açıcı

Keskin sek (dry/trocken/sec/secco) kokteyller: Martini dry, Gibson, Manhattan, Kir (1 cl. crème de cassis liqueur “red currants - Schwarzer Johannisbeer”, 10 cl. sek şarap)

Kir Royal (1 cl. Crème de cassis “likör”, 10 cl. sek (dry/trocken/sec/secco)

Akdeniz ülkelerinin sek şarapları & Aperatif şarapları : Porto, Sherry (Jerez - Xèrès), Samos, Marsala, Maderia (Madère), Malaga vs. Aperatif içkiler : Alkollü olanlar - vermouth, Amer Picon (bitter), Campari soda (bitter), rakı, ouzo, Pernod, şampanya (sek veya portakal suyu ile); alkolsüz olanlar - meyve suları.

pre Dinner/Before Dinner  
Drinks



## PRÉ-DINNER / before dinner drinks



short drinks  
fancy drinks



Pré Dinner Drinks (yemekten önce alınan içki) short drink kategorisine dahil olan Cocktail'lerdir. Yemekten önce alınan kısa içkilerin mideyi rahatsız etmemeleri için, alkol dereceleri az olmaları gerekir. Bu cocktaillerin yapımında en çok; Cin, Votka, Vermouth, Cherry, Sekt, Portwein, Campari, Martini gibi içkiler kullanılır. Yemekten önce alınan içkilerde en fazla (maximum) 2 cl. şeker şurup veya 2 cl. likör kullanılabilir. Pre-Dinner Drinks International ölçülere göre tamamı 7 cl. olan bir cocktail çeşididir. Yemekten önce alınan içkilerde, After Dinner & Long Drink gibi en fazla (maximum) 5 maddeden oluşur. Yemekten önce alınan içkiler çoğunlukla az ya da hiç dekorsuz (non garnish) olarak servis edilir. Dekorasyon (garnish) içkideki maddeye göre dizaynlanır.

## AFTER DINNERS

Yemekten sonra mideyi rahatlatmak & yemeği hazmettirmek için alınan içkilerdir. Bunların hazırlanmasında whisky, cognac & likör (liqueur) çeşitleri kullanılır. Yardımcı malzeme olarak ise; süt, krema, yumurta, kahve, meyve şurupları gibi ürünler tercih edilir. En fazla 5 madde kullanılır & 7 cl. olmalıdır.

short drinks



## LONG DRINKS / uzun içkiler / lange trinks

Long-Drink uzun içki olarak nitelenen bu kokteyl çeşidinin barlarda çok büyük anlamı vardır. Bu kategoriye giren long drinks çeşitleri; Highballs, Fizzes, Punches, Collins, Flips, Cobblers, gibi içkiler hemen hemen her türlü zamanda içilebilir. Zaman olarak, öğle zamanlarında, öğleden sonra kahve & pasta aralarında, dans partilerinde, havuz başında zevkle içilen bir içki çeşididir. Bütün dünyada Long-Drinks 5 çeşit maddeden en fazla (maximum) 8 cl. alkol & yardımcı maddelerle birlikte en fazla 14 cl. ile 28 cl. arasında hazırlanan bir karışımdan oluşur. long drink cocktail miktarlarının üzerinde hazırlanan içkiler için kullanılan bir terimdir.

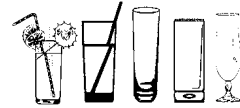

## FANCIES / hayal gücü / fantisie



Bütün Dünya barlarında çeşitli içki kombinasyonları kullanılarak hazırlanan bir cocktail'dir. Pre dinner & After dinner'larda olduğu gibi Madde & alkol ölçüsü gibi sınırlamalar yoktur. Yaklaşık olarak 30 gruba ayrılır; barmenler (barsupervisors - barkeepers) fancy drink'leri hazırlarken yaratıcılığını kullanarak içkiyi uygun dekorlarla süsler & böylece cocktail'de bir fantezi yaratır. Cocktail içinde 5 den fazla madde kullanırsa fancy drinks olarak adlandırılırlar. Çok anlamlı bu fantezi içkileri belirli bir gruba sokmak zordur & belirli bir hazırlanış düzeni bulunmaz. Hayali (fantastik) veya şahıs isimleri verilir.

## FIXES

Direct bardakta hazırlanan, ölçü ile kullanılan içkidir. Az suda eritilmiş şeker & limon suyu ile istenilen alkolün eklenmesi ile hazırlanır, küçük parçalara ayrılmış buz, dekor (garnish) olarak turunç & meyve dilimleri kullanılır.

## EXOTICS / tropical drinks



Bol renkli Güney Amerika içkisi olup, alkollü yada alkolsüz hazırlanır. Seçilmiş meyvelerle (ananas, coconut, pampelmuse/greyfurt v.b.) hazırlanır. 2 pipette (2 straws- 2 strohhalm) mise an place: meyveler önceden soğutulur/mevye kabı önceden soğutucuda soğutulur.

pineapple /ananas tranche / ananas kesme:



## CRUSTAS



Mise en place / ön hazırlık : Kesilmiş bir limonun suyu gezdirilerek bardak ağzı (rand) nemlendirilir & toz şeker üzerinde hafifçe gezdirilerek şekerlenir. Büyüleyici, yemek sonrası içeceklerindedir. Crustas istenilen meyve özleri, likörler (liqueurs), meyve suları, angostura vs. ile shaker'da (sh.) çalkalanır & çoğunlukla limon veya portakal kabukları ile süslenip servis edilir.



## CHAMPAGNE COCKTAILS

Temel alkol veya likörlerle (liqueurs) karıştırılan champagne & köpüklü şarap (sparklings wine, sekt) hazırlanan içkilerdir. Birçok durum için uygun karışımdır. Esasen sadece portakal likörü (liqueur) veya cognac ile hazırlanırlar.



## CUPS / bowls



Köpüklü veya beyaz şaraplar, bu her zamana uygun içeceğin temelini oluşturlar. İsteğe göre oranı artırılabilen meyve özleri, şuruplar, likörler (liqueurs) şeker, taze meyveler (yalnız limon olmamalıdır.) vs. karıştırılarak, istendiğinde gül yaprakları ile süslenebilirler. İçkiler önceden hazırlanarak soğutulur & diğer malzemeler servis yapılmadan hemen önce karıştırılırlar. En son soda ilave edilebilir. Tipik bir eğlence parti içeceğidir. (party drinks)

## after dinner drinks



## FRAPPÉS / glacials / glacés / buzular

Fransızcadan gelen buzla soğutulmuş çeşidi, canlılık verici, hafif, yemek sonrası içkilerdendir. İstenilen bir likör (liqueur) ezilmiş buz ile servis edilir. Şuruplar da kullanılabilir. İtalya'da frappes deyince genellikle mixerde, parçalanmış buzla (cracked ice) karıştırılmış temeli süt veya kahveye dayanan alkollü veya alkolsüz içkilerdir.

Servis: 2 küçük pipette (2 small straws, 2 kleine strohhalm)

## long drinks



## HIGHBALLS / yükselen baloncuklar

Susuzluğu giderici isteğe bağlı olan büyük içkilerdir. buz parçaları, limon, istenilen bir alkol türü & asitli bir içecekten (cola, ginger ale "zencefilli gazoz" vb.) ismi bardağın içinde oluşan gaz/asit kabarcıklarının yükselmesinden gelmektedir.

## JULEPS / Mint-juleps

Naneli likörleri (liqueurs) & bardağa doğranmış taze nane yaprakları ile (ismi buradan gelmektedir), şeker şurubu, alkol & oldukça bol buz parçacıkları ile hazırlanıp, taze nane yaprakları (peppermint/pfeffer-minze/menthe (poivrée)/menta (piperita) / menta, hierbabuena) ile süslenirler & içkinin kokusunu/bouquet/aroma/bukett alabilmek için kısaltılmış içki pipetleri (small straw) de eklenir.

## after drinks



## POUSSE CAFÉS / Rainbow cocktails

Bu 6 çeşide kadar varan kat kat renkli mükemmel renk oyunları yaratan içki, yemek sonrası içkilerdendir. Kendi özgül ağırlıkları sayesinde kat kat birbirinden ayrı kalabilen likörler (liqueurs), meyve özleri veya şuruplardan oluşurlar. Ölçü aleti olmadığından şu pratik kural geçerlidir: Şekeri ne kadar çok veya alkolü ne kadar azsa, ürün o kadar ağırdır. Ayrı ayrı tabakalar ağır ürünün üzerine hafif ürünün gelmesi şeklinde dikkatlice doğrudan bardağa süzülür, arkasından bir öncekinin yüzeyinin altına bir bar kaşığı veya çay kaşığı yardımıyla diğer ürün dikkatlice & yavaş yavaş dökülür, Bu kreasyonlar, renk oyunları belirsiz bir şekilde kat kat olurlar.



## MISTS / buğulu, bulanık

Doğrudan bardakta hazırlanan parçalanmış buz, alkol & limon kabuğundan oluşan ferahlatıcı içkilerdir. İsmi bardağın buğulanmasından alır.



## PICK ME UPS/beni güçlendir (sade, sadeler)

Bu içkinin yorgunluğa karşı yeniden kuvvet toplayabilmek için güçlendirici, neşelendirici olarak şakacı anlamda bir ismi vardır.

long drinks



## PUNCHES / beş, 5, five, fünf

Soğuk veya sıcak olabilirler Sanskrit Pantscha'dan olan asıl yapım şekli 5 malzemenin kullanımını öngörmektedir: su, şeker, arrak (palmiye suyundan mamül Brantwein/ Brandy), hoş kokulu bitkiler & limon. Günümüzde sayısız değişiklikler yapılmıştır. Bowle bunlardan sadece birisidir. Tek kişi için soğuk punch'lar genellikle shaker'da (sh.) çalkalanır, sıcaklar ise özel olarak ısıtılır.



welcome / party drinks



## SANGRIA / Sangre

Bu soğuk ispanyol içkisi birçok çeşit meyvelerden & esasen Pamplonada da olmak üzere sert kırmızı şaraptan yapılırdı. İçkinin ismi koyu kırmızı, boğa kanına benzer renginden gelmektedir Sangre/Kan. Bir kaç şekli vardır, hepsinde meyve aromalarının (bouquet/kokusu) iyi olması için meyvelerin yeterli kadar uzun sürede yetiştirilmeleri gereklidir. İri taneli meyveler içkiyle birlikte yenilebilir.

## SANGAREES

Sangria'nın bir modifikasyonudur / alternatifidir & çabuk hazırlanabilir. Genellikle temeli rosé veya beyaz şaraba dayanır, hindistan cevizi de eklenir. Soğuk veya sıcak olarak servis edilebilir.



## RICKEYS

Ferahlık veren büyük içkilerdir, aslında temelleri cin'e (gin) dayanır, collins içkilerine benzerler & genellikle sarmal turuncgil kabukları ile servis edilirler.

long drinks



long drinks



## SLINGS

Sling'ler sadece shaker'de (sh.) hazırlanmalıdır. Su, şeker, dondurma & limondan oluşurlar & bu karışım sert bir brandy ile tamamlanır. Soda & Ginger Ale (zencefilli gazoz) yada aynı şekilde diğer meyve özleri eklendiğinde long drink sayılırlar.

## SPARKLINGS

Hafif, ferahlık verici, bir çok duruma uygun olan bu içkiler taze meyvelerin püreleriyle karıştırılarak köpüklü şaraplar ile renklendirilir & köpürtülür. Alkolsüz şekli ise Ginger Ale (zencefilli gazoz), tonic vb. leri ile karıştırıldığında elde edilir.

## TODDIES

Esasen sadece soğuk günler için sıcak olarak yapılırlar. Groglar veya punch'lardan farklı olarak Toddies içkilerinde bazen krema, tereyağı vb. malzemeler de kullanılır. Soğuk içecek olarak angostura bitter & limon suyu ile hazırlanabilir & değişik bir içecek olur.

sıcak / hot / heiß



soğuk / cold / kalt



## ZOMBIES

Alkol oranı yüksek olan büyük/long içkilerdir. Shaker'da (sh.) bol buz parçaları, meyve suyu & bol beyaz & kahverengi rum karıştırılıp hazırlanışından sonra ayrıca 75 °C lik biraz rum içkinin üzerine dökülür. içki isteğe & kişinin zevkine göre taze meyvelerle süslenir.

long drinks



## HOT DRINKS

Sıcak & ılık içecekler için genel/general bir kavramdır.



## SOFT DRINKS

Alkolsüz içkiler için genel/general bir kavramdır.



## ON THE ROCKS / buz üstü / auf Eis

Belirli bir çeşit oluşturmazlar. Sade içkiler (pure/pur) veya kokteyller 3-4 adet buz ile sunulur. İstek üzerine süsleme (garnish) yapılır.

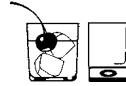

## SHORT DRINKS

Küçük/kısa içkiler 6 cl./60 g.'a kadar genel/general bir kavramdır, & içkiyi hafifleten herhangi bir içki eklenmez.



## SMASHES Collins & Juleps arası / Zwischen Collins & Juleps



Juleps (mint-juleps) benzeri, direkt bardağında hazırlanır, taze nane yaprakları & parçalanmış buz (cracked ice) parçalarından ismi gelir. Dekor (garnish) tranch limon veya portakal, nane yaprakları. Servis: 2 kısa pipette (2 small straws/2 klein strohhalm)

## SYRUPS / Sirops / Şuruplar

Esası turunçgil (zitrusfrüchte) & fundagil (Gestrüpp - heidekraut- fonda) meyvelerinden oluşur 4-5 gün Rum (Rom - Rhum - Ron) içinde bekletilmiş ferahlatıcı yemek sonrası içkilerdir. Günümüzde daha başka meyve özleri, meyveler & hoş kokulu bitkilerde kullanılmaktadır. Buzdolabında korunup servis' den önce süzgeçten geçirilir. Dekor (garnish) taze meyveler.



## SWIZZLES

Swizz'ler belirli bir kategori (category/kategorie) çizgisi oluşturmaz; Direkt bardakta hazırlanırlar, sticker/karıştırma çubuğu (swizzle-stick) ile hafifçe karıştırılır.

## MESSAGE / MESAJ :

final içkisi nedir?

Hotelinizin à la carte restoranın'da müşteri aperatif içkisini aldıktan sonra ( sırasıyla pré-dinner, after dinner, long drink) horse d'œuvre / çorba / soup / suppe " çorba servisinde içki servisi yapılmaz !. ön yemek , ara sıcak, ana menu, dessert / tatlı' dan sonra çay & kahve yanında bilinen klasik cogniac veya likör sunulur. Müşteriye sunulacak herşey sunulmuştur. Sunulacak hiçbirşey kalmamıştır. Buna rağmen sunulacak son bir final içkisi vardır.

## **BU FİNAL İÇKİSİNİN ADI NEDİR ?**

Info: +90. 533. 321 83 28  
adnanmert16@hotmail.com



COCKTAILS / Hahnenschwanz / Horoz kuyruğu

Unter diesem Namen erstmalig 1806 in The Blanc erwähnt, versteht der Fachmann (Barmaid-Barman) jene alkoholhaltigen, fantasievollen Drinks die-je nach Zusammensetzung zu verschiedenen Tageszeiten gern getrunken werden. Sie werden im Shaker (sh.), Mixglas oder direkt im Glas zubereitet & vielseitig garniert (*garnish*). Basismenge: 60 ml. Diese Cocktails unterscheidet man dann in: Dry, Medium & Sweet. Cocktails mit zucker, sirup, Fruftsäften, Eier & sahn (*cream/krem şanti/çrémel/crema/Rahm*) werden mit dem Shaker (sh.) zubereitet. Falls der inhalt flüssig ist, genügt es, es in einem Mixglass (mg.) zu mixen. Die richtige Menge für Cocktails ist 5 cl. (50 g.) - 6 cl. (60 g.)

(Anstatt Zucker sirup kann man auch Grenadine oder Çuraçao benutzen.) Heutzutage werden die Cocktailwettbewerbe in 3 kategorien gemacht 1- Pre-Dinners (*before dinners*) 2- After dinners (*nach dem Essen*) 3- long drinks (*lange trinks / uzun içkiler*)

FIZZES / fışirtılar

Gehören zu den bekanntesten American Drinks. Der Name rührt von dem zischenenden Ton, welcher durch das Syphonwasser beim Aufspritzen der Drinks erzeugt wird. Verwandt mit den Sours, Fixes & Collins werden die Fizzes im Shaker (sh.) kräftig bis zu dessen Beschlagen geschüttelt. Ein echter Fizz wird mit Eiweiß zubereitet.

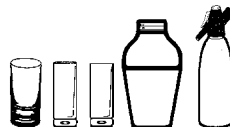
long drinksCOLLINS

Mit Fizzes, Fixes & Slings verwandte, erfrischende Drinks. anfang dieses Jahrhunderts wurden Collins nur mit holländischem Gin zubereitet, mittlerweile auch mit Cognac, Wodka, Whisky, Rum u.ä. Er wird im Shaker (sh.) oder auch direkt im Glas mit Eiswürfel & soda gemixt

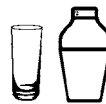
long drinksSOURS / ekşiler

Wegen des geschmacksprägenden Zitronensaftanteils so genannt. Sofern sie mit Gin zubereitet werden, können diese Drinks als konzen-trierte Fizzes gelten, einst wurden sie allerdings nur mit Whiskey zubereitet. Servis/service: 1 pipette (straw/strohalm/trinkhalm/ chalumeau/paille)

classic cocktails, medium cocktails  
long drinks, fancy drinksFLIPS / çabuk canlandırıcı

Schnell aufrüttelnde - daher der name - sehr energiereiche, mit den Egg-Nogs verwandte, leicht verdauliche Getränke, bestehend aus frischem Eigelb, Zucker, ggf. Sahne, Südwein & /oder Destillaten. Im Shaker (sh.) mit Eis/ice ganz kurz geschüttelt, werden diese drinks mit einer Spur geriebener Muskatnuß (*nutmeg*-

before lunch / öğleden evvel cocktail  
long drinks, fancy drinks

*muscat-hint cevizi*) gewürzt & unmittelbar nach der Zubereitung getrunken. Flips am frühen Vormittag wirken aufmunternd & stärkend. Durstlöscher drink/susuzluk giderici servis/service: 1 pipette (*straw/strohalm/ trinkhalm/chalumeau/paille*)

long drinks

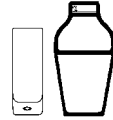

### COOLERS / serinleticiler

Eiskalte, durststillende Long drinks. Aus Zitronensaft, Spirituosen & reichlich Ginger Ale oder anderen kohlen säurehaltigen Flüssigkeiten bestehend, werden sie im shaker (sh.) oder direkt im Glas-je nach Zusammensetzung mit viel zerkleinertem Eis zubereitet, mit Ginger Ale aufgefüllt & ggf, mit obstwürfeln garniert.  
servis/service : 1 pipette (*straw/strohalm/trinkhalm/chalumeau/paille*)

fancy drinks



### EGG - NOGS

Cocktails, die mit Milch oder mit Eier gemacht werden:  
Resept/reçete: 3-4 Eis stücke/würfel in einem Shaker (sh.) geben, Ein ganzes Ei, 2 bar löffel Zucker & 5 cl. (50 g.) Alcohol (Cognac, Rum, Brandy, Whisky u.s.w.) & ein bißchen Milch zugeben & kräftig mixen. Sieben Sie die Mischung in einem Special Glas. Oben- drauf kann man mit Muskat (*Muscat/Nutmeg*) garnieren. Wird heiß oder kalt getrunken. Erzeugt Heiterkeit.  
Servis/service:1 Strohhalm (*1 straw-1 pipette-chalumeau*)

long drinks ,lady drinks



### DAISIES / papatyalar

Gelten als damen long drinks & bestehen aus einer beliebigen im shaker geschütelten Spirituose mit 1/2 Lime-oder Zitronensaft & meistens Grenadine-Sirup. Die Gläser werden mit Sodawasser aufgefüllt & mit Saisonobst & Minzeblättern garniert.

service : 1 pipette (*straw - strohalm*) & 1 kleiner cocktail löffel

long drinks



### COBLERS

Auf Sherry oder Porto Grundlage basierend, sind diese garnierten köstlichen Longdrinks für gesellige Abende geeignet. Sie werden aus dem bevorzugten Basisprodukt mit zerschlagenem Eis zubereitet & mit Saisonfrüchten garniert. Mit Likören (liqueurs) & Destillaten lassen sie sich gut verbinden & werden direkt im vorgekühlten Glas zubereitet.

## TÜRK KAHVESİ / turkish coffee / türkisher Kaffée - mocca

Orta şekerli kahve / medium sugar Turkish coffee / metrios / mit mittel zucker : 1 kaffee tasse (*Türkische Kaffeetasse*) kaltes Wasser gibt man in ein kleines cezve (*stielgefäß / cezves*) Für jede tasse ein kaffee- löffel Kaffee & zucker geben, & unter ständigem rühren den kaffee zum kochen bringen. Heiß servieren. bitte, kaffeesatz (*telve / telves / coffeegrounds*) nicht trinken. (*Bei den alten Ottoman/Osmanlı / Othomanikos kochte man den kaffee mit der cezve, mangalda "auf kohlenbecken" im holzkohlen feuer. Auch heute noch gibt es diese tradition.*)

kahve : (*coffee / kaffee / café / cafes / kahwa / cahoa / kaves / gayfes*) Dieser name hat sich von den Türken (ottomanen/osmanlı / othomanikos) ausgebreitet.

cezve : (for making Turkish coffee, kahve / kleines Stielgefäß zur zu bereitung von türkischen kaffee, kahve, kaife)

fincan : (tasse / cup / filincani)

mangal : (braizer/barbecue/kohlenbecken)

mangal kömürü : (odun kömürü/charcoal/holzkohle)

kahve köpüğü : (kafes kaymaki /coffee cream /kaffee schaum.



## IRISH COFFEE / irlanda kahvesi/café irlandés/Eire coffee

Man erhitzt in einem original Irish Coffee Glas 3-4 cl. (30-40 g.) Irish Whiskey indem man das Glas immer dreht./auf original Rechaud/reşo/ısıtıcı Die vorbereitete zucker & kaffee Mischung gießt man bis 1 cm. unter dem Glasrand, Oben drauf gibt man einen umgedrehten bar löffel/spoon Schlagsahne (*cream/crème/crema/rahm/krem şanti*) & garniert (*garnish*) mit geriebenem (*raspel/rende*) Bitter Schokolade/chocolate/çikolata.

Servis/service:1 Message / mesaj : bazı servislerde pipette konulur, neden ?

info.: +90. 533. 321 83 28

## FRENCH COFFEE / fransız kahvesi

Die zubereitung ist gleich wie beim Irish Coffee, Anstatt Whiskey Werwenden Sie 3 cl. (30 g.) Grand Marnier (*orangen & cognac likör/liqueur*)

## CAPPUCCINO

Löslicher Bohnenkaffee (Pressopresso, cappuccino / Instant Coffee / Nescafe marke kaffee) mit Kaffeeweißer & Zucker.

Directions (Zubereitung): Eine Kaffeetasse zur Hälfte mit fertigem Instant Coffee, (Pressopresso, cappuccino / Nescafe marke kaffee) füllen, dann den Rest mit heißer Milch aufgießen, ein Häubchen Sahne draufsetzen & mit einer Prise Nesquik krönen.



## ESPRESSO ROYAL

Directions (Zubereitung): Pressopresso (oder cappuccino / Instant Coffee / Nescafe Espresso marke kaffee) in ein Glas füllen, Grand Marnier Liqueur hinzufügen, mit Schalgsahne garnieren.



## GROGS



Sind Getränke aus heißem Wasser, Zucker, Gewürzen & beliebiger Spirituose, Der Name ist dem Admiral E. Vernon - alias Old Grog zu verdanken der ca. 1730 die Idee hatte, an Bord verfaultes Wasser durch Aufkochen & Zugeben von Rum & Zucker wieder genießbar & wie! - zu machen.



## APÉRITIFS / aperatifler/aperitivo

Magenöffner vor dem Essen aus aromatisierten Weinen (Vermouth, Sherry, Porto etc.) oder Likör, Pflanzenextrakten, Destillaten, Kräutern & deren Mischungen - mit oder ohne kohlenensäurehaltigen weiteren Flüssigkeiten. Diese Drinks werden selten garniert.



short drinks  
fancy drinks



## PRÉ-DINNER / before dinner drinks

Pré Dinner Drinks/vor dem Essen gehören zu den Short Drink kategorien. Da sie den Magen nicht stören sollen, müssen sie mit wenig Alkohol zubereitet werden. Bei diesem Cocktails werden am mei-sten Gin, Votka, Vermouth, Cherry, Sekt, Portwein, Campari, Martini u.s.w., gebraucht. Bei diesen Drinks werden höchstens 2 cl. (20 g.) Zucker sirup oder 2 cl. (20 g.) likör / liqueur benutzt. Nach internationalen maßen (measure/ölçek maß) muß die ganze Mischung 7 cl. (70 g.) sein. Pré Dinner Drinks, wie nach Dinner Drinks (long drinks) bestehen höchstens aus 5 sorten, Sie werden am meisten ohne garnitur (garnisch/decor) serviert. auf Wunsch kann man es auch garnieren (decor/garnisch).

### short drinks



## AFTER DINNERS

Liköre, Magenbitter & alle Drinks, die nach dem Essen serviert werden gekühlt, mit Eis, bei Raumtemperatur, pur/pure, gemixt, warm usw.

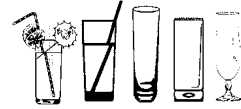

## LONG DRINKS / lange trinks / uzun içkiler

Long Drinks kann man zu jeder Zeit trinken. Zu dieser kategorie gehören Highballs, Fizzes, Punches, Collins, Flips, Cobblers, u.s.w. Man kann Sie Mittag, zur Kaffee-Kuchen Zeit, Tanz parties, oder zur Gartenparties mit Genuß trinken. Auf der ganzen welt werden diese Getränke von 5 sorten maksimal 8 cl. (80 g.) alkohol & verschiedene Materials (sirup - bitter - obstsäfte u.s.w.) maximal bis zu 14 cl. (140 g.) oder 28 cl. (280 g.) vorbereitet. Deswegen heißen diese Getränkemischungen long drinks (lange trinks).

## FANCIES / hayal gücü / fantasie

Gesamtbegriff für Fantasie-Drink, die durch ihre Vielfältigkeit schwer in feste Kategorie einzuordnen sind. Es gibt keine grenze bei den mischungs Material & Alkohol maß (measure / ölçek) wie bei den Pré Dinners oder After Dinners Drinks. Ungefähr gibt es 30 Sorten. Die Barsuparvisors (Barmen - Barmenler - Barkeepers - Barmans) können mit ihren eigenen fantasien und dekorationsideen die Drinks vorbereiten. Daher haben sie den Namen Fancies (Fantasie Drinks). Cocktails, die mehr als 5 Mischung enthalten nennt man Fancies (Fantasie Drinks). Diese Drinks kann man nicht in irgendeine kategorie zählen.



## FIXES

Direkt im Glas zubereitete, mäßig alkoholhaltige Drinks, mit wenig Wasser aufgelöstem Zucker, frischem Zitronensaft, beliebigem Destillat, zerkleinerte (cracked ice) & Zitruscheibe bzw. frischen Obstwürfeln.

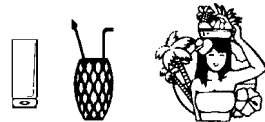

## EXOTICS / tropical cocktails

Diese farbenfrohen Drinks südamerikanischen Ursprungs werden mit oder ohne alkohol direkt in gewählten Früchten wie Ananas, Kokosnuß, Pampulmuse (grapefruit / pamplemousse) etc. zubereitet, garniert (garnish) & mit 2 Trinkhalmen (2 straws, 2 pipette) versehen. Die Fruchthülle sollte vorher im Tiefkühlfach aufbewahrt werden.

pineapple / ananas tranche / ananas kesme:



CRUSTAS

Attraktive After Dinner Drinks mit der typischen Zuckerkruste am Glasrand Dazu Glasrand mit der Öffnung nach unten durch ein Stück Zitrone ziehen & wenige Millimeter tief in Zucker tauchen. Crustas werden mit beliebigen Destillaten, Likören, Obstsäften, Angostura etc. im Shaker (sh.) geschüttelt & meistens mit einer langen Spirale aus Zitronen oder Orangenschale serviert.



CHAMPAGNER COCKTAILS

Drinks für viele Gelegenheiten aus Champagner bzw. Schaumwein, die mit Destillaten & /oder Likören gemixt werden. Ursprünglich nur mit Orangenlikör & Cognac zubereitet.

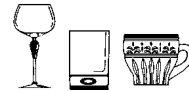

CUPS / bowls

Moussierende bzw. Schaum oder Weißweine stellen die Basis dieser zu jeder Zeit geeigneten Drinks dar. Je nach Geschmack können hochprozentige Destillate, Sirup, Likören, Zucker, frische Früchte (keine Zitrone) etc. beigemischt & ggf. mit Rosenblüten dekoriert (garnisch) werden. Rechtzeitig vorbereitet & gekühlt werden die Zutaten erst kurz vor dem Servieren gemischt. Mineralwasser kann zuletzt hinzugefügt werden. Ein typischer Party Drink.

after dinner drinks

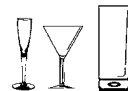

FRAPPES / glacials / buzlar

Auf dem Französischen für im Eis gekühlt sind erfrischende, leichte After Dinner Drinks aus mit einem beliebigen Likör getränkten zerstoßenen Eis, mit 2 kleinen Trinkhalmen (2 small straws, 2 küçük pipette) serviert. Sirupe finden aber auch Verwendung. In Italien versteht man unter Frappés meistens im Mixer mit geschabtem Eis durchgerührte Getränke auf Milch-bzw. Kaffee-Basis mit oder ohne Spirituosen!

long drinks



### HIGHBALLS / yükselen baloncuklar

Beliebte durstlöschende Longdrinks mit Eiswürfein, Zitrone, irgendeiner Spirituose & kohlenensäurehaltiger Flüssigkeit (Cola, Ginger Ale etc.) Der Name rührt vom Emporsteigen den Kohlenensäurebläschen im Glas her. Wird ohne jegliche Garnierung (non garnish/decor) serviert.

### JULEPS / mint - juleps

Werden grundsätzlich mit frischen, im Glas zerdrückten Minzeblättern daher der Name, Zuckersirup, Spirituosen & reichlich zerstoßenem Eis zubereitet, mit frischer Minze (pfeffer-minze/peppermint/menthe (poivrée)/menta (piperita)/menta, hierbabuena/nane) garniert & um das Bukett (bouquet/aroma/kokusu) besser wahrnehmen zu können.



after drinks



### POUSSE CAFÉS / rainbow cocktails

Diese bis zu sechs Sorten übereinander geschichteten prächtigen Farbspieleereien sind After Dinner Drinks, bestehen aus Likören, Destillaten & oder Sirupen, die durch ihr eigenes spezifisches Gewicht voneinander getrennt bleiben. In Ermangelung eines Meßgerätes gilt folgende Faustregel: je mehr Zucker bzw. je weniger Alkohol, um so schwerer das Produkt. Die getrennten Schichten werden direkt im Glas durch vorsichtiges Hinabgleitenlassen des leichteren Produkts auf das schwerere - über den Rücken eines nur mit der Spitze unter die Oberfläche der vorherigen Schicht reichenden Teelöffels gebildet, verspielte Naturen kosten diese Kreationen mittels Trinkhalm (straw, pipette) Schicht für Schicht in beliebiger Reihenfolge.

### MIST / buğulu, bulanık

Direkt im Glas zubereitete erfrischende Getränke mit viel geschabtem Eis, Spirituose & zitronenschale, deren Name vom hervorgerufenen Beschlagen des Glases (also: neblig) stammt.



### PICK ME UPS / canlandırıcılar / beni güçlendir (sade şekli).

Scherzhafte Bezeichnung für kräftigende Muntermacher gegen Kater & um neue Kräfte zu sammeln.

## PUNCHES / beş, 5, five, fünf

Dürfen kalt oder warm sein. Aus dem Sanskrit Pantscha/5 sah die ursprüngliche Herstellungsart die Verwendung von 5 Zutaten vor: Wasser, Zucker, Arrak, Gewürz & Zitrone. Heute gibt es unzählige Abwandlungen die Bowl ist nur eine davon. Kalte Punches für Einzelpersonen werden meistens im Shaker (sh.) geschüttelt; warme extra aufgewärmt. "cold or hot / sıcak veya soğuk"

long drinks



## SANGRIA / sangre

Dieses spanische Kaltgetränk mit vielen Früchten aller Art wurde ursprünglich in Pamplona nur aus schweren Rotweinen hergestellt. Seine tiefrote, stierblutähnliche Farbe gab ihm den Namen sangre / blut. Es gibt etliche Varianten, die alle ein langes Ziehen der Früchte im Wein vorsehen, damit sich das Aroma gut überträgt. Die grob zerkleinerten Früchte kann man mitessen.



welcome / party drinks



## SANGREES

Aus der Sangria abgewandelte, für Einzelpersonen schnell herzustellende Drinks, meistens auf Rosé- bzw. Weißweinsbasis mit Nutmeg (muskatnuß / hint cevizi / (Noix de) muscade / muscat / Noce moscata / Nuez moscada) können heiß oder kalt serviert werden.



## RICKEYS (to refresh / erfrischend / ferahlatıcı)

Erfrischende Long drinks, ursprünglich nur auf Gin (cin/genièvre/cenevre/ginebra)-Basis "temel", mit den Collins eng verwandt. Sie werden häufig mit spiralförmiger Zitruschale serviert.

long drinks



## SLINGS

Werden nur im Shaker (sh.) zubereitet. Unverfälscht bestanden sie aus Wasser, Zucker, Eis & Zitrone, die von einem Branntwein umschlungen wurden. Mit Sodawasser oder Ginger Ale sowie anderen Destillaten werden sie auch als Long drinks geschätzt.

long drinks



## SPARKLINGS / schaumwein / vin mousseux / köpüklü şaraplar

Leichte, erfrischende, für viele Gelegenheiten geeignete Drinks, die durch Verbindung von pürierten frischen Früchten mit Schaumweinen zum Funkeln & Schäumen gebracht werden. Eine alkohol-freie Version wird durch Verwendung von Ginger Ale, Tonic Water u.ä. erreicht.



sıcak / hot / heiß



soğuk / cold / kalt



## TODDIES

Ursprünglich nur als heißes Getränk für kalte Tage geeignet. In Abwandlung zu den Groggs oder punches wird für die Toddies gelegentlich auch cream (sahne / krem şanti / crème fraiche / panna, ceram / Nata, crema) Butter u.ä. mitverwendet. Als Kaltgetränk auch mit Angostura bitter & Zitronensaft zu verändern.

long drinks



## ZOMBIES

Sehr alkoholreiche Long drinks. Nach der im Shaker (sh.) erfolgten Zubereitung mit Fruchtsaft & reichlich weißem & braunem Rum wird zusätzlich noch 75 % Rum auf der Oberfläche verteilt & der Drink, ggf. mit frischen Früchten garniert (garnish) seiner Bestimmung überlassen.

## HOT DRINKS

Ein Ausdruck für warme & lauwarme Getränke (Drinks).



## SOFT DRINKS

Ein Ausdruck für alkoholfreie Getränke (Drinks).



## ON THE ROCKS / buz üstü / auf Eis

Gehören in keine kategorie. Pur Drinks (pure drinks - sade içkiler) oder kokteyls werden mit 3-4 Eis würfeln serviert. Auf wunsch kann man sie garnieren (garnish / decorieren)

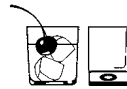

## SHORT DRINKS / kurze trinks / kleine trinks

Wie pfeffermints-juleps, mit Eisbröckeln (zerstockene Eis-cracked ice) & frische pfeffermints (nane yaprakları - peppermint - menthe (poivrée) menta, hierbabuena) blätter, werden direkt im Glas vorbereitet.

Service / servis : 2 kleine strohhalme (2 küçük pipette / 2 small straws)



## SMASHES / Zwischen collins & juleps / collins & juleps arası

Wie pfeffer mints-juleps, mit Eis bröckeln (zerstochene Eis-cracked ice) & frische pfeffermintsblätter. Werden direkt im Glas vorbereitet.

Service / servis : 2 kurze strohhalme (2 small straws / 2 kısa pipette)



## SYRUPS / sirops / şuruplar

Aus zitrusfrüchte & Gestrüpp (fundagil-heidekraut-fonda) entstandene Drinks. Die Fruchtstücke werden 4-5 tage in Rum (Rom - Rhum - Ron) eingelegt. Sind erfrischende nach Mahlzeit Drinks. Heutzutage werden auch verschiedene obstnektars & aromatische pflanzen gebraucht. Wird im kühler aufbewahrt. Wird vor dem service gesiebt & mit frischen obststücken dekoriert.



## SWIZZLES

Gehören nicht zu irgendeine kategorie. Werden direkt im Glas vorbereitet & leicht mit dem sticker gerührt.

## MESSAGE / MESAJ :

final içkisi nedir?

Hotelinizin à la carte restaurantın'da müşteri operatif içkisini aldıktan sonra ( sırasıyla prédinner, after dinner, long drink) horse d'œuvre / çorba / soup / suppe " çorba servisinde içki servisi yapılmaz !. ön yemek , ara sıcak, ana menu, dessert / tatlı' dan sonra çay & kahve yanında bilinen klasik cogniac veya likör sunulur. Müşteriye sunulacak herşey sunulmuştur. Sunulacak hiçbirşey kalmamıştır. Buna rağmen sunulacak son bir final içkisi vardır.

## BU FİNAL İÇKİSİNİN ADI NEDİR ?

Info: +90. 533. 321 83 28  
adnanmert16@hotmail.com





## COCKTAILS



Cocktails are prepared by mixing drinks, and can be made with many different type of ingredients. A few drinks of certain beverages can be grouped or categorised. Those names have been mentioned first time in 1806 in the Balance.

Experience Bar Keeper or Bar Tender can create & understands how to make perfect cocktails by combining different alcohols.

Cocktails are prepared by mixing glass, shaker, or straith in to a long glass and can be decorated with different ingeridients. Those cocktails can be enjoyed through out the day with sweet, dry & medium tests.

The cocktails that prepared with cocktail shaker are fruit juices, sugar, syrup, cream, cream liqueur, or whiped cream, simply mix the liquid ingrediends in the mixglass, instead of grenadine or sugar curaçao can be used.

The real meauser for cocktails are 5cl(50g),6oz.(60g)

Today Cocktail compatitions are in three categories ;  
 1) before dinner, 2) After dinner, 3) Long/Large drinks.

## FIZZES

preparation:

With lemon, moisten the tip of the glass, then cover it lightly with powder sugar, (or without sugar which Americans prefer). The name comes from the noise that fizzy water or soda water makes while poured inside the glass.

Similar to that Fixes & collins.

The Basic recipe; put plenty of small pieces of ice inside the shaker (sh.) as per recipe put some sugar or sugar syrup, fruit juice & extra alcohol, add a little s & after vigorously shaking pour it into the fizz glass, & add a little soda water. (siphon) Real Fizz's are prepared with egg whites.

Service: 1 pipette (1 straw 1)

long drinks

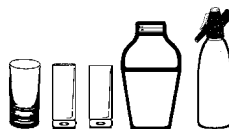

## COLLINS

Fizz, is similar to Fix & sling & this centuries most refreshing drink. Preparation is exactly the same "fizz," part from no sugar on tip of the glass, mix well in long drink glass, stir well & add soda in it, use 1 pipette (1 straw 1 strohhalm) Collins are used to be prepared with only the Netherlands gin, nowadays can be prepared with Collins, cognac, vodka, gin, whisky, rum, & so on. Can be prepared with Shaker (sh), mixer or directly on the glass.

long drinks



## SOURS

The name comes from the lemon water juice. Its called dark fizz if it is prepared with Gin(Gin/ Genièvre/ Ginebra/ Geneva), however dark the Fizz used to be prepared with Whiskey alone.

classic cocktails , medium coctails  
long drinks ,fancy drinks



Mise en place: moisten the top of glass lightly with powdered sugar or no sugar.  
 Basic recipe: put adequate pieces of ice in a shaker (sh.), mix it with 1/2 lemon juice, 2 bar k. sugar & 5 cl (50 g) alcohol (whisky, cognac, brandy, gin, rum, calvados, etc.), vigorously shake & pour it in one long glass tumbler (long drink) & decorated with 2 cocktail cherry, 1 washer (tranch) decorated with orange, add a little soda water(siphon).

Service: 1 pipette (straw ) & 1 cocktail spoon

## FLIPS

Cocktails that prepared with a egg yolg.  
 before lunch & during afternoon tea.

Basic recipe; Put 23 pieces of ice cubes, 1 egg-yolk, 12bar k. sugar, 50cl(50g) required alcohol mix them inside shaker, and shake it vigorously empty it inside flip glass, sprinkle with nutmeg powder, this is a full of energy drink.

Service : 1 pipette (straw )

before lunch/ öğleden evvel cocktail  
long drinks ,fancy drinks



## COOLERS

Basic recipe; Put enough ice cubes inside shaker, mix it with 23bar k. Sugar (or syrup), 1/2 lemon juice, 5cl(50g) alcohol (whisky, gin, rum, cognac, etc.)shake them well,empty it inside a long glass, top it up with Ginger ale or Cola, decorate it with fruit pieces, this drink does help you cool down.

service : 1 pipette (straw )

fancy drinks



## EGG NOGS

This cocktails based on milk & eggs,

Basic ingredients are whiped egg & milk,sugar and whisky.

Basic recipe; Mix, 34 small pieces ice(cracked ice)1 egg, 2 bar k. sugar, 5cl(50g) alcohol (cognac, rum, brandy, wisky, etc.) inside the shaker, top it up with milk, shake them well, pour it over a special glass, sprinkle over with nutmeg.

This drink can be consumed hot or cold. This is a energy drink.

fancy drinks



## DAISIES

Basic recipe: Put small pieces of ice to the shaker (sh) or into the mixer. Mix it with 1/2 lemon juice, 2.5 oz (25 g) grenadine sirop (granate syrup grenadine), 5 cl (50 g.) alcohol (whisky, rum, cognac, gin, Cherry Brandy, Peach Brandy liqueur "liqueur", etc.). Vigorously shake 1 champagne glass. 34 cocktail cherry & decorated with mint leaves (garnish). Add soda water (siphon), this is usully Lady's drink.

Service: 1 pipette (straws) & 1 small cocktail spoon

long drinks ,lady drinks



## COBBLERS

long drinks



Based on the foundation of sherry & Porto' s. Wine, sugar & fruit the basic recipe for a special drink for the ladies: the drinks are chilled in cobbler glass direct. 2/3 of the thin fill with crushed ice in a way that is decorated with different aromatic fruits. & 5 cl (50 g), can add (sherry, porto, brandy, champagne, etc.).

Service/service: 1 pipette (strow/strohalm/trinkhalm/chalumeau/paille) & 1 small cocktail spoon, washer (tranche) orange.

## TURKISH COFFEE / Türkisher Kaffée mocca

Cappuccino coffee/metrios: 1 measure (1 Turkish coffee cup) of cold water to the coffee pot. 1 teaspoon (1 dessert spoon/löffel) coffee & sugar for every cup and cook over low heat stirr it until comes up to a boil . Originally used to be cooked on Ottomans(othomanikos/ottoman) Grill "in barbecue/Kohlenbecken/braizer" charcoal fire. Currently some places still cookes this Ottoman way coffee, Do not drink Coffee (telves, delves/kaffeesatz) grounds left at bottom of the coffee cup . Service/service: coffee cup and A glass of water &.

The word Coffee (kahwa coffee/café/kaffee//gayves/cahoa), was spread over the world from the Turks.

Coffee pot: (for making Turkish coffee, coffee/kleines Stielgefäß zur zu Türkischer Bereitung von kaffee, coffee, kaife)

Coffee cup (tasse/cup/flincani)

Brazil: (braizer/barbecue/kohlenbecken)

Charcoal (charcoal/charcoal/holzkohle)

Coffee mousse: (cage kaymaki/coffee cream/kaffe schaum)

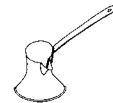

## IRISH COFFEE / irlanda kahvesi/café irlandés/eire coffee



Heat the Irish Coffee in his original jigger (measure/maß/scale) 35 cl (350 g.) Irish whiskey reheat & rotate the mug continuously( so that glass mug does not explode). Immediately add stirred sweetened coffee with sugar (1 cm ). 1 bar of whipped cream (cream/scene/creme/crema/Rahm) put in mug in a way that shoul'n't mix with whisky-by using other side of the spoon- Cream separates into it , Once that coffee & whipped cream next to each other (you can prepare it more easy with whipped cream siphon) sprinkle with grated dark chocolate .

Service: 1 pipette (straw) 1 1alt cocktail spoon & cup/mug.

## FRENCH COFFEE/ Fransız kahvesi

Preparation is just like the Irish Coffee instead of a whisky,( jigger, measure/maß/ scale) 3 cl (30 g).use Grand Marnier (Orange & cognac liqueur).

## CAPPUCCINO

Preparation ; Put half a coffee-cup (Zubereitung) of Pressopresso (or cappuccino/ Nescafe brand coffee) fill in the remaining half of the other with hot milk, top it up with a piece of extra whipped cream & a pinch of Nesquik.

## ESPRESSO

Preparation; 1 sachet of Pressopresso, (or instant coffee, Nescafe cappuccino/ Espresso Grandos brand coffee) add a small cup of Grand Marnier liqueur, please top it up with extra whipped cream & 2 Espresso: 1 sachet of instant Coffee, (Pressopresso, Nescafe cappuccino/marke kaffee) and add warm water, stirring it, sugar is added at a later time if requested.

## Tea (tee/tea/cay)

Turks are continuous tea drinkers (first most popular drinks were the buttermilk sherbet, sahlep, coffee then tea started.) The first thing is that the Turkish people offer is tea because it is a symbol of peace, the Turkish tea/color does reflects the temperature of the Turkish peoples, clarity of tea reflected in their blood, in red tulips, and color of red flag is blood in Turkey itself.

after dinner drinks 

## GROGS

Contains, warm water, sugar, fragrant plants & alcohol (choice of alcohol up to you). Place a spoonful of the Goblet of fire into 1 glass 23 grog bar k. sugar. 45 cl (4050 g) alcohol (rum, gin, cognac, whisky, Arrak, etc.). include 1/2 lemon juice & the Goblet of fire boiling water,decorate it with a slice (tranch) & large lemon rind, cloves, and cinnamon. The name comes from Admiral e. Vernon Alias Grog. in the 1730's while ship crusing in the cold ocean seas,to warm up,they created a enjoyable and delicious drink, they mixed boiling water with rum & sugar. Service: 1 serving plate &1 glass grog spoon

pré dinner/before dinner drinks 

## APÉRITIFS / aperatifler/aperitivo

Before dinner drinks/ appetizing drink

Strong dry (trocken/sec/secco) cocktails: ingredients are dry Martini, Gibson, Manhattan, kir (1 cl. crème de cassis liqueur "red currants Schwarzer Johannisbeer", 10 cl. dry wine)

Crème de cassis Royal kir (1 cl. "liquor", 10 cl. sek (dry/trocken/sec/secco)

Mediterranean countries dry wine, Port, Sherry (Jerez Xèrès), Samos, Marsala, Maderia (Madère), Malaga etc.. Aperatif drinks: alcoholic ones are vermouthe, Amer Picon (bitter), Campari soda (bitter), raki, ouzo, Pernod, Champagne (sek or orange juice); non-alcoholic ones fruit juices.

## PRÉDINNER/ before dinner drinks

short drinks  
fancy drinks



Pré Dinner Drinks (drink taken before a meal), which is included in the category of short drink Cocktails. Before dinner drinks must not upset stomach therefore must contain little alcohol. This cocktail contains, Gin, vodka, Vermouth, Cherry, Champagne, alcoholic beverages, such as the Martini, Campari Portwein. Before dinner drinks can be mixed with maximum (max) 2 cl sugar syrup or liqueur. According to the international standards PreDinner Drinks is a cocktail of the 7cl in total. Before dinner drinks, After Dinner & Long Drink contains the maximum of 5 items. For the most part before dinner drinks has little or no decor (non garnish). Decorating (garnish) is varied with ingredients.

## AFTER DINNERS

short drinks



After dinner, taken to relieve the stomach & help with digestion. The preparation contains whisky, cognac & various (liqueur) . Supporting material are ; milk, cream, eggs, coffee, fruit syrups, preferred. Use a maximum of 5 items & max. 7 cl..

## LONG DRINKS

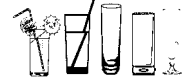

Of this long drink known as cocktail bars LongDrink has got a very great meaning. These kinds of long drinks categories; Highballs, Fizzes, Punches, Cobblers, Collins, some alcoholic beverages such as Flips, virtually any time, drinkable. this a spare time drinks such as, lunch time, afternoon coffee & cake among them, dance parties, at pool side gives great pleasure. All over the world it can only can have a maximum of 5 kinds of alcohol max, 8 cl, and with up to 14 cl with other mixers total up to 28cl. long drink cocktails is a term used for quantities.

## FANCIES/ fantasie

The whole world cocktails are prepared by using a various combinations of liquors by the bars. Predinner & After dinner as it is in the Article as there are no limitations on the alcohol measurement &. Approximately 30 are divided into groups; preparing the fancy drink, bartenders (barsupervisors barkeepers) using his creativity in the appropriate dekor ornaments & thus cocktail drink is becomes a fantasiable drink.If it Uses more than 5 items then it is called fancy Cocktail drinks. Very meaningful is this fancy drinks does not belong a specific group and does not have a specific preparation, can be a Imaginary (fantasy) with party names.

## FIXES

Preparations, and measurements are put direct inside glass .Melted sugar with not alot af water & lemon juice is prepared with the addition of required alcohol, decorated with bitter orange fruit slices (garnish), and other fruit slices.

## EXOTICS/ tropical drinks

There are plenty of non-alcoholic, alcoholic or colored South American drink is prepared from selected fruits such as pineapple, coconut, pampelmuse/grapefruit, etc. 2 pipette (2 straws 2 strohhalm) fruit and fruit container must have already previously kept in cooled place like pineapple/ananas tranche/pineapple cutting.

## CRUSTAS

Mise en place/preparation: Cut a lemon drizzle it at the top of the glass & drizzle with powdered sugar lightly over the top as well.

Fascinating after dinner drink. The desired fruit extracts such as liqueurs Crustas (liqueurs), fruit juices and the angostura put in the shaker (sh.) shake well, and service it with lemon or orange peels.



## CHAMPAIN COCKTAILS

Basic alcohol or liquor (liqueurs) blended champagne & sparkling wine (wine, champagne sparklings) prepared drinks. Suitable for many situations. prepared/ added with orange liqueur (liqueur) and/or cognac.

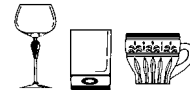

## CUPS/ bowls

Sparkling or white wines, this is the basis for the appropriate time to drink. The rate can be increased according to the fruit extracts, syrups, liqueurs (liqueurs), sugar, fresh fruits (lemon.) mixed with rose petals on demand, etc. Drinks are prepared and cooled with other materials just before service, soda can be added. A typical fun party drink. (party drinks)

after dinner drinks



## FRAPPÉS/glacials/glacés

Ice chilled drink varieties from the French, lively, light, after-dinner drink. Desired liqueur (liqueur) served with crushed ice. If required Syrups can be added. In Italy Frappes often mixed with, shredded ice frappes (cracked ice) milk / coffee and alcoholic or non-alcoholic drinks,

Service: 2 small pipette (2 small straws, 2 kleine strohhalm)

## HIGHBALLS

long drinks



Optional, thirst relieving large drink. the type of the desired drink that contains ice cubes, lemon, an alcohol & soft drink acidic (cola, ginger ale "ginger ale", etc.) name come from the gas/acid bubbles forms in the glass.

## JULEPS

Minty liquors (liqueurs) & chopped fresh mint leaves (the name comes from), prepared with sugar syrup, plenty of ice particles, alcohol & complimented with fresh mint leaves (peppermint/pfefferminze/2 persons (poivrée)/menta (piperita)/ menta, hierbabuena), in order to smell aroma/scent/ pipet(strow) shortened

after drinks



## POUSSE CAFÉS/Rainbow cocktails

This is the colorful layers of drink which can be created up to six variety of excellent color games drink, this after dinner drink thanks to its separate layers which can be the specific weights of liqueurs (liqueurs), fruit extracts or syrup. The measure does not applies to current practice rule, with more sugar and less alcohol makes it heavy. On a case-by-case basis, in the form of light to heavy product layers of

Carefully filtered directly into the Cup, followed by the next one, with the help of a bar spoon or teaspoon from bottom the surface, the other product is poured carefully & slowly, these creations, color games in an ambiguous way creating a nice drink.

## MISTS

This refreshing drink prepared directly into the glass with refreshing lemon peel, ice cubes, and alcohol. Gets the name from steamed glass.

## PICK ME UPS/strengthen me

This drink which livings you up against fatigue of jester has a sense of empowering, exhilarating.

long drinks



## PUNCHES/ five, 5, funf mixed by

They can be cold or hot, the shape of the original, which is from Sanskrit Pantscha foresees the use of 5 items: water, sugar, arrak (Brantwein/Brandy made from Palm products), fragrant herbs & lemon. Nowadays, numerous changes have been made. Bowle only. For single cold punch are generally made by using the shaker (sh), hot one is specially heated.



welcome / party drinks



## SANGRIA

This Spanish drink is made from many types of fruit & mainly red wines, including a stiff Pamplonada. The name is similar to the color of the Dark Red Bull blood, Sangres fruit aromas can be made from a few items. (bouquet/smell) to be good enough it is necessary to have fruits keep longer. Huge granular edible fruits can be eatable with.



## SANGARES

A modification of the Sangria & can be prepared quickly. Usually is based on the foundation of rosé or white wine, coconut is also added. Can be served hot or cold.

## RICKEYS

Great drink, in fact, the foundations of the spaciousness of Gin (gin), collins & drink are served with citrus peels, usually similar to a spiral.

long drinks



## SLINGS

Sling may be prepared only in the shaker (sh). Water, sugar, ice cream & limondan are formed with a stiff brandy & this blend is completed with Soda and Ginger Ale or other fruit extracts are added in the same way as a long drink.

## SPARKLINGS

Light, spaciousness, this drinks are colored with fresh fruit pure, mixed sparkling wines. If mixed with Ginger Ale and tonic water, it becomes Non-alcoholic drink.



sıcak / hot / heiß



soğuk / cold / kalt



## TODDIES

Essentially it is hot just for the cold days. Toddies Unlike the Punch and Groglar, it is sometimes preferred with cream, butter, etc. As Cold beverages it can be prepared with angostura bitters & lemon juice.

## ZOMBIES

Contains a high percentage of alcohol this is a large/long drink. There is plenty of ice in the Shaker (sh), fruit juice & plenty of mixed white rum.

Preparation; White and dark rum with plenty ice and fruit juice can be add little 75 °C strong Rum. According to one's taste garnish it with fresh fruits .

## HOT DRINKS

Hot & warm drinks for General concept.



## SOFT DRINKS

General concept for soft drinks.

## ON THE ROCKS

Do not constitute a particular kind. Simple drinks (pure/pur) or cocktails with 34 pieces of ice. Ornament on request (garnish).

## SHORT DRINKS

Small/short drinks up to 6 cl/60g will not be added to any drink to make it soft.

## SMASHES Collins & Juleps arası / Zwischen Collins & Juleps

Similar to Juleps (mintjuleps), it is prepared directly in its glass. Its name comes from fresh mint leaves & cracked ice being used. Garnishes: tranche lemon or orange. Service: 2 short pipets.

## SYRUPS / Sirops

Their basis elements are citrus and heathers fruits which had been stood (resettle) in Rum for 45 days, to compose refreshing - after meal drinks. Nowadays different fruit essences, fruits & sweet scented plants are also being used. Syrups could be preserved in fridge and they should be filtered before service. Garnish: fresh fruits.

## SWIZZLERS

They do not constitute any different category of drinks or associate with any. They are prepared directly in glass and lightly stirred up with a stick (swizzlestick).

**MIX.-LEXICON, TURKISH****Absolut Vodka / Votka**

İsveç yapısı vodka 1879 yılında Lars Olsson Smith tarafından "Absolutely Pure Vodka" (tamamen saf vodka) olarak üretildi, yalnızda arpadan yapılan Absolut Vodka, özel imbikleme metodları sayesinde içindeki istenmeyen tatlardan arındırılmış, hala arpanın karakterini koruyan Dünya'nın en saf & en yumuşak vodkası olarak biliniyor. Absolut Vodka'nın üreticisi Vin & Sprit, ürünlerini geliştirmek & gerçek imajı yakalayabilmek için ilk dönemlerde serum şişeleri kullanılmış & modern tasarımcılar tarafından üstünde çok az değişiklik yapılarak bugünkü şişe tasarımına ulaşılmış,. Absolut Vodka'nın alkol derecesi 40°, çeşitleri : Absolut Vodka (Sade), Absolut Citron (Limon), Absolut Peppar (Biberli), Absolut Kurant (Kuş Üzümlü).

**Afrodizyak / Aphrodisiack**

Sex özellikli, sex güçlendirici, arttırıcı, depolayıcı

**Alkol / alcohol / alkohol**

Kimyada elementi C<sub>2</sub> H<sub>5</sub> OH olan etil alkol mayalanmış şekerli sıvıların damıtılması ile elde edilen renksiz, uçucu, yanıcı & kendine özgü kokusu olan sıvı bir maddedir. Glikoz'un mayalanmasıyla elde edilen Etil alkol bütün alkollü içkilerin sarhoşluk edici özelliğini veren maddedir. Mono alkoller grubuna girer. Etil alkol 78.3 C° de buharlaşır.

**Ale**

eng.bitteres Malzbier / ing. acı malt birası

**Altolâtur**

Kokulu nebatların, alkol içinde meserasyonundan (meseration) elde edilen maddeye altolâtur denir, örneğin likörlerde koku & lezzetten arınmış alkol,kokulu çiçek, kök, kabuk, yaprak & tohumlardan, olgun & çürük olmayan taze kokulu meyvelerden yapılır.

**Advocaat / Avukat**

Yumurta sarısı & brandy ile yapılan krema kıvamında sarı renkli Hollanda likörü

**Anisette**

Anason aromalı/kokulu, tatlı likörlerde kullanılan fransızca terim. (liqueur / likör)

**Amanda:**

Metaxa brandy, kahve likörü & krema karışımı likör.

**Ameretto di saronno**

İtalya'nın Saronno bölgesinde yapılan Acı badem likörü, "afrodizyak / aphrodisiack" özellikli bir içkidir. Kahve yanında giden / tavsiye edilen en iyi likör.

### Amaretto de Romanzo:

Acı badem likörü.

### Amazona

Marajuya (Maracua/Marakuya) likörü

### Angostura-Bitter

(Aromatic bitters) Antiller, Venezuela'da bir ağacın kabuğundan (Angostura baums / Angostura ağacı) & bitkilerden (portakal kabuğu, tarçın, kardamom, Chinarinden / kına kına, karanfil) yapılan bitter/acı, tatlandırıcı sos, kokteyllerde kullanılır.

### Apricot Double

Kayısı likörü.

### Absinthe/Absint

Pelin yaprağı, ardıç tohumu, melek otu, tarçın, alkol & portakal çiçeği ilavesi ile yapılan aperitif içki.

### Apple-jack

Amerikan deyimiyle Elma-brendisi (apple-brandy). digestif.

### Arquebuse de l'Hermitage

Fransız yapımı bitki / Kräutergeist, damıtık içki.

### Armagnac

Brendinin, Weinbrand, 1907 Fransa şarap kanununa göre, Cascoigne bölgesindeki, yanan, yakılmış, destille edilmiş, damıtılmış şarabın adı. Cascoigne bölgesinde yapılan armagnac asidi fazla şekeri az üzümlerden çekilen şaraplardan yapılı & fiçılarda 3 sene dinlendirilir. Çok tutulan bir Weinbrand (Brandy), konyağa (cognac) benziyor, konyaktan 200 yıl daha eski olup, tarihi 1461'de başlar. digestif

### Arrak

Rum'a benzer bir içki, pirinçten, ağaçların cicilerinden & palmadan elde ediliyor. Java (Batavia-Arrak) & Hindistan'dan ithal ediliyor.Pirinç rakısı. (import)

### Asbach Uralt

Weinbrand / Alman brendisi (Weinbrenner Hugo Asbach) "Im Asbach-Uralt ist der Geist des Weines! / Şarabın ruhu Asbach-Uralt'da"

### Baileys

(Irish cream) Irish whisky, kahve & krema karışımı likör.

### Bar

Fransızca engel anlamındaki Barrière'den gelir. Amerika'da Cowboy'luk zamanında mağaza sahipleri müşterilerinin, mallarına zarar vermemesi (veya çalmaması) amacı ile Barrière (engel/tezgah/teke) yapmışlar. Müşterileri sıkılmasın diye açık içki de satmışlar. Bu işin karlı olduğunu gören işletmeciler saloon adı altında bar işletmeciliğine başlamışlardır. Minimum h.:1.14 m., Maximum h.: 1.18 m.dir, üst tezgah kanallı olup, genişliği 0.50 m.'dir, bar tezgahı içinde buz makinesi, sıcak & soğuk su tesisatı, bardak yıkama makinesi mutlaka olmalıdır.

## barman :

e. o. / m. w. /m. h.(profesyonel cocartlı, vizeli turist rehberleri gibi en az 3 lisan bilen, mesleki alt yapısı çok yüksek, ufku geniş, kültür seviyesi çok yüksek, sır tutmasını bilebilen, çağdaş, dürüst, başkasının rızkında gözü olmayan,müşterisi ile sırdaş, yoldaş, arkadaş olabilen, karşısındakinin yüksek & alçak seviyesine inebilen kişidir. Barman ' lik hafife alınamayacak bir meslektir. Hafife alanlar alkolizmin kurbanı olurlar, karşısındakinini asla hafife almazlar, aldıklarında ödeyecekleri bedelin çok ağır olacağını bilendir. Barman, aynı zamanda, bir barda peynir eşliğinde rakı içenleri gördüğünde, yandan çarklı ada vapurunda çilingir sofrasını kurup, papazın düzünü içen Neyzen **Tevfik'**lerin, Ahmet **Rasim'**lerin yada ayakçı meyhanesinde yumruğunu meze yapanların, kemiklerinin sızlayacağını düşünendir.**O, kısacası bir mixolog'dur, bir gastro-nom'dur,** müşterisi ile organik bir bağ kurup içkisini hazırlarken, bir şiir söyler gibi bir senfoniye çalar gibi, ya da bir bale'yi icra eder gibi olmalıdır armonik & dört dörtlük  $\frac{4}{4}$ ).

### "ayaklı meyhane & yumruk mezesi" ( Gedikli: Osmanlı' da meyhanelere verilen ad.)

Osmanlı döneminde ayaklı meyhaneler seyyar içki satıcılarıydı. Çoğunlukla ermenilerden oluşurdu; dükkanı, tezgahı, fıçısı, ustası, sakisi hep kendisiydi. Ayaklı meyhaneler, ucu musluklu, içi rakı veya şarap doldurulmuş gayet uzun koyun bağırsağından oluşan içki depolarını bellerinde 3 tur atarak sardığı bağırsağın içi kızılca şarap (iblis'in sidiğı) doluydu. Sırtlarındaki uzun cübbeyi maharetle arkaya atarak cübbenin iç cebinde asılmış kadehi bağırsağın ucuna takılı musluğu açarak doldururlardı. Ayaklı meyhaneler en çok bahçekapı & yemiş iskelesi, galata civarında dolaşırlardı. Müşterilerini gördüklerinde etrafi kollayarak bir manav veya bakkal dükkanına girerler kuşağının arasından kadehi doldurup, peşi sıra gelen müşterilerine vücudunun harareti ile ısınmış içkiyi sunarlardı ; kadehi bir yudumda yuvarlayan meftun /ayyaş da bir üzüm tanesini yahut mevsimine göre bir meyveyi / leblebileri meze yaparlardı. Leblebileri yemeden önce yumruğunun tersiyle ağzının kenarına akmış şarabı temizlerlerken akan damlayı ağzına sürerlerdi. Buna da **yumruk mezesi** derlerdi."

Profesyonel bir barmenin 2 ayrı kılıflı, bilenmiş bıçağı bulunmalıdır.( meyve & tranche limon bıçağıdır, birbirine karıştırılmaz.)

## barmaid

barman' in dişi versiyonu, bar tezgahı / desk / banco arkasında çalışan bayan.



sifon / syphon



### Bacardi

Beyaz Cuba/puerto rico Rum'u şeker kamışından yapılır, ispirotolu içkiler sınıfından.

### Basis

Alkolün temeli / yapısı.

### Batıda de Coco

Rum & Hindistan cevizi sütü karışımı likör.

### Becher / cup, mug

Kupa, kadeh, tumbler.

### Bénédictine D.O.M. (Deo Optimo Maximo)

16. yy.'da Normandiya'da Fécamp'ta Benedik manastırı rahiplerinden birinin kilise bahçesinde yetiştirdiği otlardan yapılmıştır. Bu ünlü likörün formülü gizli tutulmaktadır. Tahmin edilenler kekik, öküzgözü vs'dir. Deo Optimo Maximo sözcüklerinin kısaltılmışıdır, "en büyük olan Allah adına" ulu tanrı için anlamına gelir, şişelerinin üzerinde cross / kreuz / † , hac olursa formülünün & gelirinin kilise yararına olduğu belirtisidir. Kilise bahçesindeki otları, meyve, bitki & çiçeklerden otlayan hayvanların mayhoş olduğu gözlenerek keşfedilmiştir. digestif

### Bergomette

Fransız armut likörü.

### Bitter'ler / bitters

Muscat (hint cevizi), pelinotu, meyan kökü, v.s.gibi çeşitli bitkilerin kök, yaprak, kabuk & çiçek'lerin esansları nötr alkole yatırılıp aylarca bekletilip aromaları & esansları alınır. Mide ekşime & rahatsızlıklarına iyi gelir. Kokteyllerde tatlandırıcı olarak kullanılırlar. Pick-me-up (sade) veya soda ile karıştırılıp içilebilirler. Bilinen markalar: Angostura bitter, orange bitter, peach bitter, underberg, fernet branca, ferro china, cynar, toni kola.

### Bira / Beer / Bier

Arpa suyuna maya katıldığında ham biraya dönüşür. Arpa maltı sırasına şerbetçi otu katılır, bira mayası karıştırılıp mayalanır (Fermented / Gärung) elde edilen & içinde eriyik haldeki karbondioksit gazı bulunan, kendine özgü tad, koku & rengi olan 3.5-5° alkole bira denir. Birada vitamin bulunur. Denizciler yüzyıllar boyunca gemilerine malt, su & karıştırmak için fiçı yüklediler. Çünkü bira iskorpit gibi, vitamin eksikliğinden kaynaklanan hastalıklara karşı savaşmalarına yarıyordu. Özellikle B grubu vitaminleri (B1,B2,B6,B12) & PP vitamini açısından zengindir, aynı zamanda biraz da C vitamini içerir. Son olarak, başta potasyum & magnezyum olmak üzere çok miktarda mineral içermektedir. (bknz. S. 132' vita/ vitamin.)

### Birahane

Bierlocal / beer-house / local pub.

### Bourbon

Amerika'nın Kentucky bölgesinde mısırın destile edilmesiyle yapılan malt & blended whiskey. amerika'nın ulusal içkisidir.

### Brack Palinka

Macarlara özgü kayısı likörü.

### Brendi

Türk & serbia / sırp brendisi.

### Café / Kahve / Kahvehane / Kafenes / Kafenio / Kafe / Café Turc:

Chef de Rang /garson'un servis yaptığı lokal, tea-room, teeause / çay evi.

### Cafeteria

Self servis yapılan lokal.

### Café Brunch

Geç kahvaltı, öğle yemeğine yakın, sabah & öğle arasında her çeşit yiyecek büfe servisi, self servis, büfe servisi.

(Br)akfast - L(unch) / Z'morge- Z'mittag / S'abah-Ö'gle arası)

### Cachaça

Brezilya yapısı beyaz rum/rom, ilginç bir içiliş biçimi vardır.

### Caiprinha

Brezilya yapısı, serinletici içki, Cachaça, lime suyu, şeker yapısı / Bassis.

### Campari

İtalyan bitteri, çeşitli bitkilerden yapılan bitter, acılı içki. Bitterler kategorisindedir. (Örneğin: Angostura Bitter, Orange Bitter, Fernet Branca, Underberg, Cynar vs.)

### Catering

Party liferant / Gastättengewerbe / Gastwirt / Hotelier / İkram servisi.

### Cream de Coco

hindistan cevizi likörü.

### Cedrat / Cedra / Cedratier

Ağaç kavunu esansından yapılan likör.

### Capricornia

Avustralya yapısı tropikal meyve likörü.

### Chamberry

Fransa'nın, Chamberry bölgesi yapısı dry vermut / vermouht.

### Chamberryzette

Fransız yapısı, yabani çilekten yapılan içki.

### Cherry Nalivka

Rus (Baltık) yapısı vişne likörü.

### Cherry Whisky

Gean Whisky, Guyne Whisky, Chesky Whisky / viski, kiraz & vişneden yapılan içki.

### China

İtalyan yapısı bitter & tatlı (bitter/süßer) bitki likörü, (aus Chinarinde)

### Cinzano

İtalya yapısı vermut & şampanya / sekt / champagne “aperitif”

### Cidre

Fransız yapısı elma şarabı (Äppelwoi) 3 çeşittir. 1-) tatlı / süß / doux, 2-) Yarı tatlı / halbsüß / demi sec, 3-) Sek / trocken / sec.

### Creme de Violettes

Fransız yapısı menekşe likörü.

### Coffee Break

Kahve molası.



### Creme de Cassis: (red currants/Johannisbeer)

Fransa yapısı frenk üzümü, ağaç çileği, kiraz, karanfil, tarçın & alkolden yapılan likör (şurubu da vardır), tatlandırıcılarda kullanılır. (\* grenadine syrup yerine de kullanılır), (kokteyllerde örneğin: kir/kir royal)

### Creme de Noyan

Fransız yapısı, şeftali, kayısı çekirdeğinden, portakal çiçeğinden yapılan badem kokulu likör.

### Calvados

(äppelwoi / Mostäpfel / Apfelschnaps / Eau-de-vie de Cidre) Normandiya yapısı elmadan destile edilen Apfelbrand / elma brendisi.

### Campari-Bitter

İtalyan yapısı bitter likörü.

### Champagne / şampanya / sparkling wine / sekt

Fransa'nın Champagne bölgesinin adı. Tarihi 18. y.y.' dayanır. Yapımı ilk olarak Piskopos Don Péérignon tarafından gerçekleştirilmiştir. Köpürmeye eğilimli olan üzümlerden yapılan şarap, şişelenip mantarlanır, mahzenlerde (wine / wein-Lager) şişe çeviriciler günde 15° çevirirler, Zamanla oluşan kabarcıklar patlatılıp dışarıya atılır & şişe mantarları yenilenir.

### Cherry Herring

Danimarka kiraz likörü.

### \* Curaçao

Curaçao bitterorangen / Curaçao bitter portakalları veya karibik pomeranzen adındaki cins portakaldan hatırlanır. Gıda boyası ile renklendirilmiş portakal likörü (sarı, mavi, yeşil & kırmızı renkleri vardır.) adını Hollanda Antilleri'ndeki bir adadan alır. (Curaçao Triple Sec % 38° bitter portakallardan yapılan beyaz likör) Cointreau & Grand Marnier'deki yapısı / basis, Curaçao- portakallarından kullanılır.



### Coca-Cola(kokakola)

1880'li yıllarda ilk olarak Amerika'da çeşitli bitki esansları, başta kola bitkisi yaprakları & meyvesinin esansları olmak üzere su, şeker & asitle yapılan gazlı bir meşrubattır. Şeker yanığı olan karamelle renklendirilen meşrubat.

### Cognac/french brandy/konyak/kanyak/coñac/Kognac

Brendi'nin, Weinbrann'd, 1907 Fransa şarap kanununa göre tescillenmiş, Charente bölgesindeki, yanan, yakılmış, destille edilmiş, damıtılmış şarabın Charente bölgesindeki Cognac kasabasının adı toprağı kireçli & çakılıdır. Cognac en önemli özelliğini buradan alır. Cognac asidi fazla şekeri az üzümlerden çekilen şaraplardan yapılıır & fiçılarda 3 sene dinlendirilir (fine champagne) digestif.

### Cointreau

Tanınmış Fransız likörü, Triple sec & Çuraçao'ya benzer. Cocktaillerde Triple-sec'in yerinde kullanılabilir. digestif.

### Cordial

Meyve likörleri, ahududu (raspberry / himbeer), şarap & şarabın destille edilmesi, damıtılmasından elde edilen içkiler. İngiltere'de çeşitli meyvelerin konsantre edilmiş alkolsüz şurubuna verilen bir ad.

### Crème

Şekeri çok olan bir likör derecesi azdır.

### Curaçao / kurosao / kürassào

Bir çeşit acı portakal (bitterorange / bitteroranj) kabuğundan elde edilir. Antil adalarından Curaçao'da yetiştirilir. Triple sec & cointreau'a benzer. "Dutch West Indies" digestif.

### crusst / depot

Yıllanmış şarapta dibe çöken tortu.

### Cynar (çinâr)

İtalyan yapısı enginardan yapılan bitter, aperitif içki. Kinin enginar & çeşitli baharatlara yapılan kırmızı renkte, acımtırak tatta olan bir İtalyan aperatif içkisi. Sade veya sodalı su ile soğuk olarak içilir.

### Danzier Gold Wasser (Altın Suyu)

Altın likörü.

### Damıtımcı

Destille eden, destilleci / Stillman / Destilliermann / Wein-brenner

### Damıtma

distillation / destillation.

### Damıtılmış

Destillate / destillat.

### Darı / millet / Hirse

Kuraklığa dayanıklı tohumları, gerektiği zaman buğday (Weisen / wheat) yerine besin olarak kullanılan tahıl (Getreide / wheat / blé).

### Doley / bardak altı, altlığı / Beer Mat / Bier Mate

Avrupa & Amerika'da çok çeşit bira bulunur. Profesyonel birahanelerde, işletmelerde barmen & barmaid'lerin takibi kolay olsun diye her marka & kapasiteli bira bardaklarında (örneğin: 0.33 litre-0.4 litre-0.5 litre gibi) siparişlerde hangi marka veya kapasitede bira sipariş verilmişse, servis elemanı o marka & kapasitedeki doley'i o biranın altına koyup, bir çarpı atar. Müşteri ne kadar içiyorsa, Doley'in üzerinde o kadar çarpı vardır.

Hesap isteyen müşteri Doley'i alıp,

barmen'e, barmaid'e veya direkt ana kasaya öder. (bu profesyonel system Türkiye' de maalesef hala barlarda kullanılmamaktadır !)

### Dubbonet

Fransa yapısı, kırmızı şarap, bitkilerden & kokulu baharatlardan yapılan bitter, aperitif, anasonlu içki (wein Gewürze - Basis).

### Duduvaça

(Volvodina) Serbia / Sırp dut rakısı.

### Drambuie

Viski & bal, baharat likörü. (dram: yudum) digestif

### eau distillée

damıtık su.

### Eau de vie: (lebenswasser / yaşamın suyu, hayat suyu / water of life)

Fransız deyimile dut, çilekçiller & meyvelerden yapılan brendi, damıtılmış, destille edilmiş içki.

### Eau- De-Vie De Marc:(o-dö-vi-de maark)

şarap yapılmak için sıkılan üzümün geride kalan cibresinden damıtılarak yapılan bir tür brandy.

### Engelhard Blackberry Double

böğürtlen, diken dut'u likörü.

### Engelhard Cherry Double

Kiraz likörü.

### Engelhard Chocolate Double

Kakao, şarap & menthe likörü.

### Engelhard Coffee Double

Kahve likörü.

### Engelhard Orange Double

Portakal likörü.

### Engelhard Ginger Double

Ginger (zencefil) şarabı, spirit & İskoç viski likörü.

**felixion / feliksiyon (hovarda banyosu) :**

barman' in vakit bulamadığı zamanlarda bir sıcak sulu kap içerisinde mermer-şahi'yi (kurulama bezini) sabınlayıp acele vücudunu firiksiyonlaması terini atıp mesaisine devam etmesi.

**Fernet-Branca**

Mide bitteri, aromalı/kokulu bitki & ot köklerinden yapılır. Mide ekşime & bozukluklarına karşı kullanılır. Bu içki genellikle aperatif olarak veya daha çok mide ekşime & bozukluklarına karşı bir düzeltici olarak sade içilir. Bkz. Aromatik acılar.

**Galliano**

İtalyan vanilya / vanille, bitki & baharat likörü. Exotic / Tropical kokteyllerde kullanılır.

**Gallweys (galveys)**

Viski esaslı, çeşitli bitkiler, bal & kahve ile yapılan likörü.

**Gastronomy / Gastronomie / Gastronomi**

Damak zevki bilimi. Yüksek yemek pişirme sanatı (masa sanatı), lokal işletmeciliği "Feinschmeckerei".

**Gespritz / geşiprits**

Avusturyaya özgü beyaz şarap & soğuk maden suyu karışımı aperitif içki

**Gourmand / Gourmed**

Damakçı, tadımcı, içki tadını koklayarak veya tadarak anlayan fachman / mesleki kişi. "Feinschmecker"

**\* Gıda Boyalı / \* dye-stuff / \* Mit Farbstoff**

**\*\* Gıda Boyasız / \*\* Ohne Farbstoff**

**Gin / cin :**

(London Gin veya Dry Gin) İngiliz berrak kuş üzümü (Wacholder / Wacholderbeere / baie de genièvre / juniper-berry) brandy / branntwein, ispirotolu içkiler sınıfından. Başta ardıç ağacının meyvesi & diğer bitkiler ile birlikte 2 kez imbikten geçirilip damıtılır. (wahcholderbranntwein)

**Ginger Ale**

Zencefilli gazozu, zencefil bitkisinden yapılan gazoz.

**Ginger Lady**

Fransa'da zencefil & diğer bitkilerden yapılan aroması yüksek likör.

**Grand Marnier**

Cognac, portakal & bitkilerden elde edilmiş enfes bir Fransız likörü. digestif

**Genepi (Génèpi de Alpe)**

Pelin likörü.

**\* Grenadine / Granatapfelsirup**

Nar şurubu, koyu kırmızı renkli. İngiliz yapısı nar çiçeği esansından yapılan şurup / syrup (likörü de vardır). tatlandırıcı & renklendiricidir, kokteyllerde

sıkça kullanılır. \* Creme de Cassis (red currants / johannisbeer) yerine de kullanılır.

### Grozdovaca

Üzümden yapılan Balkan rakısı (ayrıca mısırdan yapılan rakı da vardır).

### Hors-D'œuvres

ordovr tabağı.

### Ice Sharpaner

Buz kırıp (slach-ice / Schnee Eis) kar buz haline getiren makine, alet.

### Irish Mist

Irish whisky, bal & birtakım bitkilerle kokulandırılmış İrlanda likörü.

### Irish Cream

Irish whiskey & cream / sahne / krem şanti likörü.

### Jameson

İrlanda yapısı Whiskey. 1780 yılında Dublin'de John Jameson, damıtma fabrikasını kurdu. Viski üretimine en uygun türdeki arpayı yetiştirmeleri için İrlandalı çiftçileri cesaretlendirdi & onların manevi öncülüğünü yaptı. Jameson'ın içki fabrikası, Jameson ailesinin nesiller boyu özenli yönetimi altında gelişip büyüdü & 20. yüzyılın başlarından itibaren üretilen viski bütün Dünya'ya ihraç edilmeye başladı. Jameson İrlanda Viskisi, malt edilmiş & edilmemiş arpayla diğer tahılların karışımından yapılıyor. Malt yumuşak & doğal bir tat sağlamak için kapalı fırınlarda kurutuluyor & her biri daha ileri bir arınma sürecine yol açan 3 ayrı damıtmadan sonra Jameson whiskey elde ediliyor, bir başka özelliği de, diğer viskilerdeki ağır kömür & malt kokusunun duyulmaması.

### Kahlua

Meksika kahve likörü.

### Kandis / Candy / Candi (candied / kandiert)

Meyve şekerlemesi (örn. kıyamık şekeri/sugar - candy, kandis zucker, rock candy / sucre fordu).

### Kelch / cup, goblet

Ayaklı kupa, çanak (örneğin: dondurma kelch / eiscremekelch / ice-cream kelch, cup, kupa.

### Kumovica

Üzümden yapılan Balkan rakısı.

### Kumquat / Komquat / kamkat

Zeytin büyüklüğünde mini oranj renkli turunç, mini portakal / mini orange. (örn.: Opera Cocktail (bkz.354).)

### Kamschatka / Slatkaia Trava / Spondilium Foliolae pinnatifide

Rusya'da yapılan tatlı çimen brendisi, Russian Sweet Grass Brandy.

### Karambole(n)

Sternfrücht(e) / yıldız şeklindeki meyve(ler), tropical / exotic kokteyllerde kullanılır.)

### Kirschwasser (kirschbranntwein)

Keskin kiraz brendisi, en tanınmış İsviçre & Schwarzwälder kirazıdır / schnapps (schnapps), Alman kiraz likörü.

### Kiviaruba

Kivi likörü

### Kruskavac

Serbia/Sırp & Hırvat/Slovenia yapısı armut rakısı.

### Krupnick: (krupnic)

Bal ile yapılan bir Polonya likörü.

### Komavitsa

Kosovo & Serbia / Sırp üzüm rakısı.

### Konjak

Serbia / Sırp & Hırvatistan brendisi.

### Likör / Liqueur:

Alkolü sonradan ilave edilip yapılan içkilere likör denir. Örneğin Branntwein / brendi minimum % 10 şeker & % 10 alkol içermek zorundadır. Çeşitli meyve & meyve özlerinden, baharatlarla, şeker & alkol ilave edilerek bir süre bekletilmesiyle (meseration / meserasyon) elde edilirler. Eau de vie'ler (suma) şaraba hasıl olup, damıtık (destille edilen) tüm içkilere denir. Likör yapılacak meyvenin, şarapta & alkolde bir süre ıslatılıp bekletilip meserasyona tutulup, yapılır. Veya meserasyona tutulup yapıldıktan sonra, damıtılıp yapılan likörler de vardır (Örneğin: Apricot brandy, cherry brandy gibi) Saf alkolün içine koku, meyve usaresi (suma'sı), baharat, şeker, su v.b. katılarak hazırlanırlar. Meyve, alkola, enfüzyon & esansla imal edilirler, her türlü hububat, çiçek, kök, kabuk, kaliteli meyveler, kaliteli turunçlardan yapılırlar, kokteyllerde sıkça kullanılan yardımcı, tatlandırıcı, renklendiricidirler. Likörler 3 yapıya ayrılırlar, 1) Extrafeine Liköre (extra-fines) 35°-45° 2) Feine Liköre (fines) 25°-35° 3) Gewöhnliche Liköre 20°-30° .

### Lozovaça:

Kosovo yapısı üzüm rakısı.

### Malibu:

Hindistan cevizinden rum tekniği ile elde edilen bu Jamaica içkisi Hindistan cevizi sütlü rum (likör benzeri).

### Malt / malz

Nişastası yüksek arpanın ıslatılarak çimlendirilmiş hali (nişasta şeker'e dönüştürüldükten sonra alcohol / alkole dönüştürülür.

### Mangal

braizer / barbecue / kohlenbecken.

### Mangal kömürü

odun kömürü / charcoal / holzkohle

### Maria Brizart

Anisierte liqueur / Fransız anasonlu likörü, nane yapraklı bitki likörü, creme de banane, kayısı, ahududu, ağaç çileği likörleri.

### Matiz

Alkollü / meftun olan / narkoz almış kişinin orta oyunu rolü, dead drunk, die rolle des Betrunkenen Spielt.

### Mayalı

Fermented / Gärung / Covage / Fermentation.

### Mei Kuei Lu

Çin yapısı, gül yapraklarıyla damıtılmış, darı (millet / Hirse), schnapps'ı.

### Menu à la carte

Nach der Karte / kart tarzı menü, kart'tan menu (kart'a bakıp, extra menu siparişi)

### Mermer Şahi / Mermer Şah

Amerikan bezi, taşlanmış, yıkanmış, beyazlatılmış. servis barde bardak kurulama bezi. Tülbent, bardak silmek için toz bırakmayan bez / peşkir, kurulama bezi

### mezkal

kaktüse benzer bir bitki, iç göbek kısmı kabaca doğranır, ağırlık koyarak basınçla haşlanır, suyu alınır sonra maya & şeker katılarak fermantasyonu sağlanır.

### meseration / meserasyon

Likör yapılacak meyvenin 30 ° ile 95 °lik alkolde, belirli bir sürede ısıtılarak bekletilmesine meserasyon denir. Sonra da damıtılırsa, destille edilirse, o meyvenin saf alkolü, eau de vie, suması elde edilir.

### meyhane

local Pub / kneipe / joint / dive.

### meyhaneci

puplican / barkeeper / kneipenwirt

### metaxa :

kaliteli Yunan brendisi. \*

### mise en place

Vorbereitung / yiyecek & içecek servisi ile bar yönetimindeki ön hazırlık. Fransızca.

### Milwood

(Irish cream) Irish whisky, kahve & krema karışımı likör.

### Mirabelle

Erik likörü. (Fransız)

### Mixology / Mixologie / miksoloji / fachliteratur

İçki / kokteyl karışım bilimi.

#### Mozart:

Avusturya'nın Salzburg kentinde yapılan alkol & çikolata nугatı karışımı likör.

#### Napoleon Mandarin

Konyak & mandalina karışımı likör.

#### Nega Fulo

Brezilya yapımı cachacca (çaçaça) rum / rom.

#### Orange bitter

Orangen bitter, cocktailleri tatlandırmak için kullanılan bitter / tatlandırıcı sos

#### Oriental / şark

Alman mocca (kahve) likörü.

#### Ouzo

Yunanlıların ulusal / milli içkisi (schnaps) rakı benzeri anasonlu/anis/aniseed içki, Yunan rakısı, ispirotolu içkiler sınıfındandır.

#### Pastis

Fransız aperatif anasonlu anis/aniseed Fransız aperatifi.

#### Peach Tree

Şeftali likörü.

#### Peat / Piit / Torf / Tourbe / turba

Dünyada yalnız İskoçya'da yetişen fosilleşmiş bitki, az çok kömürleşmiş bitkilerden oluşan yakıt, iskoç viskisine (scotch whisky) özel koku (aroma / bukett, flavouring / arôme) veren yakıt. "Peat-Cutting / Torfscich: kurutulmuş turba yakıtı"

#### Pernod

Temeli anason / anis & vermut su ile inceltilerek içilir, Apsinthe yapımında kullanılan pelin yerine anason kullanılarak yapılan Fransız aperitifi, rakısı.

#### Pisang Ambon

Endonezya'da yetişen bir bitkinin yapraklarından yapılan Hollanda likörü.

#### Pitu

Brezilya yapımı, şeker kamışından yapılan brend / brandy / branntwein.

#### Pokal

Kupa, cup, goblet.

#### Portwein

Tatlı, aromalı bir şarap Porto / o porto (Portekiz / Portugal / Ugal Limanı) liman anlamındadır.

#### Prepeçenitsa

Serbia/Sırp üzüm rakısı.



## Prunelle

Erik likörü.

## Rakı - Aslan Sütü - löwen milch - lion's milk (arrak - rozaki - rakia) :

Türklerin ulusal / milli içkisi (schnapps / schnaps) Ouzo benzeri anasonlu anis/aniseed içki, ispirotolu içkiler sınıfından, yüksek dereceli kuru & yaş üzüm (- 93° - 94°) ispirotusunun, yani suma'nın anason tohumlarıyla 2 defa damıtılmasıyla (destille) elde edilen içki, su katılarak içilir & yanında extra su bardağı ile servis edilir.

## \* Red Orange:

Gıda boyası katkılı portakal likörü.

## Restaurant

Fransızca Restaurabo'dan gelir iyileştirme (yenileştirme) anlamındadır. Restore etmek, iyileştirmek. "lokanta / Gasthaus / ristorante / Restaurante / lokal"

## Rubinvinjak

Serbia/Sırp yapısı brendi.

## Rum

Şeker kamışından & pancarından yapılan içki Dünyaca tanınmış markalar : Jamaica-Rum, maun renginde(mahagoni farbig) & Cuba-Rum, mısır sarısı renginde (strohgelb) (rhum-rom-roum) ispirotolu içkiler sınıfındadır (kategorisindedir).

## Sake / saké :

Pirinç şarabı, rakısı, damıtılarak destille edilir. Japonların ulusal / milli içkisidir. Genellikle sıcak olarak küçük fincanlarda içilir. Acımtırak & renksiz. (rice wine) "sıcak veya soğuk içilir."

## Schale / peel, bowl:

Schale, peel: meyve & patateslerde kabuk anlamındadır, Örneğin: limon, portakal kabuğu / Zitronen & orangenschale / lemon, orange peel. Peel: Yumurta, kabuklu yemişlerde, midyelerde kabuk anlamındadır. shell: Tahıllarda kabuk anlamındadır. bowl-schale: kâse, çanak anlamındadır. (gefäs: kap) örneğin: "dondurma schale / eiscremeschale / ice-cream schale."

## Sh. / Shaker

Schütterbecher / coctelera / çalkalama kabı, çalkalayıcı, miksoloji / mixtarius / mixology / mixologie. 2 çeşit shaker vardır, 1) standard-shaker: 3 parçadır, bir parçası süzgeçli olup, buz parçalarını shaker'in içinde tutar yani bar süzgeci / barsieb / bar strainer vazifesini görür & aynı zamanda bu parça yumurta ayırıcısıdır. 2) Boston-Shaker: Bunda bar süzgeci / barsieb / bar strainer kullanılmak zorundadır ama pratik kullanımlıdır. Yarısı metaldendir, yarısı da camdandır & camdan kısmı mixglass / Rührglas yerine kullanılabilir. Shaker'lara kokteyl başına 3 küp buz konulur & kesinlikle 10-20 saniyeden uzun shake / schütteln / çalkalama yapılmaz, shake / çalkalama sağ veya sol omuz üzerinden shaker ters bir şekilde çevrilip kapak kısmı baş parmaklar ile tutulup havada 8 şekilde yapılır.

## Simeon / rakia

(Sungurlarska / Grozdova / Rakia) Üzümünden yapılan Bulgar rakısı.

## Stick / Stik / Rührstäbe

Kokteyl şişi, çubuğu, cocktailshish / cocktailspieß / Rührsäbel, çubuk, plastik kokteyl karıştırıcı.

## Spirits / spiritus / ispirto

Spirituosen, weingeist, alcohol, alkohol, alkol.

## Şarap / Wine / Wein

Mayalanmış taze üzüm suyu, kabuklarından doğal olarak kendiliğinden alkole dönüşerek şarap olur. Ayrıca günümüzde şarap mayasında kullanılır. Asıl vatani Anatolien (Anadolu)'dir. İlk şarap kadehi Anatolien'de bulunmuştur. "*Anatolia Anadolu / Anayurt anlamında olmayıp Assos' ta tanrıça Kybele'nin ellerinin arasından doğan güneş demektir, Rumca doğu anlamındadır.*" Tarihi insanlık tarihi kadar eski olup dini sebepten asma kökleri Anatolien'den güney Avrupa ülkelerine yani Akdeniz ülkelerine geçmiştir. Brandy/cognac' nin ana malzemesidir. en sağlıklı & hijyenik içkidir, besleyicidir. kolesterol düzeyini azaltır. Tıpta olumludur. Şarabı yazmaya kalkarsak whisky brandy & cognac gibi başlıbaşına kitap olur. Das erste richtige weinglas in Anatolien gefunden, Anatolia; Güneşin yolu (Sunway, sonenweg) demektir. Asos'da tanrıça Kybele' nin (Anatolia) elinden doğan güneşin adı.(Cuvée "A batch, barrel, or cask of wine"). Eski şarapların, yaklaşık 20 yılda bir mantarları değiştirilir, şişelerin mahzende yatık durması & etiketlerinin yukarıya bakması gereklidir. Porto şaraplarının & shery'lerin (aperitif likör benzeri liman şarapları) ise ispirotolu içkiler gibi dik konulabilir. Mahzenden şişelerin servisten 2 saat önce çıkarılması gerekmektedir, içme ısı beyaz şaraplar için 12-15°C, kırmızı şaraplarda 18-20°C'dir.

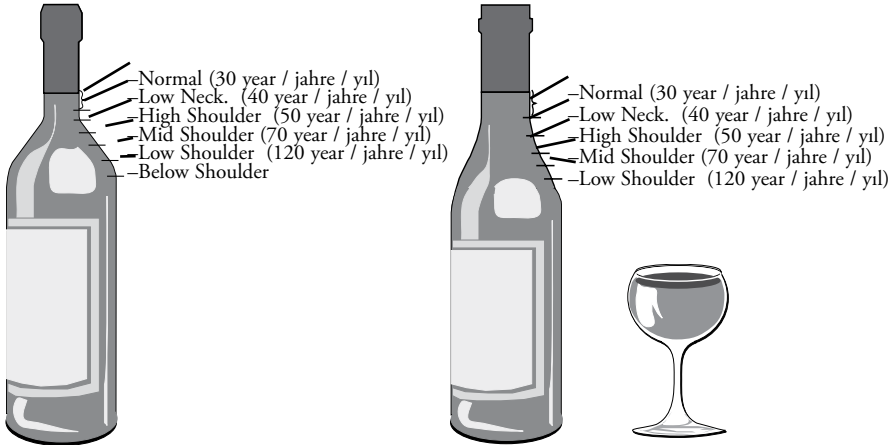

Şişeler boyun kısımlarından eğik bir biçimde baş aşağı şaraplığa konur.(Dışarıdaki hava ile şişenin içindeki mantar altı havanın sirküle olması şarabı bozacağından şişeler baş aşağı konulur. Şarap şişesindeki hava şişenin dibine indiğinden hava sirkülasyonu kesilmiş olur.)

Hergün şişeler saat yönünde çevrilir. Bunun için görevli olan kalifiye elemanı her gün 30.000 şişe çevirmektedir.

**Ölçülü olmak kaydıyla içilen içkiler sağlığa faydalı da olabilir.** Bu içkilerden biri şarap. Şarap yalnız alkol içeren bir içki olarak düşünülmemelidir. Bira & diğer alkollü içkilerin bu koruyucu etkiyi göstermemesinden yola çıkan araştırmacılar, şarabın etkisinin alkolden değil, doğal maddeden kaynaklandığını saptadı. Şarabın içerdiği vitaminler, asitler, azotlu bileşikler & çok sayıda iz elementler ile aynı zamanda bir besin maddesidir de. 1lt. şarap, ortalama 650 kalori vermekte, bu da yaklaşık olarak 900 gr. süt, 370 gr. ekmek, 385 gr. et veya 5 yumurtanın verdiği kaloriye eşdeğer olmaktadır.

Şarapta bulunan mineraller, vitaminler, enzimler vücuttaki madde değiş-tokuşunun düzenli olmasında etkin olduklarından dolayı, solunum organlarına canlılık kazandırır, beyin & diğer organlara olan kan iletişimini hızlandırır, kan dolaşımını düzene sokarlar, böbrek üstü bezlerin çalışma temposunu ayarlarlar, hormon salgılamaya kamçıladiğından vücudun direncini arttırırlar & dolayısıyla soğuk algınlığına & diğer enfeksiyon hastalıklarına karşı vücudu korurlar. **Karaciğer, hergün içilecek 1 lt. şaraptaki alkölü hiç yorulmadan parçalar.** Dozunda içilecek şarap, çağımızın gereği, iş koşulları & çevre sorunları nedenleriyle sinir sistemi harap olan insana ruhi bir zindelik verecek & yaşama olan bağlılığını arttıracaktır. **Bütün içkiler sağlığa zararlı değildir. Şarapta bunun en güzel örneğidir.**

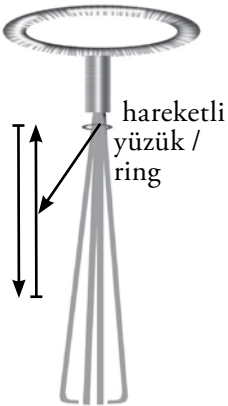
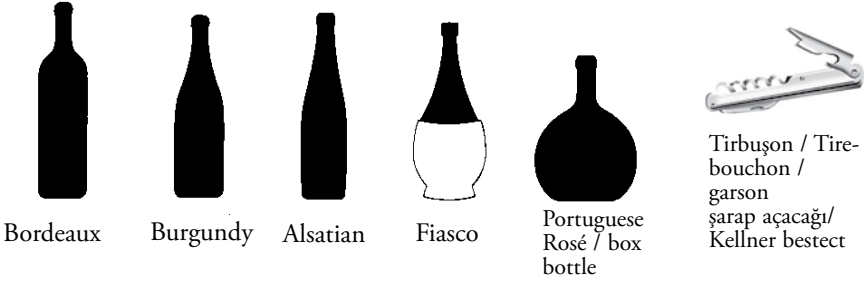

#### message / mesaj:

Profesyonel **à la carte** restaurantlarda, pahalı & kaliteli şarap sipariş verildiğinde garson şarabı açarken mantar kırılabilir. Mantarı çıkaramadığında müşterinin gözü önünde mantarı şişenin içine itmeli. Daha sonra şarap mantar çekicisinin / weinkorkenzieher şişenin içinde hareketli yüzüğünü oynatarak mantarı uç pençesinin içine alır. Yüzüğü aşağı doğru iterek mantarı sıkıştırıp çıkarabilir. Çünkü bazı durumlarda hem şişe hem de mantarı çok değerlidir. Dikkat bu işlem müşterinin gözü önünde yapılmalıdır!

## VİNİEREN / WEINHERSTELLUNG / EAU DE VİE / SUMA

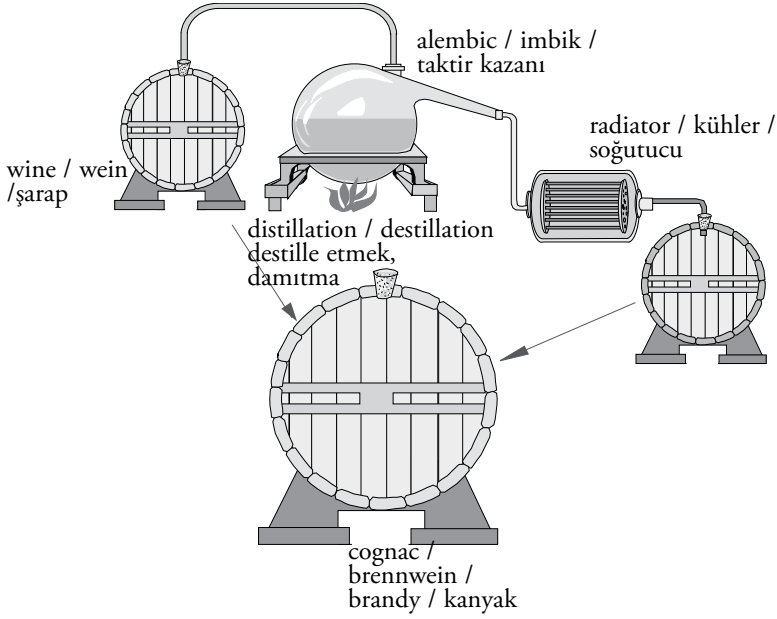

## EAU DİSTİLLE / TAKTİR, DESTİLE EDİLMİŞ

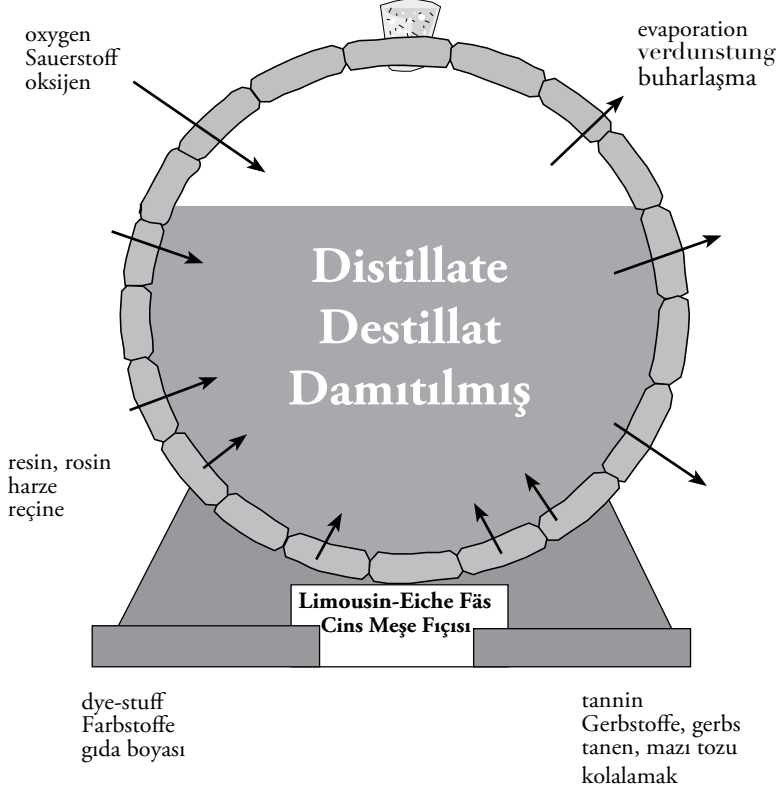

# WINE DIAGRAM / WEINSHEMA / ŞARAP ŞEMASI

## şarabın yapılış yöntemi / vorgang der weinherstellung

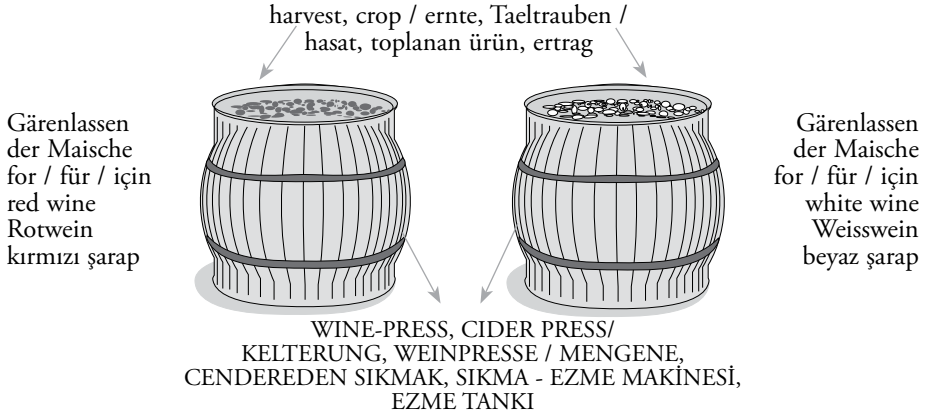

~%20  
(MARC GRAPPA/  
WEINTRESTER/ÜZÜM  
POSASI, CİBRESİ  
TRESTERBRANNTWEIN/  
MARC/MARC BRANDY,  
GRAPPA/AGUARDIENTE DE  
ORUJO)

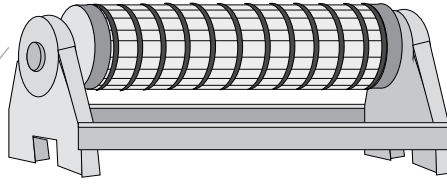

~%80  
GRAPEMUST, CIDER, NEW WINE/  
TRAUBENMOST (SAFT)/  
ÜZÜM ŞIRASI, MEYVE ŞARABI

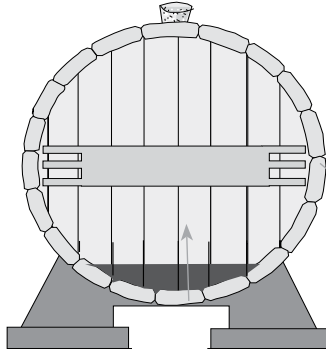

fermentation / Gärung / mayalama / cuvage

wine yeast / weihefe / şarap mayası

to filter, to strain / Filtrierung /  
filtre etmek, süzgeçten geçirmek

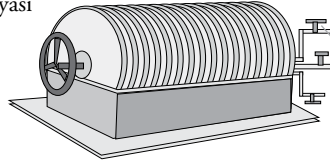

departure, marching to bottled  
Abzug, Abfüllung in flaschen / şişeleme



100 YILDAN ESKİ DAMITMA İMBİKLERİ  
MEHR ALS 100 JAHRE ALTE DESTILLIERKESSEL, KUPFERNEKESSEL / ALEMBIC  
/ İMBİK, DESTILLE KAZANI, DAMITMA KAZANI, TAKDİR KAZANI

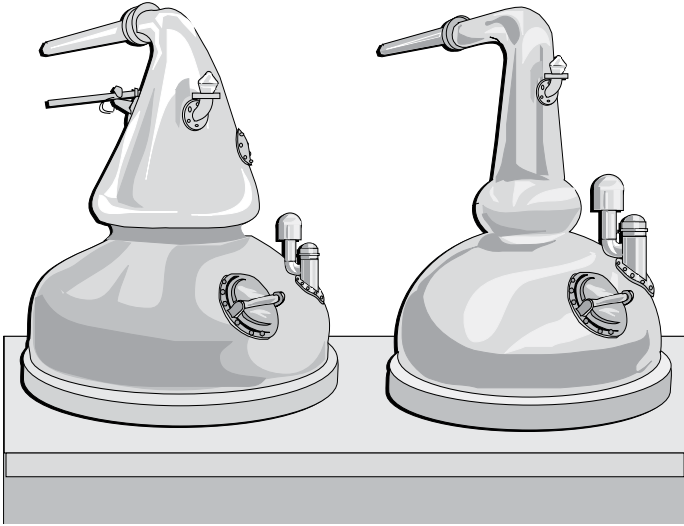
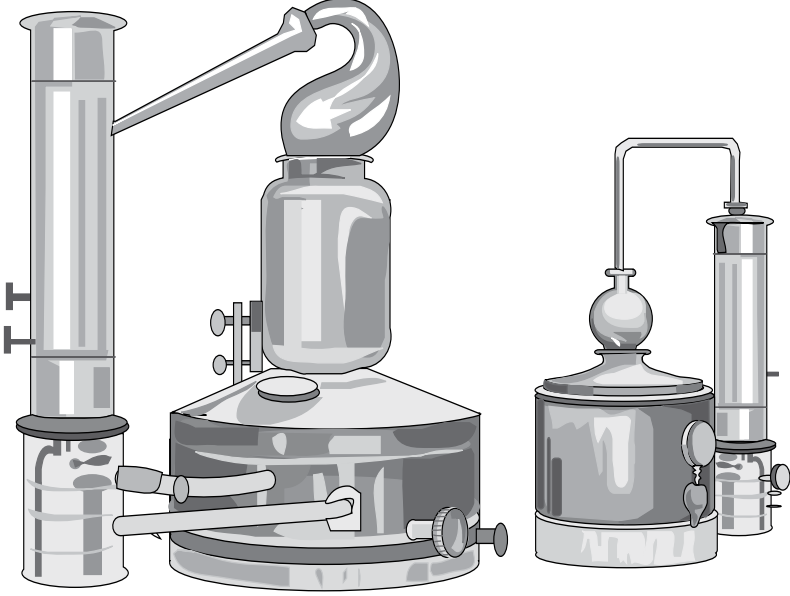

distillation / Destillation / destille etmek, damıtmak  
Alembic / imbik, bakır kazan / Kupfernekessel

### Southern Comfort

Amerikan (bourbon) viski & şeftali, portakal, bitki likörü.

### Sherry

Jerez'in İngilizcesi. jerez dela Frontera Andalusien bölgesinden İspanyol aperatif şarabı (Sherry/jerez/xèrès/şeri).

### Sheridan's

Thomas Sheridan & Sons. / oğulları'nın İrlanda Dublin'de ürettikleri likör. Beyazında; İrlanda viski'li krema / Siyahında; kakao & kahve (Vanilla Cream over, 1/3 / Coffee Chocolate, 2/3) Çok özel bir şişesi olup 2 ayrı bölümlü & kapalıdır.

### Syrup / Sirup / şurup

Koyu bir şerbet, meyve şerbeti ; Şerbetin içine meyve suları, katılarak elde edilir.

### Soft Drinks

Alkolsüz içkiler, (Alkoholfreies Getränk).

### Straight whisky

Amerikan sade / buzsuz / pur / pure whisky. İspirtolu içkiler sınıfındadır.

### Swedish Punch

İsveç yapısı hazır şişelerde bulunan rum/rom punch'ı.

### Slivovits / Sliva / Slibovitza / Schbovitza / (Raki):

Balkan, Serbia & Avusturya yapısı erik & bitki schnaps / Pflaumenschnaps / plumeschnapps / erik rakısı.

### Tabl d'hote

Mevcut, hazır menu / set menu.

### Tequila / Tekila

Meksika'nın ulusal / milli içkisi. Agavenbrand / agaven brendisi (kaktüs benzeri bitkiden damıtılır. Tekila kasabası çevresinde yetişir.) türünün suyundan elde edilir. ispirotolu içkiler sınıfındadır.

### Tequila Olmeca

Agaven schnaps (damatik içki, ispirotolu içki sınıfından).

### Tia Maria

Jamaica kahve likörü.

### Triple sec

Portakal tadında tatlı bir likör, curaçao & cointreau'ye benzer. Portakal likörlerinde kullanılan terim. digestif

### Tiffin

Çay likörü

### Tourist

Tornus, touring, tour, döner / Turcu, turatan, seyahat eden. Bir yerden başka bir yere yalnız gezme, görme amacı ile gidip yiyip, içip konaklayan kişi, kişilere Tourist denir. (Vergnügnungsreisender ein Besucher, der die Nacht über



“konaklayan” bleibt.)

### Travarica

Serbia / Sırp rakısı.

### Tumbler

Ayaksız silindir bardak, (Zylindrishes Glas, ohnefuß)

### Truva / Troy / Toroya

Kaliteli Türk brendisi (brandy).

### Underberg

Alman aromatik / kokulu mide biteri / acısı

### Vermouth / Wermutwein / wormwood / Wermut

Vermut bitkili (wermutkant) likör benzeri şarabı, ana bitkisi pelin otu & çeşitli aromatik/kokulu bitkiler aperitif şarap.

### Vinjack:

Kosova & Serbia/Sırp yapısı brendi.



### Whisky & Whiskey

**İskoçya'da üretilirse "whisky" diye adlandırılır, malttan yapılır**, duman & is kokuludur (peat / torf / kurutulmuş turba yakıtı), **İrlanda'da & Amerika'da üretiliyorsa "whiskey" yazılır, çavdar & mısır' dan yapılır**, kömür tadındadır.

### Whisky / Uisgi

Tahıldan (Wheat / Getreide / blé) destile edilen, damıtılan ispirotolu içki, 3 ayrı yapıdadırlar. **Scotch whisky: Arpa'dan yapılır.** Karakteristik duman, is kokuludur. Amerika'da çavdardan yapılan veya mısırdan yapılan “Bourbon”. Kanada'da **çavdar**'dan yapılan (Rye / Roggen / Single) & arpadan yapılan (barley / gerste / orge) blended /**harmanlı whisky.**

Viskiyi yazmaya kalkarsak şarap brandy & cognac gibi başlıbaşına kitap olur.

### Williams-Christ

Birnenbrand / Armut brendisi.

### Wniztl

Bazı ek çeşitlerinden oluşmuştur destillat değişik çeşitleri vardır. Scotch whisky, gerste den mit karakteri stischem ranhegeschamack çok tutulur, çavdardan (rye / rogggen) yapılmış Amerikan whiskey'i veya mısırdan yapılmış bourbon Kanada whisky'si Canadian whisky diğerlerinden hafiftir, çavdar & arpadan (gerste / barley) yapılır (destilliert).

### Wodka / Votka

Rus & Polonya kornbranntwein (Rusça & Polonyaca anlamı “Wässerchen” küçük su.), patates & mısırdan yapılır, damıtık içki.

### Wu Chia Pi

Çin yapımı darı & gül yapraklarıyla damıtılmış schnaps.

yolluk (bedavacı):

Bazı müşterilerin barlarda / meyhanelerde hesap övendikten sonra istedikleri bedava içki.

Zeste

Portakal veya limon kabuğu (Orangen oder Zitronenschale).



## MIX - LEXICON, DEUTSCH

### ABSINTH

Auch echter Wermut genannt, grünlicher saft des Wurmhohbaumes mit anisähnlichem Geschmack. Wegen seiner schädlichen Nebenwirkungen nicht mehr im Handel. als Ersatz benutzen wir heute Anisbasis mit Lakritz / Süßholz verwendet.

### AGUARDIENTE / Feuerwasser / ateş suyu

Spanische Bezeichnung für Klaren aus Wein.

### AKVAVIT / aquavit / aguvit / aquávit / aqua vitae

Skandinavisches Getreidedestillat mit Kartoffeln & Kümmelzusatz. Das klare bis gelbliche Lebenswasser aus dem hohen Norden ist ein vorwiegend mit Kümmel gewürzter & mit verschiedenen anderen Gewürzen & Kräutern abgerundeter Brantwein. Das Lieblingsversteck dieses harten Skandinaviers ist der Kühlschrank oder besser: die Tiefkühltruhe, denn er will eiskalt getrunken werden & schätzt mit eisigem Hauch gekühlte Gläser. Skáll (aqua vitae: wasser des lebens & köigin aller Arzneien)

### AMARETTO DI SARONNO / acı badem likörü

Italienischer Bittermandellikör.

### AMARO aperitif

Italienische Allgemeinbezeichnung für magenbitter.

### AMER PICON aperitif

Französischer Halbbitter-Aperitif auf Weindestillatbasis, mit Orange, Chinarinde, Enzian & anderen Zusätzen. Wird meist mit Sodawasser verdünnt getrunken.

### ANGOSTURA bitter

Starkbitter; tropfenweise hauptsächlich zur Aromatisierung von Cocktails & Drinks. Aus Kräutern & Gewürzen. Lassen Sie sich niemals auf ein Gläschen Angostura einladen. Es würde Ihnen schlecht bekommen: denn der für seine Bitterkeit bekannte % 40° Brantwein - er wird vorwiegend auf der Basis bitterer Baumrinden hergestellt - ist pur / pure nicht genießbar. Man verwende ihn daher nur wohldosiert - einige Spritzer genügen - als Würze für viele Mixgetränke, aber auch für Speisen.

### ANISGETRÄNKE aperitif

Aromastrake Spirituosen auf Anissamen-Basis, zur Herstellung von Likören, Apéritifs, Digestifs.

ANISETTE            aperitif  
Französischer Anislikör.

APEROL            aperitif  
Italienischer leichter Aperitif Wird meistens als Crusta mit Orangenscheiben zubereitet.

APFELWEIN / elma şarabı/cider/cidre/sidro/sidra  
Frankfurt-Sachsenhausen ist die Hochburg des Apfelweins, sprich äppelwoi oder Ebbelwei. Entweder liebt man ihn - oder nicht. Seine Fans schwören auf ihn - zu jeder Jahreszeit. Auf alle Fälle ist der herbe bis säuerliche Apfelwein (Alkoholgehalt ca. % 5<sup>o</sup>) ein hervorragendes Erfrischungsgetränk an heißen Sommertagen - besonders aufgespritzt mit Mineralwasser.

APERITIFS  
Aperitifs werden in 3 arten unterteilt: 1) Vermouthweine 2) Bitters 3) Anisierte Aperitifs Aperitifs sollten kühl serviert werden. Es sind erfrischende Getränk, die den Appetit anregen sollen & mit oder ohne Wasser serviert werden können.

1) VERMOUTH            10<sup>o</sup>-16<sup>o</sup>-18<sup>o</sup>  
Als Aperitif sehr beliebt ist Südwein aus Italien oder Frankreich: Vermouth dry, bianco oder rosso. Seine besondere Geschmacksnote bezieht er, wie sein Name schon verrät, hauptsächlich aus dem Wermutkraut. Alkoholgehalt des Vermouths 10<sup>o</sup>-18<sup>o</sup>

Die beiden hauptsächlichsten Vermouthhersteller sind Italien & Frankreich. Bereits unsere Vorahren bereiteten einen mit Vermouth vermischten Wein zu. Aber es waren die Italiener, die im 17. Jahrhundert im Piemont (Turin) die Vermouthherstellung im großen Stil aufnahmen. Da die italienischen Weißweine sehr reich an Alkohol & Zucker sind, eignen sie sich besonders gut zur Vermouthproduktion. Um Vermouth herzustellen, läßt man eine Auswahl aromatischer Kräuter in süßen oder trockenen Weißwein ziehen (mindestens 70 % Wein). Die Vermouthwurzel ist Hauptbestandteil, weiter fügt man Chinarinde, Fenchel, Muskat usw. bei. Frankreich seinerseits stellt beachtliche Vermouths aus sehr trockenen Weinen mit großem Alkoholgehalt nach dem gleichen Verfahren her. Der französische Vermouth hat eine hellere Farbe, ist trockener & alkoholhaltiger als der italienische. Man verwendet ihn vor allem zum Mischen von Cocktails. In der Schweiz wird nach italienischen Rezepten ebenfalls ausgezeichneter Vermouth hergestellt.

2) BITTERS  
17<sup>o</sup>-30<sup>o</sup> Wie die Vermouths bestehen die Bitter aus Wein & Wein-geist, in die man verschiedene Alpenpflanzen & Wurzeln einlegt, sowie

Chinarinde, bittere Orangen, Zitronenschale & verschiedene andere Wirkstoffe, die sich durch stärkende & anregende Eigenschaften auszeichnen.

### 3) ANISIERTER APERITIFS 45°

Wie es der Name sagt, werden sie aus Anis (aniseed/anason) hergestellt. Sie ersetzen den Absinth, der verboten ist. Der Alkoholgehalt beträgt 45° & muß auf der Etikette angegeben werden. Anisierte Aperitifs werden immer mit gewöhnlichem, frischem Wasser serviert. Einige Marken. Pernod, Ricard, Berger, Pastis, Raki, Mastika, Ouzo.

### ENZIAN (jenzener) / gentian / centiyane

Dieser Schnaps wird durch das Brennen von Enzianwurzeln hergestellt. Die bekanntesten dieser Schnäpse stammen aus Graubünden, dem Berner Oberland & dem Jura. Ein guter Enzian ist ein ausgezeichnetes Heilmittel bei Magenschmerzen & Verdauungsstörungen. (sindirim bozukluklari) Enzian ist sowohl in Frankreich als auch in Deutschland & Österreich bekannt, aromatischer Magenbranntwein aus den Wurzeln des gelben Enzians.

### KIRSCH (Kirschwasser / schnapps)

Das Nationalgetränk unter den gebrannten Wassern der Schweiz ist der Kirsch, der durch das Brennen vergorener Kirschen gewonnen wird. Die bekanntesten stammen aus Zug, Schwyz, Luzern, Baselland & dem Waadtland. Außerhalb unserer Grenzen ist Kirsch im Elsaß & im Schwarzwald bekannt.

### LIE (Weindrusenschnaps / schnapps)

Lie wird durch das Brennen der weinheferückstände gewonnen.

### LIKÖRE / likörler

Unter Likör versteht man ein geistiges Getränk, das aus Branntwein, der mindestens 10% Zucker & 20% Alkohol enthalten muß, Zuckersirup & aromatischen Wirkstoffen (Früchte, Kräuter, Blumen) hergestellt wird. Die verschiedenen Liköre werden durch die aromatischen Wirkstoffe gekennzeichnet, welche im allgemeinen einfach in die Flüssigkeit eingelegt werden. Hauptlieferanten von Likören sind Frankreich & Holland. Je nach Beschaffenheit & Alkoholgehalt unterscheidet man 3 Arten von Likör: 1) Extrafeine Liköre (extra-fines) 35°-45° 2) Feine Liköre (fines) 25°-35° 3) Gewöhnliche Liköre 20°-30° .

### MARC (weintresterschnaps / schnapps)

Durch Brennen der vergorenen Weintrester (Rückstände der ausgepreßten Trauben) erhält man Marc. Rote Trauben ergeben besseren Marc als weiße. Die

berühmtesten Weintresterschnäpse stammen aus Burgund, Arbois, dem Wallis, Neuenburg & Maienfeld.

### RAKI (aslan sütü-löwen milch-lion's milk) 45°

Internationaler türkischer schnaps / "ähnlich Ouzo" mit Anis (aniseed-anason), gehört zu den spiritosen kategorien, weintrauben, Feige & ähnlich wie Früchte die viel Zucker enthalten zur gerung bringen & mit Anis destilieren. Wasser zufügen. Daneben extra ein glas Wasser servieren. "spirits"

### SLIWOWITZ / SLIBOWITZ (raki)

In Balkan / Serbia & Österreich hergestellter Pflaumenschnapps. Er ist sehr wohlriechend & unterscheidet sich von hiesigen Erzeugnissen durch seine gelbliche Farbe, die er durch die Lagerung im Faß erhält. Prune schnapps, raki / erik rakısı. Besonders in Jugoslawien, aber auch in Österreich & Ungarn, schätzt man diesen % 40 Pflaumenbranntwein. Seine gelbliche Farbe erhält er bei der Lagerung im Faß.

### STEINHÄGER

Dieser Brantwein aus Getreide & Wacholderbeeren wird in Steinhagen in Westfalen (GER.) hergestellt. Er wird als Aperitif oder Digestif genossen, jedoch meistens zu Bier. Sehr kalt servieren.

### GRAPPA

Italienische Bezeichnung für Marc. Grappa wird gewöhnlich mit einer Pflanze, der Raute, aromatisiert, indem man das Kraut in der Flasche ziehen läßt.

### OBSTWASSER

Klar wie Wasser, aromatisch wie ihre Früchte, hochprozentig: das sind die Obstbrände. Destilliert aus Kirschen, Zwetschgen, Aprikosen, Mirabellen, Birnen heißen sie meist Wässer wenn sie aus Beeren, zum Beispiel Himbeeren, hergestellt werden, nennen sie sich gern Geister. Am geläufigsten hiezulande dürften die Schwarzwälder Brennerzeugnisse sein, aber auch österreichische & Schweizer Marken sind bekannt besonders Marillenbrand & Williamsbirne.

### MILKSHAKES

Diese Drinks enthalten, wie der Name sagt, Milch. Einem Shaker werden Eis, 1 Barlöffel Zucker, 12 cl. Milch & die Spirituose geschüttelt, dann in ein schönes Glas abgeseiht. Sie können auch 1 Barlöffel Kaffee- oder Kakaopulver oder einen aromatischen Sirup oder Fruchtsaft dazugeben.





### GLÜHWEIN!!! (mülled claret / mülled wine / sıcak Şarap)

Glühwein kann aus Rotwein oder Weißwein gemacht werden 0,2 l des gewünschten Weines, 2 cl. Zitronensaft, 2 Barlöffel Zucker, 2 Gewürznelken & 1 Stückchen Zimt werden auf kleiner Flamme stark erhitzt, jedoch nicht gekocht.

### PUFFS

Diese einfachen Mischungen bestehen aus Milch, Sodawasser & Alkohol.

### SCAFFAS

Diese italienische Variante des Pousse cafés besteht aus Sirup & mehreren Alkoholsorten.

### TWISTS

In einem Mixglas werden Eiswürfel, 2 Barlöffel Himbeersirup, Saft von 1/2 zitrone, 1 cl. Curaçao, 4 cl. Brandy gemischt & mit Zitronenschale abgespritzt.

### APRICOT BRANDY

Aromatischer Aprikosenlikör.

### ARMAGNAC / Gascogne / F. 18° - 20° digestif

Die Geschichte des Armagnac beginnt 1461, also etwa 200 Jahre früher als beim Cognac. Die Region liegt im Herzen der Gascogne & beherbergt viele kleine Brenner. Dadurch ist es auch noch möglich, die Bestände nach Jahren zu trennen, zu kontrollieren & die Erlaubnis zu erhalten, reine Jahrgangs-armagnacs zu produzieren. Die beste Region ist Bas-Armagnac, dann Ténaréze & Haut-Armagnac. Meistens wird eine Mischung aus allen drei Regionen hergestellt. Armagnac altert sehr gut & ist ein beliebtes Jubiläumsgeschenk.

Französische, geschützte Bezeichnung eines Weinbrandes, dem Cognac ähnlich, welcher ebenso strengen Herstellungsvorschriften unterliegt. Mit unterschiedlichem Aroma je nach Alter & Anbaugebiet. Man serviert ihn in schwenkern/ ballon glas. Er muß gut chambiert sein 18°-20°

Der französische Weinbrand aus der Gascogne unterscheidet sich von seinem bekannten großen Bruder, dem Cognac, nicht nur geschmacklich - bedingt auch durch die verschiedenen Weine, sondern wesentlich durch seinen einmaligen Brennvorgang. Cognac wird nämlich doppelt gebrannt, wobei ein Destillat von etwa % 70° entsteht, während das armagnac-Destillat bei gut % 50° liegt.





### ARQUEBUSE

Starkes französisches Kräuterdestillat.

### ARRAK (reis raki/prinç rakısı)

Starker asiatischer Branntwein. Wird u.a. aus vergorenem Reis, zuckerrohr, Palmsaft, Pflanzensäfte & Melassengärenlassen hergestellt.

### AURUM

Südtalienischer goldfarbener Orangelikör.

### AQUAVIT / akvavit / acquavite / brennendes Wasser

Schnapps aus Getreide, kartoffeln & verschiedenen Gewürzen/kümmel Das klare bis gelbliche Lebenswasser aus dem hohen Norden ist ein vorwiegend mit Kümmel gewürzter & mit verschiedenen anderen Gewürzen & Kräutern abgerundeter Branntwein. Das Lieblingsversteck dieses harten Skandinaviers/ Dänemark/Schweden/Iskandinavya/Danimarka/İsveç ist der Kühlschrank oder besser: die Tiefkühltruhe, denn er will eiskalt getrunken werden & schätzt mit eisigem Hauch gekühlte Gläser. Skål! (Wasser des lebens / yaşamın suyu)

### BACARDI

Markenname für aus Zuckerrohr destillierten weißen & goldfarbenen Rum/rom/rhum/ron (Famile Bacardi/cuba)

### BARACK / palinka

Ungarischer/Macar Aprikosenlikör, Wird aus vergorenen Aprikosen hergestellt. Sehr beliebtes Getränk in Ungarn.

### BATIDA COCO

Brasilianische Bezeichnung für geschüttelte Erfrischungsgetränke liqueur auf Fruchtsaft-Weißrum- Basis. Bekannt sind Batidas auch Kokosnuß, Zitrone, Maracuaia & Ananas. In Europa auch aus Kaffee, Milch & Kakao.

### BÉNÉDICTINÉ D.O.M.

Es ist einer der ältesten französischen Kräuterliköre ( D.O.M. / Deo, Optimo, Maximo. Bénédicte D.O.M.), welches im 16. Jahrhundert in Fécamp in der Normandie von einem der Mönche mit einem im Klostergarten heranwachsenden Kraut hergestellt worden ist. Die Zubereitung dieses Likörs ist strengstens geheimgehalten. Es wird vermutet, dass Thymian, Arnika etc im Herstellungsprozess verwendet wird. D.O.M. steht für Deo Optimo Maximo & bedeutet "alles Große im Namen Gottes". Wenn sich auf den Flaschen ein Kreuz/ † befindet, dann bedeutet dies, dass das ganze Entgelt an die Kirche gespendet wird. Es wurde weiterhin festgestellt, dass die Tiere, die sich von Kräutern, Früchten, Gewächs & Pflanzen des Klostergartens ernähren, süßsauer schmecken.



## BERGAMOTTEN LIKÖR

Aromatischer Likör aus Bergamottebirnen Zitrusfrucht

## BITTERS 17°-30°

Allgemeinbezeichnung für bittere, meist alkoholische Extrakte aus Kräutern, Gewürzen etc. mit breiter Anwendbarkeit in der Mixbar.

## BITTER LEMON

Chininhaltige Limonade als Long drinks basis.

## BOLS

Weltbekannter Markenname, z.B. (örneğın) für Curaçao, verschcrèmes (with cream), Apricot & Cherry Brandy, Weinbrände u.a.

## BOURBON malt & blanded

Etwas nach Karamel schmeckender amerikanischer Whiskey auf Mais-Basis, s.a. Whiskey. digestif

## BIER / bira / beer / birra / cerveza/bière

Hopfen & Malz - Gott erhalt's! Gemeint ist natürlich das Bier, auch Gerstensaft oder flüssiges Brot genannt, Deutschlands Nationalgetränk Nr. 1. & wie der sinnige Wirtshausspruch schon sagt: Gerstenmalz & Hopfen sind die Hauptbestandteile des Bieres, nicht zu vergessen Hefe & natürlich Wasser. Auf das Wasser kommt es nämlich an & dann auf die Kunst des Brauers, der all diese Ingredienzen zu einem köstlich erfrischenden Getränk vereint, das jeglichen Durst besiegt. Ob hell oder dunkel, für jeden Geschmack gibt es das richtige Bier. An erster Stelle sei das meistgetrunkene Vollbier genannt mit einem Alkoholgehalt von etwa % 4°. Es folgen das etwas kräftigere Exportbier & das herbere Pilsener mit seinem charakteristischen Hopfen geschmack. Die Starkbiere mit der Endsilbe ator werden besonders in Bayern geschätzt in der fünften Jahreszeit: der Starkbierzeit, die ebenso starken Bockbiere sind überall heimisch. Das spritzige Weizen oder Weißbier erfrischt bei hochsommerlichen Temperaturen. Dem obergärigen kölsch & dem Düsseldorfer Alt begegnet man fast nur innerhalb ihrer heimatlichen Grenzen & das würzig-süße dunkle Malzbier schließlich mit seinem geringen Alkoholgehalt überläßt der echte Biertrinker lieber seiner Frau... & greift zum ebenso malzigen schwarzen, aber herb-bitteren & käftigen: Stammen aus Irland. 3.5° - 5° im sommer sehr erfrischend.

## BRANDY / branntwein/weinbrand/eau-de-vie/Acquavite/aguardiente/schnapps

Im besonderen versteht man unter Brandy einen Fruchtlikör oder-branntwein beispielsweise Apricot Brandy, im allgemeinen aber einen Weinbrand südlicher Provenienz, aus Italien oder Spanien. Die einzelnen Marken unterscheiden sich vom deutschen Weinbrand oder dem französischen Cognac nicht durch das Brennverfahren, sondern durch die andersartigen, eben südlichen Weine, die den typischen Geschmack eines jeden Brandy ausmachen.

### CALVADOS / apfelbrandy / schnaps / schnapps

Der echte Calvados kommt aus der Normandie, genauer gesagt: ursprünglich aus der Region Calvados, die dem duftenden französischen Apfelschnaps auch seinen Namen gegeben hat. Zweifach gebrannt, erhält er seine Farbe durch Lagerung in Eichenfässern. Kenner schätzen ihn & wissen ein guter Tropfen muß teuer sein. Man trinkt ihn aus Cognacschwenkern. Aus Cidre (apfelwein) gew wonnenes Destillat mit Herkunftsgarantie (Normandie), Alter calvados ist von hoher Qualität & feinsten Eleganz. Als Calvados bezeichnet man das Destillat aus dem Apfelwein, der aus Calvados in der Normandie stammt. Die Lagerung in Eichenfässern vermittelt dem Calvados ein unvergleichlichen Wohlgeruch. (eau de-Vie de Cidre)

### COGNAC / Kognac / kanyak / coñac, Charente / F.

Der weltberühmte französische Weinbrand ist nach der Stadt Cognac in der Provinz Charente benannt & wird ausschließlich aus den Weinen dieser Region gebrannt, deren beste Lagen wie auf dem Etikett vermerk Grande Champagne & Petit Champagne heißen. Unter Fine Champagne versteht man eine Mischung aus Grande Champagne & Petit Champagne. Die meisten Cognacs aber werden nicht aus den Weinen dieser Spitzenlagen hergestellt, sondern aus denen der weniger guten Lagen: Borderies, Fins Bois, Bous Bois, Bon Bois & Bois ordinaire, die untereinander wie auch mit den besseren verschnitten werden. Ihre gleichbleibende Qualität erzielen die einzelnen Marken durch Mischung unterschiedlich alter Brände, deren jüngster die altersangabe auf dem Etikett an gibt. Ein Dreistern-Cognac ist höchstens drei Jahre alt, die Bezeichnungen Réserve, V.O. (Very Old & V.S.O.P. (Very Superior Old Pale) garantieren eine vierjährige, Vieille Réserve & Napoléon eine fünfjährige Lagerzeit. Bei Zimmertemperatur - etwa % 18 & in einem Schwenker oder ähnlichen Glas entfaltet sich das Bouquet des Cognacs am besten. Ist er zu kühl, wärmen Sie das Glas mit der Hand.

### CHAMPAGNER / Sampanya

Er war einmal das Luxusgetränk schlechthin & ist es auch heute noch zwar nicht mehr ganz so exklusiv, doch ein Hauch von High society, High-life & Snob-Appeal umweht ihn stets: Champagner, der, wie sein Name schon verrät, aus der Champagne kommt, dem nördlich-sten Weinbaugebiet Frankreichs, nicht allzu weit von Paris entfernt. Er ist nun mal teuer & kann es sich auch leisten, dieser herrlich schäumende, perlige Wein. Sein Herstellungsverfahren ist aufwendig & kompliziert. Die méthode champenoise unterscheidet sich wesentlich von der Sektherstellung durch die zweite Gärung des Weines: nämlich in der Flasche. Mit der Cuvée, dem Verschnitt verschiedener Weine, werden gleichbleibende Qualität & typischer Geschmack beibehalten. Deshalb schwören Kenner, Liebhaber & Snobs auf ihre Marke. Aber ob man einen brut (äußerst trocken), extra dry / extra sec (sehr trocken), dry / sec (trocken) oder medium dry / demi-sec (halbtrocken) bevorzugt, das ist wohl Ge-



schmackssache.

(BRUT: Sehr trocken als Champagner / very dry, as in champagne)

### GIN / cin

Vor über 250 Jahren reiste der holländische Genever vom Kontinent zum Inselreich England, änderte seinen Namen & wurde zum Gin sank hinab bis in die Gefilde des billigsten Fusels & wurde das beliebteste Gesöff der unteren Volksschichten. Erst vor etwa 100 Jahren wurde er langsam salonfähig & trat seinen Gin wird zwar meistens nur zum Mixen verwendet, weil er sich sehr gut dazu eignet, aber man sollte ihn durchaus auch mal pur genießen.

### GENEVER (cin'in babasi)

Der Holländer, der sich nach dem französischen genièvre zu deutsch: Wacholder benannt hat, ist der Vater des Gin & macht seinem Namen alle Ehre: er besitzt einen ausgeprägten Wacholdergeschmack. Verschiedene Gewürze runden den Getreidebranntwein ab. Man trinkt ihn gern zum Bier & zwar am besten eiskalt. Genever, das Nationalgetränk unter den holländischen gebrannten Wassern, ist ein Getreidebrand, dem vor dem Brennen Wacholderbeeren & verschiedene Gewürze beigemischt werden. Er wird als Aperitif vor oder nach der Mahlzeit als Verdauungsförderer genossen. Auf alle Fälle wird er sehr frisch serviert.

### CACHAÇA

Art von brasilianischem Weißrum.

### CAIPIRINHA

Brasilianisches Erfrischungsgetränk auf Cachaça-Lime-Zucker-Basis.

### \* CAMPARI

Weltberühmte italiensiche Marke, besonders bekannt durch den Bitter Campari.

### CASSIS / cassissée / schwarzer johannisbeere-likör (liqueur)

Französischer Likör aus schwarzen Johannisbeeren.

### CHARTREUSE

Französischer kräuterlikör, grün & gelb, bestehend aus über 100 Zutaten.

### CHERRY BRANDY

Ursprünglich ein englischer Kirschbranntwein. Heute versteht man darunter einen in ganz Europa hergestellten Kirschlikör.

### CHINA

Italienischer bitter/süßer Kräuterlikör aus der Chinarinde.

## CIDRE

Französischer moussierender Apfelwein in den Sorten süß (doux), halbsüß (demi sec) & trocken (sec)

## CINZANO

Italienische Vermouth & Sektmarke, aperitifs.

## \* COCKTAILKIRSCHEN / cocktailcherry / kokteyl kirazi

Für die Cocktailzubereitung werden Maraschino-kirschen verwendet. Sirup, Branntwein oder kandierte (kandiszucker-kandis Şekeri) Kirschen könnten die Geschmacksnuancen eines mixdrinks zu sehr beeinflussen.

## COINTREAU

Weltberühmte französische firma, bekannt durch ihren gleichnamigen Orangenlikör, dem Curaçao ähnlich.

## COLA

Koffeinhaltige limonade mit verschiedenen Aromastoffen & Kohlensäurezusatz. Pur & als long drink-Basis.

## CORDIAL

Früchtelikör auf Himbeer (raspberry / ahududu), Wein & Weindestillat-Bassis, wird einem Reifeprozess unterworfen.

CRÈMES DE ..... Süßstarke Liköre auf Weinbrand basis mit verschiedenen Aroma & Fruchtzusätzen wie z.B: Ananas, Bananen, Curaçao, Café (kahve), Cassis, Framboise, Minthe, Noyaux, Rosen, Vanille, Yvette (Veilchengeschmack) etc. Unentbehrlich für Mixgetränke.

## \* CURAÇAO / (triple-sec).

Der mit dem Namen der Karibikinsel getaufte Likör wird aus den unreifen Schalen der orangenähnlichen Pomeranze gewonnen. Curaçao wird nicht nur als klares Destillat wie ursprünglich, sondern auch farbig angeboten, beispielsweise in Blau oder Orange. Holländischer Pomeranzenlikör. Allgemeinbegriff für Liköre aus der Orangenfamilie Unentbehrlich für viele Mixdrinks; ist erhältlich in blau, grün, gelb, orange & farblos (triple-sec).

## CYNAR

Italienischer Apéritif auf Artischockenbasis. (enginar yapısı bitter).

## DRAMBUIE

Schottischer Whisky, welcher mit Honig & Kräuterzuzügen likörähnliche Konsistenz erreicht, whisky likör.

## DUBONNET

Französischer Apéritif auf Wein, Gewürze-Basis. (temel / yapısı)



EAU DE VIE / Yaşamın suyu / wasser des lebens / water of life / aqua vitae/

Lebenswasser Französische Allgemeinbezeichnung für Branntweine aus Früchten & Beeren.

EIERLIKÖR / yumurta likörü

Likör aus Weinbrand, Eigelb & Zucker. Im Winter gern auch heiß getrunken.

ESCORIAL GRÜN

Würziger starker Kräuterlikör.

FERNET BRANCA

Magenbitter italienischer Herkunft.

FRAMBOISE / Himbeeren / ahududu, ağaç çileği

Himbeere & daraus gewonnene, vielseitig anwendbare Produkte wie Liköre, Sirup & Branntwein. Siegeszug um die ganze Welt an. Nun kam auch der Gentleman in den Genuß dieses klaren Branntweins, der sein Aroma überwiegend aus der Wacholderbeere bezieht, aber auch zur Abrundung seines Geschmacks auf anderen

KORN

Dem eiskalten Klaren, Deutschlands beliebtestem Branntwein, folgt meistens auch ein kühles Bier in manchen Gegenden ein unzertrennliches Gespann. Der mindestens % 32 starke Korn ist ein Getreidedestillat aus Roggen, Weizen, Hafer oder Gerste. Man trinkt ihn pur, verwendet ihn aber genauso gern zum Mixen.

PORTWEIN / PORTO/ fortified wine

Wenn Gäste kommen, schlägt die Stunde des Portweins - des traditionellen Begrüßungsgetränks, besonders bei Überraschungsbesuchen. Die schweren portugiesischen Weine mit einem Alkoholgehalt von etwa % 18 werden in zwei Sorten angeboten. Man unterscheidet in erster Linie roten & weißen Port, sollte aber auch auf Alter & Süße achten. Halbsüß ist im allgemeinen das Prädikat der roten Ports, die weißen können durchweg als trocken (dry) bezeichnet werden, Der porto muß 2 Jahre im Faß altern.

RUM / rhum / rom

Karibik, Westindische Inseln, Jamaika: Heimat des Zuckerrohrs Heimat des Rums. Es scheint, als habe man aus der Not eine Tugend gemacht: aus dem Rückstand der Zuckerfabrikation, der Melasse, wird ein Branntwein gewonnen, der mit unterschiedlich hohem Alkoholgehalt (ab % 40) angeboten wird. Wählen Sie zwischen weißem & braunem Rum der seine Farbe bei der Lagerung in Eichenfässern oder zusätzlich aus gebranntem Zucker bezieht, trinken Sie ihn pur oder gemixt, vielleicht auch heiß: als steifen Grog & Punch



### SEKT / sparkling wine / champagne / şampanya

Gewöhnlich kommt er aus deutschen Ländern, doch auch ausländische Erzeugnisse dürfen sich inzwischen so bezeichnen: Sekt. Der prickelnde, perlende Wein macht munter & beflügelt, eine Medizin gegen Müdigkeit & schlechte Laune. Im Gegensatz zum Champagnerverfahren wird der Wein, ebenfalls ein Verschnitt bei der Sektherstellung erst nach seiner zweiten Gärung z.B. in Großtanks unter Druck endgültig in Flaschen abgefüllt. Handelt es sich aber um eine Flaschengärung, wie beim Champagner, so findet man diese Angabe auch auf dem Etikett. Außer dem gewöhnlichen Sekt werden noch folgende Sorten angeboten: roter & Rosésekt, Jahrgangssekt, Sekt bestimmter Anbaugebiete & Rebsorten.

### SHERRY/Jerez / Xèrès

Jerez de la Frontera der klangvolle Name dieser spanischen Stadt entwickelte sich zum Markenzeichen eines weltberühmten Weines: Sherry. Bei einem Alkoholgehalt um % 18 unterscheidet man gewöhnlich zwei Sorten: süßen & trockenen Sherry, Cream & Fino, wie auf dem Etikett angegeben. Man trinkt ihn gern zur Begrüßung & als Aperitif, & nach 10-15 Jahren erreicht er seinen vollen Geschmack.

### WEIN / wine / şarap

In vino veritas im Wein sei Wahrheit, behaupteten schon die alten Römer & erst recht die Griechen. Der Genuß vergorenen Rebsaftes, das Weintrinken, hat, wie das geflügelte Wort beweist, eine jahrtausendalte Tradition, an der auch Bacchus maßgeblich beteiligt war. Wein das sind Variationen über ein köstlich berauschendes Thema: es gibt roten & weißen, süßen & herben, lieblichen & kräftigen gekeltert aus den verschiedensten Rebsorten. Man trinkt Wein zu jeder Gelegenheit deshalb darf er auch bei einer Sommerparty nicht fehlen. Am besten eignen sich leichte, süffige Weiß & Roséweine kühl serviert, eine angenehme Erfrischung.

Eine gleichmäßige Kellertemperatur ist entscheidende Vorbedingung für die Haltbarkeit. Temperaturschwankungen sind schädlich. Der Keller sollte kühl & nicht zu trocken sein. Mit der Luftfeuchtigkeit hängt die Haltbarkeit der Korken zusammen. Alte Weine sind deshalb so gut wie immer wenigstens einmal umgekorkt worden. Etwa alle 20 Jahre müssen die Korken erneuert werden. Dies übernimmt übrigens auch für Ihre gesammelten alten Weine unsere Weinkellerei, die selbstverständlich hierüber eine Urkunde ausstellt.

Bei alten Spirituosen wird, um die Jahrgangstreue zu erhalten, die verdunstete Menge im Faß durch den gleichen Jahrgang ersetzt. Das ist oft schwierig & hat dazu geführt, daß das Department Cognac schon seit Jahrzehnten auf das Angebot alter Jahrgänge verzichtet. Umso wertvoller sind die noch verfügbaren alten Vorräte geworden.

Daß Wein liegend gelagert wird, ist hinlänglich bekannt, nur Portweine & Sherries werden stehend aufbewahrt, ebenso alle Spirituosen. der Lagerplatz sollte möglichst geruchsneutral sein.





## VİNİEREN / WEINHERSTELLUNG / EAU DE VIE / SUMA

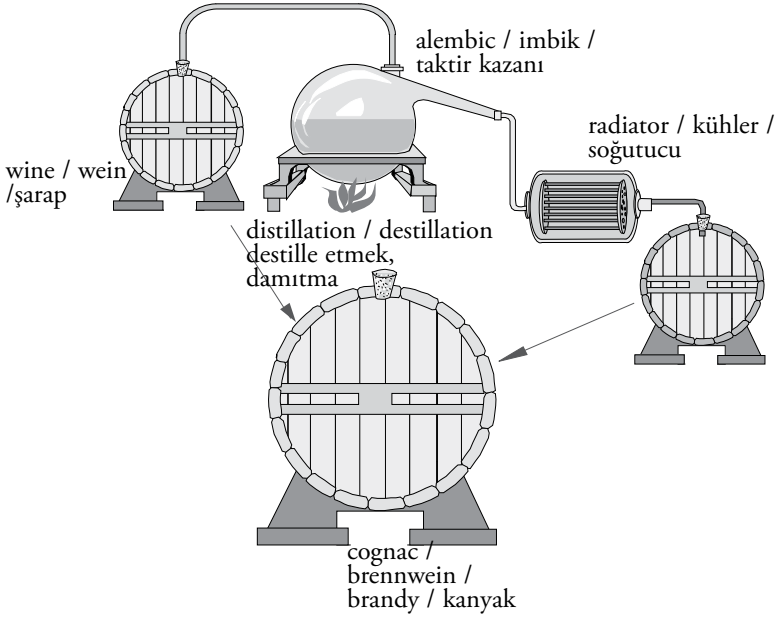

## EAU DISTILLE / TAKTİR, DESTİLE EDİLMİŞ

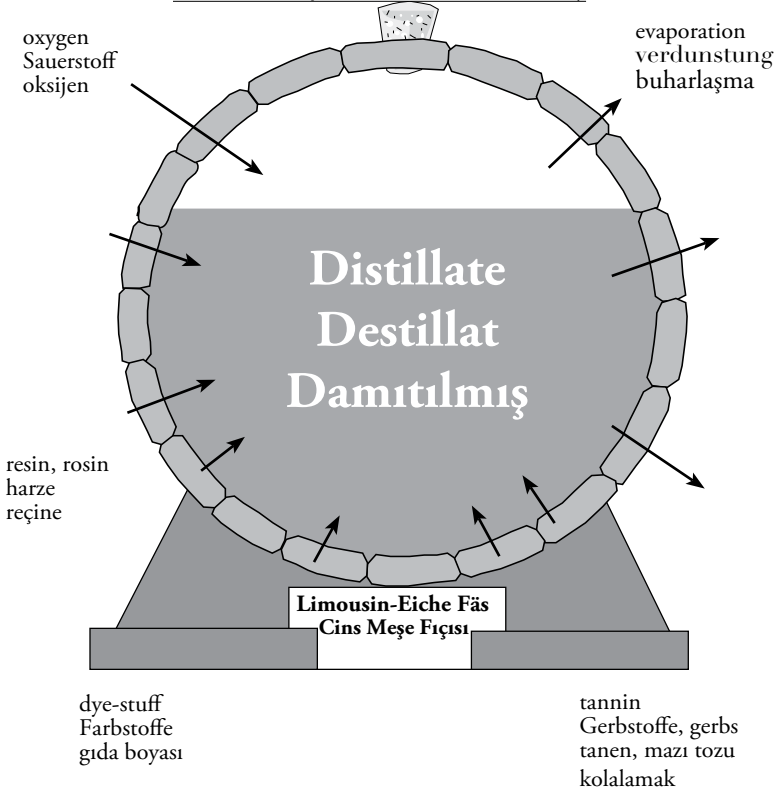

# WINE DIAGRAM / WEINSHEMA / ŞARAP ŞEMASI

## şarabın yapılış yöntemi / vorgang der weinherstellung

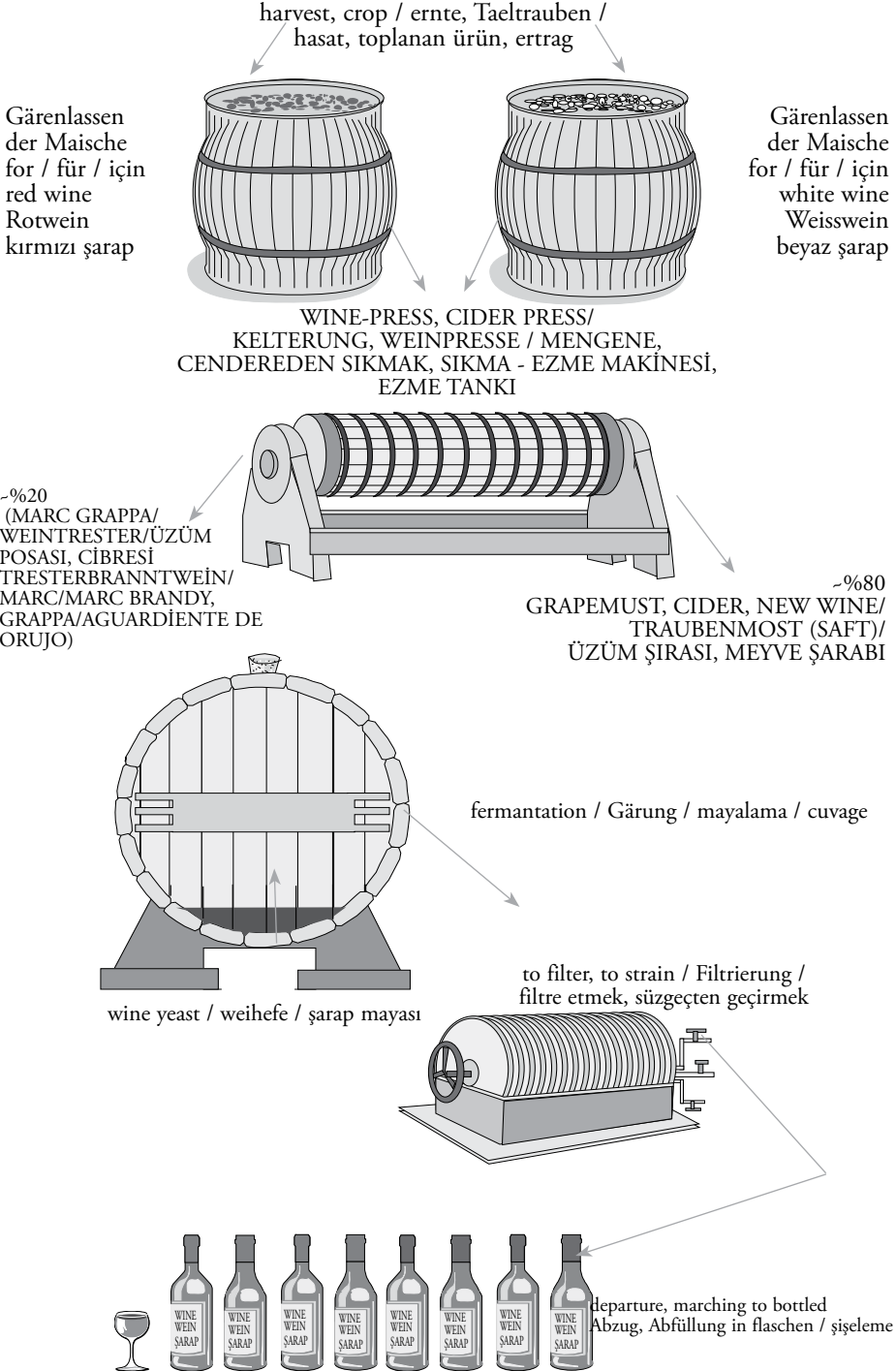

100 YILDAN ESKİ DAMITMA İMBİKLERİ  
MEHR ALS 100 JAHRE ALTE DESTILLIERKESSEL, KUPFERNEKESSEL / ALEMBIC  
/ İMBİK, DESTILLE KAZANI, DAMITMA KAZANI, TAKDİR KAZANI

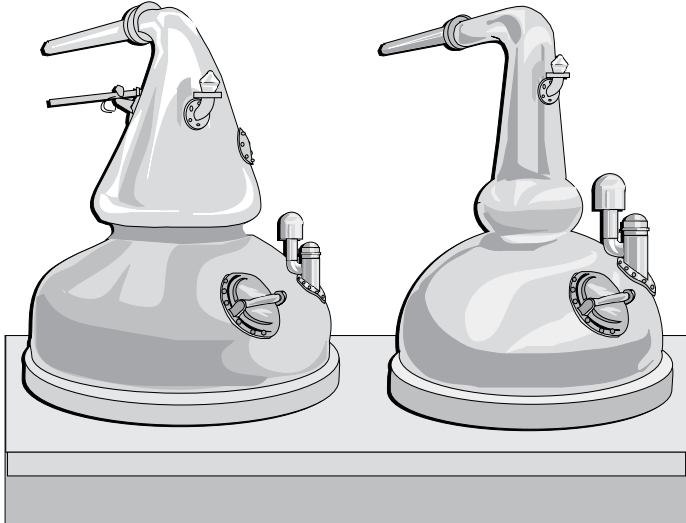
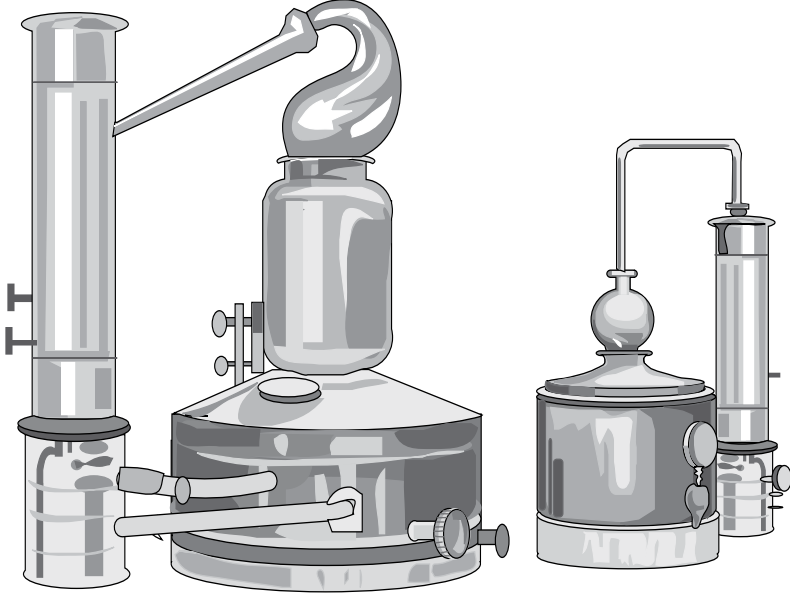

distillation / Destillation / destille etmek, damıtmak  
Alembic / imbik, bakır kazan / Kupfernekessel



Einen alten Wein, den man trinken möchte, muß man dekantieren, d.h. vorsichtig aus der Flasche umfüllen in eine Karaffe, um den ganz natürlichen, entstandenen Bodensatz abzusondern. Das Risiko, daß ein Wein zwischen Dekantieren & seinem Genuß "stirbt" muß freilich in Kauf genommen werden. Eine Garantie für die Haltbarkeit alter Weine kann es deshalb auch nicht geben.

Man sollte die Flasche keinesfalls 2 Stunden vor dem Trinken öffnen. Die richtige Trinktemperatur beträgt bei Weißweinen 12-15°, bei Rotweinen 18-20°.

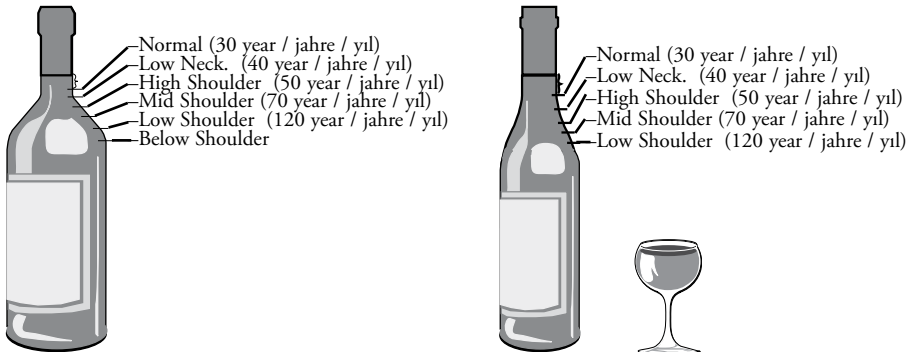

### SPIRITUOSEN / spirits / ispirotolar

Das Geheimnis guter Spirituosen liegt in der Verwendung ausgesuchter Rohstoffe, einer sauberen Brennweise & einer entsprechenden Lagerung. einwandfreie Grundstoffe (Weine, Obst, Getreide, Wurzeln, Gewürze u. a.) ergeben die Grundlage für gutes Aroma, Abtrennung der Fuselstoffe beim Brennen sorgen für die Reinheit, eine längere Lagerung in entsprechenden Gefäßen (Holzfaß, rostfreie Stahlbehälter) für Milde. dadurch entstehen Unterschiede zu billigen Massenprodukten, die sich in der Nase, am Gaumen & im Kopf bemerkbar machen.

### WEINBRAND / BRANDY / COGNAC

#### brennendes wasser / gebrennit win

Auch der große Cognac ist ein Weinbrand, aber fast nur der deutsche Brand aus Wein nennt sich so. Die Weine allerdings, aus denen er gebrannt wird, kommen überwiegend aus Italien & Frankreich, denn deutscher Wein wäre zu teuer. hinter seinen berühmten ausländischen Brüdern muß er sich nicht verstecken, denn er ist bei seinen Landsleuten wie auch international beliebt.

Ausgesuchte Grundweine, doppelte Destillation, um unerwünschte Fuselstoffe auszuscheiden, & gepflegte Lagerung in sauberen Eichenfässern ergeben das Geheimnis eines milden Weinbrands. Alter Weinbrand muß mindestens ein Jahr im Faß lagern, (Deutscher Weinbrand aus deutschen Weinen gebrannt sein.) Die Grundweine für Cognac müssen aus der Region Cognac stammen & auch dort gebrannt werden.

## WHISKY / WHISKEY / uisge Beatha / "hayat suyu" / uisgi / viski

Auch wenn sie alle Whisky heißen, so gleicht doch keiner dem anderen & ein Whisky einem Whiskey schon garnicht! & jeder Whiskytrinker hat seine Lieblingsmarke, selbstverständlich! Für alle Whiskys verbindlich: sie müssen aus Getreide destilliert sein, eine goldgelbe Farbe & einen Mindestalkoholgehalt von 43 % aufweisen. Der kleine Unterschied: jeder Hersteller bevorzugt eine andere Getreidesorte: Gerste, Mais, Roggen oder Weizen.

Der Scotch Whisky ist wohl der bekannteste. Als Blended Whisky wird er aus zwei Sorten verschnitten: aus Malt/Malz Whisky & Grain Whisky (Malz/Malt & Korn Whisky). Die gekeimte Gerste wird über Torffeuern gedarrt daher der typisch rauchige Geschmack, mit Wasser versetzt, vergoren & schließlich destilliert. Dieses Malz-Destillat wird mit einem Brand aus ungemälzter Gerste (Grain Whisky) gemischt & drei Jahre in Holzfässern gelagert. Danach erst wird der hochprozentige Branntwein mit dem guten schottischen Wasser auf Trinkstärke verdünnt, & das sind mindestens 43 %.

Während der Irish Whiskey seinem Nachbarn Scotch in Herstellung & Geschmack ähnelt, hat der amerikanische Whisky seinen eigenen Charakter entwickelt. Whisky made in U.S.A. muß zu mindestens 51 % aus einer einzigen Getreidesorte hergestellt sein: Bourbon Whiskey wird überwiegend aus Mais gebrannt & schmeckt weniger rauchig, der Rye muß zum größten Teil aus Roggendestillat bestehen, der Wheat bezieht sein Aroma hauptsächlich aus Weizen. Der Canadian Whisky erinnert an den Bourbon & last but not least: der deutsche Whisky hat Ähnlichkeit mit dem schottischen.

Ob on the rocks, mit Soda oder pur/pure/sek: über Geschmack läßt sich nicht streiten. Doch pur bei Zimmertemperatur getrunken, da kann der Whisky zeigen, was wirklich in ihm steckt.

Die Kunst der Whisk(e)y-Bereitung liegt in der Auswahl der Rohstoffe, im Mälzen, Darren der Gärung, dem Wasser & der Lagerung im Holzfaß. Die Grundstoffe sind Gerste, Roggen & Mais. Während Schottland & Irland vorwiegend Gerste verwenden, sind es in Kanada Roggen & Mais, in den U.S.A. vorwiegend Mais.

Schottische Whiskys werden als blended Whiskys & als reine Malt-Whiskys hergestellt, irische als blended, ebenso die kanadischen & amerikanischen. Whisky-Spezialisten unterscheiden in Schottland verschiedene Regionen, deren Whiskys unterschiedlichen Charakter haben: Highland, Lowland, Campbeltown, Speyside, Islay (rauchig). Das optimale Alter liegt bei 12 Jahren, reine Jahrgänge dürfen älter sein.

## OBSTBRANTWEINE

Aromatische Früchte mit hohem Zuckergehalt & guter Reife sind die beste Grundlage für einen Brand. Zuckerärmere Früchte werden in neutralen Alkohol eingelegt & gebrannt ("Geiste"). Während Brände durch Lagerung, sowohl im Großbehälter als auch in der Flasche, milder werden, bei gleichzeitiger Intensivierung des Aromas, verändern sich Geiste kaum noch.

Jahrgänge deuten auf besonders günstige Reifebedingungen hin, die es erlauben, einen Jahrgangsbrand zu produzieren. Die Qualität ist dementsprechend hochwertig.

### Wacholder (wacholderbeeren / İngiliz berrak kuş üzümü / ardiç ağacının meyvesi)

Diesen Schnaps erzeugt man, indem man ein Gemisch von Wacholderbeeren & Weingeist destilliert. Der in der Schweiz hergestellte Wacholderbranntwein hat einen sehr ausgesprochenen Wacholdergeschmack. Wacholder ist ein altes Heilmittel der Bergbevölkerung. "Wacholderbeeren (juniper-berry / baie de genèvre / İngiliz berrak kuş üzümü)"

### WILLIAMSBRINEN

Destillat aus vergorenen Williamsbirnen. Sehr beliebtes Getränk im Kanton Wallis (Schweiz).

### WODKA

Das wasserklare Nationalgetränk der Russen & Polen ist schlicht & einfach geschmacklos, geruchlos & vor allen Dingen welche Freude für die Autofahrer! fahnenios. In der deutschen Übersetzung heißt der russische Wodka Wässerchen & die Russen trinken ihn auch so: wie Wasser, aus Wassergläsern, randvoll versteht sich & immer eisgekühlt. Bei uns genießt man ihn ebenfalls pur, aber in kleineren Mengen. Auch zum Mixen eignet sich der Wodka vorzüglich: Mit seiner unaufdringlichen, aber hochprozentigen Neutralität vermag er Fruchtsäfte alkoholisch anzureichern, ohne ihnen dabei ihren typischen Geschmack zu nehmen & im übrigen: Wodka ist kein Kartoffelschnaps, er wird hauptsächlich aus Getreide, Verschiedenen Gewürzen, vorwiegend Weizen, gebrannt.

### ZWETSCHGEN & PFLAUMENWASSER (Pflümlì) / QUETSCHEN / plum / Zwetsch(g)e / mürdüm eriği /

#### Prune / quetsche / Prugna / Criuela

Elsaßische "Elsass-GER." (Alsas-Loren) Bezeichnung für Zwetschge (mürdüm eriği). Andere bekannte Schnäppse aus dem Elsaß & aus Lothringen sind: Mirabelle, Prunelle & Himbeerwasser.

Der Schnaps (schnapps), den man durch Brennen von Zwetschgen & von Pflaumen erzeugt, ist in der deutschen Schweiz sehr beliebt. Er wird dort vor allem unter den Bezeichnungen Zwetschgen & Pflümlìwasser gehandelt.

### FRÜCHTE IN ALKOHOL /alkolde meyveler digestif / digestive / dessert

Erlesene, fleischige & feste Früchte werden in ein Alkohol-Zucker-Gemisch eingelegt & durchtränkt.

Mit Sekt, zum Speiseeis, für den Nachtsch, an Süßspeisen sind sie beliebte Abwechslungen für die gute Küche.

(Örneğin : Williams-Christ-Birnen-Brand "Lachèze" / Brombeeren in Brombeergeist "Schladerer" / Waldbrombeeren in Brombeergeist / Clementinen in Armagnac "Lachèze" / Feigen in Wodka "votkahi incirler")



## BERRY / BEERE / ÇİLEK, DUT-LEXICON

- \* BLACKBERRY: (Brombeere / böğürtlen, dikendudu / Mûre sauvage / Mora di rovo / Zorzamoro)
- \* BILBERRY: (blueberry / Heidelbeere / yaban mersin çileği / Myrtille, airelle / Mirtillo / Arándano)
- \* CRANBERRIES: (Preiselbeer / kırmızı yaban mersini/ mirtillo rosso / arándanes rojos)
- \* CASSIS: (cassissée / Blackcurrant / Schwarzerjohannisbeer / Groseille noire / Ribes nero / Grosella negra / siyah frenk üzümü)
- \* GOOSEBERRY: (Stachelbeere / bektaşi üzümü / Groseille à maquereau / Uva spina / Uva espina)
- \* REDCURRANT (CASSIS): (Roterjohannisbeer / Groseille rouge / Ribesrosso / Grosella roja / kırmızı frenk üzümü, dutu)
- \* MULBERRY: (Maulbeere / dut / Mûre / Mora di gelso / Mora)
- \* RASPBERRY: (Himbeere / ahududu, ağaç çileği / Framboise / Lampone / Frambuesa)
- \* STRAWBERRIES: (Erdbeere / çilek / Fraise / Fragola / Fresa, fresón)
- \* WILD STRAWBERRY: (Walderbeere / yabani çilek / Fraise des bois/ Fragola di bosco / Fresa Sivestre)

## FRUITS / OBST / MEYVELER-LEXICON

- \* APPLE: (Apfel / elma / Pomme / mela / Manzana)
- \* APRICOT: (Aprikose, marillen / kayısı / Abricot / Albicocca / Albaricoque)
- \* AVOCADO: (Avocat / Aguacate / Avukat)
- \* ASSORTED FRUITS: (Gemischtes Obst / karışık meyveler / Frutta mista / Frutas variadas)
- \* BANANA: (Banane / muz / Plátano)
- \* CHESTNUT: (Kastanie / kestane / Châtaigne / Castagna / Castaña)
- \* CANDIED FRUIT: (Kandierte Früchte / meyve şekerlemeleri / fruits confits)
- \* CHERRY: (Kirsche / kiraz / Cerise / Ciliegia / Cereza)
- \* CLEMENTINE: (Klementine, mandarine / mandalina cinsi / Clémentine / Mandarancio, clementina)
- \* COCO-NUT: (Cocosnuß / hindistan cevizi, narsıl / Noix de coco / Noce di cocco / coco)
- \* DATE: (Dattel, lotospflaume / hurma / Datte / Dattero / Datil)
- \* EARLY FRUITS: (Frühobst / turfanda meyveler / Primeurs / Primizie / Primicias; fruta temprana)
- \* FIG: (Feige / incir / Figure / Fico / Higo)
- \* FRESH FRUITS: (Frisches Obst / taze meyveler / Fruits frais / Frutta fresca / Frutas frescas)
- \* GRAPEFRUIT: (greyfurt / Grape-fruit, pamplemousse / Pampelmo / Toronja; pabelo)
- \* GRAPES: (Trauben / üzüm(ler) / Raisin / Uva)
- \* KUMQUAT: (Komquat / kamkat)
- \* KIWI: (Kivi / Rivi)
- \* MANGO: (Mangue)
- \* MEDLAR: (Mispel / muşmula, döngel, beşbüyük / Nèftle / Nespola/ Níspola, níspera)





- \* MELON: (Melone / kavun / Popone / Melón)
- \* ORANGE: (apfelsine / portakal / Arancia, arancio / Noranja)
- \* PEACH: (Pfersich / şeftali / Pêche / Pesca / Melocotón)
- \* PEAR: (Birne / armut / Poire / Pera)
- \* PERSIMMON: (Kakipflaume / hurma benzeri “erik” / Kaki / Cachi / Caqui)
- \* PINEAPPLE: (Ananas / piná, ananás)
- \* PLUM: (Pflaume / erik / Prune / Prugna, susina / Ciruela)
- \* PLUM: (Zwetsch(g)e / mürdüm eriği / Prune, quetsche / Prugna / Ciruela)
- \* POMEGRANATE: (Granatapfel / nar / Grenade / Melagrana / Granada)
- \* PRUNE: (Backpflaume / kuru erik / Pruneau / Prugna secca / Ciruela pasa)
- \* RAISINS: (Rosinen / kuruüzüm / Raisins sees / Uva passa / Pasas)
- \* SULTANAS: (Sultanien / çekirdeksiz izmir kuru üzümü / marasca / Guinda / Risins de Smyrne / Sultanas / Uva sultanina / Pasas de Esmirna)
- \* SOUR CHERRY: (Sauerkirsche / vişne / Griotte / Amarena, visciola, marasca / Guinda)
- \* TANGERINE: (Mandarine / mandalina / Mandarino / Mandarina, tangerina)
- QUINCE: (Quitte / ayva / Coing / Cotogna, mela cotogna / Membrillo)
- WATER-MELON: (Wassermelone / karpuz / Pastèque, melondèau / Cocomero, anguria / Sandía, melón de aqua)
- \* YELLOW PLUM: (Mirabello / küçük sarı erik / Mirabella “sorta di susina” / Ciriela amarilla)

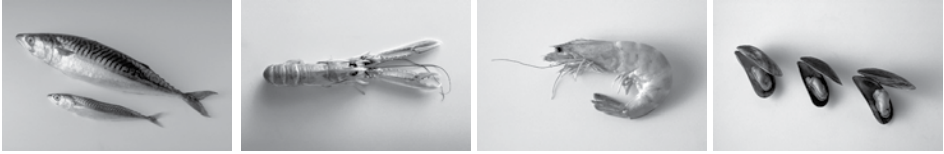

## FISH / BALIK-LEXICON

(SEA FISH / SEEFISCHE / POISSON DE MER / SALTVANDFSISK)

(LANGUAGES: TUR, D, DK, F, FA, GB, I, IS, J, N, NL, P, S, SF, SP)

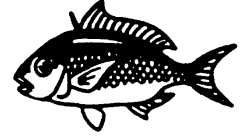

01-Köpek balığı “max.1200 cm.” (Riesenhai, Basking Shark, Requin pèlerin, veau de mer, Brugda, Squalo elefante, Beinhákarl, Ubazame, bakazame, Brugde, Reuzenhaai, Peixe-frade, Brugd, Jättiläishai, Peregrino)

02-Batos “max.100 cm.” İğneli, düğmeli (Nagelrochen, Thornback Ray, Sømrokke, Raie bouclée, Naglasköta, Razza chiodata, Drönfuskata, Gangiei-no-rui, Piggs skate, Stekelrog, Raia-pinta, Knaggrocka, Okarausku, Raya de clavos, raya común)

03-Batos “max. 250 cm.” Düğmesiz (Glattrochen, Skade, Pocheteau blanc, Sköta, Common Skate, Razza bavosa, Skata, Gangiei-no-rui, Storskate, glattrokke, Vleet, Airoga, Slätrocka, Silorausku, Raya noruega)

04-Sokkan “max.50 cm.” (Seehase, Lumpfish, Lump sucker, Stenbider, Lompe, Rognkelsi, Sea-Hen, Ciclottero, Hrognkelsi, Dango-uo, Rognkjeks fem., rognkall male, Snotdolf, Galinha-do-mar, Sjurygg, stenbit, kvabbsö, Rasvakala)

05-Mersinbalığı “max.600 cm.” siyah havyar çıkararı (Gemeiner Stör, Sturgeon, Esturgeon d'Europe, Stör, Styrja, Storione, Styrja, Chozame, Stør, Steur, Esturjão solho, Stör, Sampi, Esturión)

06-Kordele, Kurdele “max.700 cm.” (Riemenfisch, Oarfish, King of the Herrings, Roi des harengs, Sildekonge, Regaleco spada, Sildarkóngur, Ryukyunotsukai, Sildekonge, Haringkonging, Sillkung, Airokala)



07-Kırlangıç “max.75 cm.” (Roter knurrhahn, Rød knurhane, Grondin perlon, Yellow Gurnard, Capone gallinella, Knúrri, Hobo-no-rui, Rødknurr, Rode poon, Bacamarte, Fenknot, Isokurnusimppu, Bejel)

08-Öksüz balığı “max. 45 cm.” (Grauer Knurrhahn, Grey Gurnard, Grondin gris, Grå knurhane, Grondin gris, Capone gorno, Urrari, Hobo-no-rui, Knurr, Grauwe poon, Ruivo bacamarte, Knorrhane, knot, Kyhmykurnusimppu, Borracho, perlon)

09-Deniz Turnası “max.35 cm.” (Grosser Sandaal, Tobiskonge, Grand Lançon, Stóra nebbasild, Greater Sandeel, Cicerello, maggiore, Trönusilí, Ooikanago-no-rui, Storsil, Zandaspiering, smelt, Galeaota, Tobiskung, Isotuulenkala, Pión)

10-Levrek “max. 100 cm.” (Wolfbarsch, Seebarsch, Havbars, Bar commun, Bass, Sea Perch, Spigola, branzino, Vartari, Suzuki-no-rui, Havåbor, havabbor, Zeebaars, Robalo, perca, Havsabborre, Meribassi, Lubina.)

11-Köpek balığı “350 cm.” (Heringshai, Sildehaj, Requin commun, taupe, Hemari, Porbeagle, Smeriglio, Hámeri, Nezumizame, Hábrann, Neushaai, Anequim, sardo, Hábrand, silhaj, Sillihai, Cailón marrajo.)

12-Pisi “max.75 cm.” (Glattbutt, Slethvarre, Barbue, Brill, Kite, Rombo liscio, Slétthverfa, Hirame, karei-no-rui, Slettvar, Griet, Rodovalho, parracho, pegadeira, Slätvar, Silokampela, Rémol.)

13-Zargana “max. 80 cm.” (Hornhecht, Hornfisk, Orphie commune, Garfish, Garpike Aguglia, Hornfiskur, Datsu, Horngjel, Geep, Peixe-agulha, Näbbgädda, Nokkakala, Aguja.)

14-Kaya balığı “max. 50 cm.” (Aalmutter, Ålekvabbe, Loquette d’Europe, Eelpout, Blenio viviparo, Mjõsi, Ginpo-no-rui, Ålekvabbe, Puitaal, Tånglake, Kivinilkka.)

## message / mesaj :

Chief Adnan **Mert**, gözlerinizin önünde akvaryumdan canlı balığı alıp çabucak ayıklayıp önceden hazırlanmış (mise en place / vorbereitung / ön hazırlık) kızgın soslu yağda kızartıp önünüzdeki tabağa koyar & buyrun afiyet olsun der, ama yiyemezsiniz, çünkü balık hala canlıdır !

Aklınızda haydi be öyle şey olur mu ? diye geçiriyorsanız, inanmıyorsanız !

Türk.-deu. info.:+ 90. 533. 321 83 28

Eng. info.: +90. 534. 325 75 87

## **Message / mesaj**

Türkiye' deki hotel, restaurant, bar işletmelerinin dikkatine!

İstek üzerine Adnan **Mert** bar & service eğitim seminerleri verilmektedir.

**Info. :** + 90.533.321 83 28

barantico@barantico.com.tr

adnanmert16@hotmail.com

www.barantico.com.tr



## SPIRITS / SPIRITUOSEN - LEXICON

### LIQUEURS / LİKÖRLER / LİKÖRE

#### \*\* MEYVE SULU-LİKÖRLER / FRUCHTSAFT-LİKÖRE:

(\*\* gıda boyasız, \*\* renk maddesiz / \*\* ohne Farbstoff)

	şişe
	% VOL. bottled / flaschen
Böğürtlen (dikendutu / Blackberry / Brombeeren / mûre sauvage / Mora di rovo / Zarzamora)	
• Chambord Liqueur Royale de France – % 16.5	0.50 l.
***	
Yabani çilek (wildstrawberry / Walderdbeeren / Fraise des bois / Fragola di bosco / Fresa Sivestre)	
• Vedrenne Crème de Fraise des Bois — % 20	
***	
Yaban mersini çileği (Bilberry, blueberry / Heidelbeeren / Myrtille, airelle / Mirtillo / Arándano)	
• Ettaller Heidelbeerlikör mit kräutern — % 25	0.50 l.
***	
Ahududu (ağaç çileği / raspberry / Himbeeren / Framboise / Lamponi Frambuesas)	
• Védrenne Crème de Framboise — % 18	
• Marie Brizard Framboise — % 20	
***	
Cassis (cassissée / schwarzer Johannisbeer / Frenk üzümü / groseille noire / Blackcurrant / Ribes nero / Grossella negra)	
• Védrenne Crème de Cassis — % 20	
***	
Kiraz (cherry / kirsch / cerises / ciliegia / cerezas)	
• Cherry Herring — % 25	0.50 l.
• Bols Prinzenkirsch — % 25	
***	
Maracuja	
• Riemerschmid Känguruh (kangaroo / kanguru) — % 18	

#### MEYVE ARAMOLI - LİKÖRLER/ FRUCHTAROMA-LİKÖRE:

(meyvenin etli kısmından damıtılmış / aus dem Fruchtfleisch destilliert (ohne künstliche Aromastoffe))

Kayısı (Apricot/Aprikose/Marillen/Abricot/Albicocca/Albaricoque)	
• Bols Aprikot — % 29	
• Marillenlikör Freihof/AUS. — % 25	0.50 l.



- Marillenlikör Freihof/AUS. ————— % 25      0.25 l.
- Marie Brizard “Apry” ————— % 30

\*\*\*

Muz (Bananas / Bananen / Plátano)

- Marie Brizard Crème de Banane ————— % 25

\*\*\*

Armut (Pear / Birne / Poire / Pera)

- Morand Williams-Birnenliqueur ————— % 35

\*\*\*

Curaçao (bitterorange / acı portakal cinsi “Antil Adası Curaçao”)

- Bols Blue Curaçao (\* gıda boyalı) ————— % 30
- Bols Dry Orange Curaçao ————— % 35
- Bols Curaçao Triple sec ————— % 39

şise

% VOL.    bottled / flaschen

İncir (Fig / Fiegen / Figure / Fico / Higo)

- Riemerschmid Askalon Feigentrunk ——— % 32

\*\*\*

Kiraz (Maraschino / Cherry / Kirsche / Cerise / Ciliegia / Cereza)

- Dallmayr maraschino ————— % 35
- Dallmayr Maraschino ————— % 35      0.35 l.
- Luxardo Maraschino ————— % 32      0.50 l.

\*\*\*

Kavun (Melone / Popone / Melón)

- Cartron, französischer Melonenlikör ——— % 18

\*\*\*

Portakal (Apfelsine / Arancia, orancia / Maranja)

- Maria Brizard Orangero ————— % 38
- Aurum-Italian Golden Orange Liqueur — % 40

\*\*\*

Şeftali (Pfirsich / Pêche / Pesca / Melocotón)

- Maria Brizard Peach ————— % 30
- Cortron Creme de Pêche de Vigne ——— % 18  
aus Burgunder-Weinbergspfirsichen

\*\*\*

Turunç (Bitter Orange / Pomaranze)

- Mampe Grüne Pomaranze ————— % 37      0.50 l.

\*\*\*

Kırmızı yaban mersini (Cranberry, cowberry / Preiselbeeren)

- Lapponia-Puolukka ————— % 28      0.50 l.

\*\*\*

Ceviz (Walnut / Walnüsse / Walnuß)

- Lantenhammer Bayer. Walnußlikör ——— % 30



## MEYVE BRENDİ LİKÖRLERİ

### FRUCHTBRAND LİKÖRE:

(Mevsimlik kaliteli meyvelerden hazırlanan / mit Edelbrand der jeweiligen Frucht zubereitet)

Kayısı (Apricot/Aprikosen/Marillen/ Abricot / Albicocco / Albaricoque)

- Schladerer Aprikot ————— % 30

## BAHARAT - BİTKİ & BİTTER LİKÖRLER

### GEWÜRZ -, KRÄUTER, & BİTTER LİKÖRE:

Anason (Anise / Aniseed / Anice)

- Sambuca Molinari ————— % 40
- Marie Brizard Anisette ————— % 25
- Kümmel (kummel / cúmel) “caraway & anise seeds likör / liqueur”
- Gilka Kaiser-Kümmel ————— % 38      0.50 l.

Peppermint (nane yaprakları / pfefferminze / menthe (poivrée / menta / hierbabuena)

- Maria Brizard Peppermint Green ————— % 25

Kräuter (bitki / herbes, fines herbes / herbs)

- Benedictine D.O.M. ————— % 40
- Chartreuse jaune (gelb, yellow, sarı) ————— % 40
- Chartreuse verte (grün, green, yeşil) ————— % 55
- Chartreuse jaune (gelb) VEP extra alt ————— % 42      1.0 l.  
im Holzfaß gelagert
- Chartreuse verte (grün) VEP extra alt ————— % 55      1.0 l.  
im Holzfaß gelagert
- Liqueure Galliano ————— % 35

şişe

---

% VOL.    bottled / flaschen

Feinbitter

- “Der Lachs” Kurfürstlicher Magenbitter — % 38      0.50 l.
- Mampe Halb & Halb ————— % 33
- Amaro Ramzotti, der Halbbitter aus Italien % 30
- Karlsbader Becher Kräuter-Spezial ————— % 38
- Elixir d’Anvers, belg. Kräuterlikör ————— % 37
- Cointreau Gold ————— % 40

Bittere (Bitters / Acılar)

- Dr.Siegert’s Angostura Bitter ————— % 44      200 ml.
- Dr.Siegert’s Angostura Bitter ————— % 44      100 ml.
- Ettaler Magenbitter ————— % 45      0.50 l.
- Chiemseer Magenbitter ————— % 38
- Averna, sizil. Bitter ————— % 34
- Fernet Branca alla Menta ————— % 40
- Fernet Branca Magenbitter ————— % 42
- Appenzeller Alpenbitter ————— % 30

Vanille (Vanilya)



- Licor 43 Cuarenta y tres ————— % 34  
spanischer Kräuterlikör mit Vanille  
(\* gıda boyalı / \* dye-stuff / \* mit Farbstoff)

### BAYERISCHE LIKÖRSPEZIALITÄTEN /

#### SPESİAL BAVYERA LİKÖRLERİ / BAVARIAN SPECIAL LIQUEURS:

- Ettaler Klosterlikör, herb ————— % 42      0.50 l..
- Ettaler Klosterlikör, gelb ————— % 40      0.50 l..
- Chiemseer Halbbitter ————— % 38
- Chiemseer Klosterlikör ————— % 38
- Riemerschmid Escorial Grün ————— % 56

### COCOA LIQUEURS / KAKAO LİKÖRE / KAKAO LİKÖRLERİ:

- Bols Crème de Cacao, braun ————— % 27
- Bols Crème de Cacao, weiß ————— % 27

### COFFEE LIQUEURS / KAFFEE LİKÖRE / KAHVE LİKÖRLERİ:

- Dallmayr Dyawa Mokka ————— % 28
- Kahlua, mexikanischer Kaffeelikör ——— % 26,5
- Tia Maria, Jamaica Coffeeliqueur ——— % 31

### CHOCOLATE LIQUEURS / SCHOKOLADEN LİKÖRE /

#### ÇİKOLATA LİKÖRLERİ

- Marmot Chocolat Suisse ————— % 25  
mit Schokoladenstücken

### EGG LIQUEURS / EIER LİKÖRE / YUMURTA LİKÖRLERİ:

- Dallmayr Eierlikör ————— % 20
- Dallmayr Eierlikör ————— % 20      0.35 l.

### DIVERSE LIQUEURS / VERSCHIEDENE LİKÖRE / DEĞİŞİK LİKÖRLER:

- “Der Lachs” - Danziger Goldwasser ——— % 40      0.50 l.
- Ameretto di Saronno - Mandellikör ——— % 28  
in Luxus-Dekanter-Muranoglasflasche
- Liqueure Galliano ————— % 35

	% VOL.	şise bottled / flaschen
• Cointreau —————	% 40	
• Cointreau —————	% 40	0.35 l.
• “Lou Flouret” Liqueur à l’Orange D’Armagnac	% 25	



- Mozart-Liqueur ————— % 20  
Österr, Nougat-Likör aus Salzburg
- Bärenjäger (Honiglikör Bal likörü) ——— % 35
- Campari Cordial - Himbeergeistlikör — % 36
- Irish Mist Whiskylikör / Viski likörü—— % 35
- Drambuie Prince Charles Edward's Liqueur % 40
- Prunelle à la Fine Bourgogne———— % 35  
(Schlehenliqueur mit Weinbrand)
- Southern Comfort, Whiskey-Likör aus USA % 40
- Grand Marnier Cordon Rouge ————— % 40
- Grand Marnier Cordon Rouge ————— % 40
- Sabra-israelischer Schoko-Orangenlikör— % 30
- Grand Marnier Cuvée de Centenaire—— % 40
- Grand Marnier Cuvée Speciale ————— % 40  
Cint Cinquantenaire
- Ratzeputz auf Ingwerbasis ————— % 58

0.35 l.

### LEICHT - ALKOHOISCHE GETRÄNKE:

- Whiskey Lime - Likör aus abgelagertem Scotch% 18
- Bailey's Original Irish Cream———— % 17  
Irischer Sahne-Whiskey-Liqueur
- Whiskey Pêche - Likör aus abgelagertem Scotch% 18  
& weißen Pfirsichen
- Pecher Mignon ————— % 18  
Pfirsichaperitif aus weißen Pfirsichen
- Cocaribe, Wild Island Coconut———— % 21  
mit Virgin Island-Rum
- Monin Triple Lime ————— % 21

### YAK-LIKÖRE / PROVENCE / F.:

From fine cream with naturell fruit & vegetalnectar  
Aus feinsten Sahne mit natürlichen Frucht & Pflanzenextrakten  
İnce kremadan

- mit / with / ile Walderdbeere (wildstrawberry / yabani çilek /  
Fraise des bois / Fragola di bosco / Fresa Sivestre) % 15
- mit / with / ile Vanille-Zimt / cinnamon / tarçın % 15
- mit / with / ile Kakao-Noisette ————— % 15
- mit / with Kakao (cocoa) - Café (kahve / coffee) % 15

### TAHIL / GRAIN, WHEAT / GETREIDE / BLÉ - LEXICON

ARPA: (Barley, Gerste, orge)  
BUĞDAY: (Wheat, Weizen / froment)  
MISIR: (Corn, maize, maïs)  
ÇAVDAR: (Rye, Roggen, Sigle)



YULAF: (Oats, Hafer)  
PİRİNÇ: (Rice, Reis)  
KÖK: (Root, Wurzeln)  
MALT: (Malt, Malz)  
KORN: (Tahıl, hububat, ekin, başak, peygamber çiçeği)  
BAHARAT: (Spice, Gewürz)  
DARI: (Millet, Hirse)

## TURKISH LIQUEURS / TÜRKISCHE LIKÖRE / TÜRK LIKÖRLERİ

digestifs

01-PORTAKAL	.....	orange (Curaçao)
02-MANDALİNA	.....	tangerine (Crème de mandarine)
03-LİMON	.....	lemon / zitrone / citron
04-MENTHE	.....	(nane) / peppermint Crème de menthe
05-BEĞENDİK	.....	(bitki) / plant
06-TURUNÇ	.....	Seville orange
07-BİNDALLI	.....	Seville orange
08-KAYISI	.....	apricot (apricot brandy)
09-GÜL	.....	rose (Crème de rose)
10-AHUDUDU	.....	raspberry (Crème de framboise)
11-ÇİLEK	.....	strawberry (Crème de fraise)
12-VİŞNE	.....	cherry brandy
13-KAKAO	.....	cocoa (Crème de cacao)
14-MOKKA	.....	(kahve) / coffee (Crème de mocca)
15-MUZ	.....	banana (Crème de banane)
16-ALTIN	.....	gold (Liqueur d'Or / Gold Wasser)

## FRAPPES & GLACÉS

İsminden de anlaşılacağı gibi, bu içkiler çok soğuk içkilerdir. Bu içkiler kırık buz üzerinde servis edilir. Frappe'lerde 4 cl. istenilen alkolü içkiyi (Champagner / Sekt / Sparklings Wine, şarap bardağına doldurulur, küçük buz parçacıkları (cracked ice) konur & bir pipet ile servis edilir. Tercih edilen Frappe'ler naneliler, Apricot (kayısı) Brandy & Cointreau'dur.

## MILCHSHAKES (SÜT KARIŞIMI) (sh.)

Bu içkilerde, isminden belli olduğu gibi süt bulunur. Bir shaker'in içine buz, 1 bar kaşığı şeker, 12 cl. süt & alkolü içkiyi (spirits / spirituousen) döküp çalkalayın & güzel bir bardağa süzün. İstek üzerine bir bar kaşığı kakao, kahve, aromatik şurup veya meyve suyu kullanabilirsiniz.







## SICAK ŞARAP / GLÜHWEIN / MULLED CLARET / MULLED WINE

(Vin chaud / Vino br  l  , vino caldo / Vino caliente

Isıtılmıř řarap kırmızı veya beyaz řaraptan yapılabilir. 0.2 l. istenilen řarap, 2 cl. limon suyu, 2 bar kařığı řeker, 2 karanfil & bir para tarın hafif bir ateřte ısıtılır, fakat kaynatılmaz.

## PUFFS

Bu basit karıřımlar s t, soda & alkolden yapılır.



## LUMUMBA

4 cl. Brandy, kakao, 1 yemek kařığı krema, toz kakao, Brandy'yi bir high-ball-Glass'a / High-ball bardađına koyun, kakao ile doldurun,  zerine biraz krema & toz kakao serpiniz.

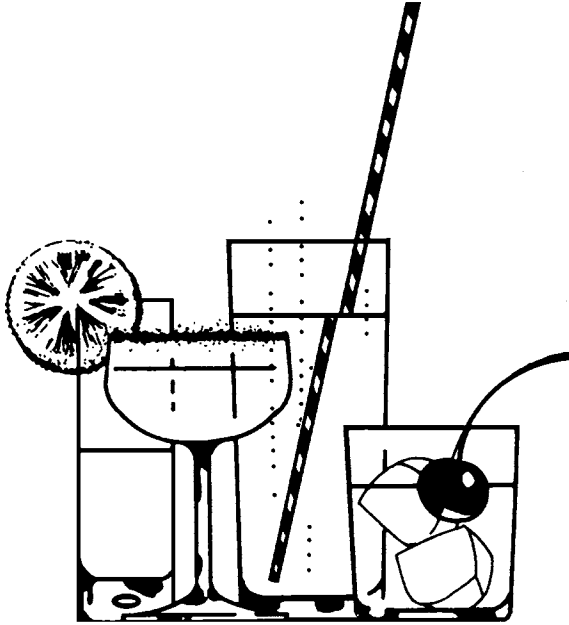

## Kütüphane / Library / Bücherei / Bibliothek-LITERATUR

**à la carte** / garson hizmeti ile yapılan servis

**arnavut böreği (Pita) / Ispanaklı** veya **pırasalı** hazırlanır, balkanlardan göç eden Osmanlı halk / mutfak / sofrta kültürüdür. "sofra: sefer, yolculuk, yiyecek torbası." Anneden kızına (yoksa gelinine) icazet / el verme usulü ile günümüze kadar gelebilen nadide damak zevkidir. Sevgili anneler lütfen bu eşsiz mutfak kültürünüzü devam ettiriniz. Bu kültürünüz yok olmasın. Çünkü restaurantlarda, börekçilerde yapılan börekle eş değer değildir.



**arnavut mantısı/ Kıymalı** yapılır, hazırlanışı aynı arnavut böreği gibi olup hamur açıldıktan sonra, kareler şeklinde kesilip içine kıyma harcı konulur. Bohça şeklinde kapatılır. Bu mantı tatar mantısı / tabak börek gibi değildir. İcazet / el verme usulü ile günümüze kadar gelebilen nadide damak zevkidir / sofrta kültürüdür.

**aroma** (bukett / bouquet / koku, buke'si / flavouring, arôme / Duft)

**anise** (aniseed / anis / anason / anice )

**anretning / entrée** (çorbadan sonraki ilk servis / erster gang nach der suppe / first course / deuxi ème service / secondo piatto / segundo plato)

**ayran** (butter milk / yoghurt drink)

**banquet** (bankett/banchetto/banquete) "şölen, eğlence, ziyafet"

**bistro/Fransız usulü bar**("pub" ise İngiliz usulü bardır, "bar American" ise Amerikan usulüdür.

**bitter** (acı / amer (f.amère) / amaro / amargo)

**bitter orange** (pomaranze / acı portakal)

**bread roll** (semmel/petit pain / panino / panecillo / ufak yuvarlak ekmek / hamburger v.b.)

**brandy** (brendi/schnaps/Eau-de-vie/acquavite/Aguardiente/weinbrand)

café (kahve,kahvehane/kafenio,kafenes/café turc/kaffee house/coffee house)

**Buchón** "buşon" (müşterinin dışarıdan getirdiği extra içkiye verilen bir maliyet/ service fiyatı.

**catering** (fuar, fair, messe, party / partie service)

café break (

**café brunch** / "breakfast & lunch" (kahvaltı & öğle arası)

**canapès** / ( sıcak, soğuk snacks / appetizers / cold - kalte snacks, warme snacks, kâse - savouries / small sweets - kleine süssigkeiten / ekler.

**caramel** (burnt sugar) (karamel (zucker), karamela (şeker), caramel (sucre fondu) caramello, caramelo (azûcartostado)

**caraway** (-seed) (kümmel / kimyon / cumin / cumino / comino)

**carrots** (Karotte / havuç / carottes carote / zanahorias)



celery salt (kereviz tuzu / Sellerie salz) “Céleris / Sedani / Apio”  
 cream (şahne / rahm / krem şanti / crème fraîche / panna, cream / Nata, crema) “cream: az şekerli likör / crème(s): çok şekerli az alkollü likör”  
 cras-eis (kracked eis-crash ice-kırılmış buz)  
**chef de Rang** (waiter / kellner / garson / garçon)  
**cherry** (kirsch / kiraz / cerises / ciliege / cerezas)  
**cocktail cherry** (kokteyl kirazı/cocktailkirsche)  
**cocktail** (Hahnenschwanz / horoz kuyruğu/queue de coc)  
**cognac** (french brandy / konyak / brendi / coñjac / kognak / kanyak)  
**cold, kalte buffets** / klassische buffets, vom kalten buffet, büfe  
**croissant** (ay çöreği / hörnchen / crescent roll/cornetto/cuerno/ medialuna)  
**cinnamon** (zimt / tarçın / canelle / canella / canela)  
**coffee** (kaffee / kahve / café / caffè / kafes, kaves / kaife / kahva / cahoa)  
**clove** ( nelke - karanfil - clou de girofle - clove - chioda di garofano - elavo “de especia”)  
**closed** (geschlossen / kapalı)  
**courvert** (ç.k.b.: çatal, kaşık, bıçak / kuver / cutlery, table silver / besteck / Gedeck / posate / cubierto / cover / coperto)  
**cloak-room** (vestiyer, gardorop / garderobe/vestiaire/guardoroba/guardaroppa )  
**chocolate** (choco / czekolada / cokolata)  
 cocoa (kakao / cacao)  
**coconut** (kokosnuß, hindistan cevizi, cocos)  
**cointreau** (orange / portakal likörü)  
**kons /consommatrice** ( Gazino, bar & eğlence yerlerinde müşteri ile birlikte yiyip içerek çalıştığı yere kazanç sağlayan kadın.)  
**cost** (kişi başına çıkartılan maliyet / birim fiyatı, iyi bir yiyecek & içecek müdürü bu hesaplamayı tam yapamazsa müessese zarar eder.)  
**croissant** (Fransız ay çöreği / kek. Fransızca'da hilal demektir. Türkçe'ye kruvasan olarak geçen tereyağlı ekmek de, hilal şeklinde olduğu için adı croissant'dır.)  
**cruet-stand** (menage / ménagère, huilier / oliera / vinagreras)  
**cup** (chilled drink of wine with various flavourings) / bowle (kaltes getränk aus wein & fruchten) / bowl (şarap & meyvelerden soğuk içki) / cup (boisson froide à base de vin et fruits) / bowle (bevenda fredda di vino bianco e frutta) / bowle (bebida fría de vino blanco y fruta)  
**currant** (red) (johannisbeere / groseille (casiss) / ribes / grosella), frenk üzümü.  
**cusina / cuisine / kitchen** (mutfak, mutfak sanatı "from French cuisine, "cooking; culinary art; kitchen"; ultimately from Latin coquere, "to cook") is a characteristic style of cooking practices and traditions.")



**çay** (tee / çay / thé / tè / té / tea) Türkler'in devamlı içtikleri (Türkler şerbet, ayran, sahlep, kahveden sonra çay içmeye başlamışlardır) Türk'lerin teklif edeceği ilk şey çay'dır, çünkü türk çayı barışın sembolüdür, çayın berraklığı ,sıcaklığı se Türk'ün sıcaklığıdır ,ateş kırmızısı laleler , bayrağın kırmızısı & çayın kırmızısı Türkün kanı olup Türk'ün ta kendisidir.

**çilingir sofrası** şilengar / şölen donatan "moğol kavramı"

**dinner** (akşam yemeği)

**dry** (sec / trocken / sek / secco)

**drambuie** (whisky liquer / with honey / ballı viski likörü 40°)

drip coffee (filter kaffee / filtrelî kahve / café filtre / caffè filtro / café filtro)

**durstlöscher** (sulandırılmış / susuzluk giderici )

**double** (duble, çift / doppelt / doppio / doble )

**energy drinks** (karışımli güçlendirici içecek. " alkolle karıştırılması tehlikelidir. Tavsiye edilmez.)

**espresso** (café express) "İtalyan kahvesi"

**egg-yolk** (yolk of egg / eigelb / yumurta sarısı / rosso d'uovo, tuorlo / yema de huevo)

**eggs** (eier / yumurtalar / œufs / uova (sing. uovo) / huevos)

**entrée** (erster gang nach der Suppe - çorbadan sonra ilk giriş)

**entry** (eintritt / giriş / entrance)

**Fernet Branca** (mide / magen / stomach bitter.

40 çeşit ot & baharattan yapılır. Tadı berbattır, her barda bulundurulması olmazsa olmazdır. Barda alkolden midesi yanan kişiye tavsiye edilir. Ağrıyı anında geçirir.)

**fill up** (to fill (up) / füllen (auf) / doldurunuz (üzerine) /remplir / riempire)

**fresh** (taze / frisch / frais (f.fraîche) / fresco)

**fruit juice** (fruchtsäfte / meyve suları / jus de fruits / succhi di frutta / zumos de fruta)

**honey** (honig / bal / miel / miele)

**galliano** (vanillebasis likör, vanilya yapısı likör)

**gastronomy** (gastronomie, gastronomi / miğde bilimi) " 2 çeşit müşteri vardır 1- karın doyurmak için ! 2- damak zevki için ! "

**garnish** (garnished / garnieren, garniert / garnir, garnir / guarnire, guarnito / guarnecer, guarnecido)

**gedikli** Osmanlı'da meyhanelere verilen ad.

**grand marnier** (cognac & orange liqueur, konyak & portakal likörü)

**grapes** (trauben / üzüm / raisin noir / uva)

**half dry** (halb trocken / yarı tatlı/ demi sec / mezzo sec / medis secco)

**head-waiter** (Maitre d'hôtel / chef garçon / şef garson / ober kellner / capo-cameriere / jefe de comedor / prime camerero)

**head - cook** (küchenchef / mutfak şefi / chef de cuisine / capocuoco / jefe de cocina)



**hemdert** (barlarda veya başka ortamlarda tanımadıklarıyla hemen muhabbete giren kadınlar / muhabbetçi kadın)

**icazed** (el vermek)

**ice** (eis / buz / glace / ghiaccio / hi-elo)

**iced tea** (eistee / buzluçay / thé glacé / tè ghiacciato / té helado)

**İstanbul / Konstantiniyye mutfağı** ( asıl mesele Türk mutfağı, Yunan mutfağı, Akdeniz mutfağı vs. değildir! Osmanlı İmparatorluğu cihan imparatorluğu olduğu dönemde Konstantiniyye büyük bir metropolisti.

Türkler doğudan Asia' dan, dağlardan sel gibi geldiler. Orta Asia' nın köklü kültürünü de Anatolia' ya taşıdılar. Bu toprakların bereketini de sofralarına taşıdılar & Rumeli, Anatolia, Asia ' nın sofraya kültürünü sentezleyip Türk mutfağını oluşturdular. Konstantiniyye Osmanlı coğrafyasının sınırlarından çalışmaya gelen aşçılar kendi yöresel damak zevklerini de konstantiniyye' ye taşıdılar. ( Arnavut böreği, mantısı, ciğeri, Tatar mantısı / tabak böreği, çiğ böreği, İskender, Çağ kebabı, Ermeni midyesi, Macar gulasch, Türkish et sote / Tartarbröt / ekmeği, Fransız çorbası, Çerkez tavuğu, yoğurt, ayran, Kosovo kebab / Küfte, Saraybosna böreği, tatlısı, İnegöl köfte, Kestane şekeri, hoşmerim, otlu peynir, humuz gibi.Selçuklu mutfağında buna dahildir.

**jelly** (gelee / jelatin / gelée, aspic / gelatina)

**jigger** (measure / mař / ölçek)

**karat** / ibranice keçi boynuzu çekirdeğı ( kuyumculukta kullanılır. 5 x çekirdek = 1 gr. )

**kitchen** (küche / mutfak / cuisine / cucina / cocina)

**kuro / başsız heykel** (argodaki **kıro** burdan gelmektedir.)"

**kore** / başsız kadın heykeli

**kümmel** (kummel / cúmel) "caraway & anise seeds likör / liqueur"

**lemon squash** (pres, sıkma limon suyu / zitrone-saft (frisch gepreßt) / citron pressé / spremuta di limone / zumofresco de limón)

**lemonade** (limonade / limonata / citronnade / limonada / gazoz)

**liqueur** ( likör / liquor(e) / licor)

**lunch** (mittagessen/öğle yemeğı/déjeuner/colazione/almuerzo)

**liquid** (sıvı,likit / flüssig / liquide / liquido / líquido)

**manita / mantenuta / kapatma / metres / montinate**

**maitre d' Hotel** (restaurant chef, head-waiter, ober kellner)

**mangal** (braizer/barbecue/kohlenbecken)

**mangal kömürü** (odun kömürü/charcoal/holzkohle)

**maraschino** (liqueur from sour cherries) / maraschino (likör aus der sauer kirsche) / maraschino (liquore di marasche) / marraschino (licor de guindos) "maraschino vişnesi / kirazı, Dalmatia / Balkan"

**marc brandy, grappa** (triersterbranntwein / marc / grappa / aguardiente de



orujo)

**mulled wine / mulled claret** (glühwein / sıcak şarap / cin chaud / vino brülé, vino caldo / vino caliente)

**measure** (maß / ölçek / jigger)

**Metaxa's** ( Yunan brendisi)

**meyyal** (meyilli)

**milk-shake** (milch-shake / frullato / frappé / batido)

**mixology** / (mixologie, mixoloji / içki karışım bilimi "2 çeşit müşteri vardır: 1- boğazını ıslatmak için ! 2- damak zevki için !

**mustard** (senf / hardal / moutarde / senepe / senepa / mostarda / mostaza)

**most** (üzüm suyu ), şıra

**noel / christmas / weinachten / milad / 0 / o' günü ( Hz. İsa / Jesus / J.C. / chirstus / Yeshua ' nın doğum günü) " roşaşana : yahudilikte yılbaşı bayramı)**

**nutmeg** (muskatnuş / hint cevizi (findık büyüklüğünde) / (Noix de

**muscade** / muscat / Noce moscata / Nuez moscada)

**occupied** (meşgul / engaged / besetzt / occupé, pris / occupato / ocupado)

**open** (offen / açık / ouvert)

**oven** (Backofen / fırın / four / forno / horno)

**Ouzo** ( Yunan rakısı)

**patagones** (kızartılmış muz / muz cips / flambe muz)

**paçoz / hurpani / düşmüş kadın** ( toplumun değerlerini muhafaza etmeden yaptığı işi ucuz yapan, sallapati, paşpal)

**panè de España / pandispanya** ( İspanyol ekmeği / keki)

**panè/crumbed** (breaded, paniert, tava, impanato, panato, em panado)

**para** / şifresi içinde gizlidir, tersinden okuyunuz & paranın kimde olduğunu görünüz ! "Arap"

**parola cıss ! / dikkat ! hadidülmizac** / öfkeli müşteri geliyor !

**parsley** (petersilien / maydanoz / persillées / prezzemolo / perejil)

**pâtisserie/pasticceria/pastane** (is the type of French or Belgian bakery that specializes in pastries & sweets. In both countries it is a legally controlled title that may only be used by bakeries that employ a licensed maître pâtissier (master pastry chef).)

**peach** (pfirsich / şeftali / pêches / pesche / melocotón)

**pearl onion** (perlzwiebel, inci soğan) "kokteyl soğanı"

**peat** (torf / kurutulmuş turba yakıtı) "turba: az çok kömürleşmiş bitkilerden oluşan yakıt (tourbe)" "İskoç viski damıtımlarında kullanılır."

**peel** (schale / kabuk / pelure / buccia / cáscara)

**pedofili / sübyancı**

**peppermint sprigs** (nane yaprakları / pfefferminze / menthe (poivrée / menta, hierbabuena)

**pickles** (tek veya 2 çatalı **canapès, cocktails** çubukları



**pipette** ( Strohthalm - straw-pipette-chalumeau-trinkhalm, halk dilinde / argo "kamış" )

**plum** (pflaumen / erik / prunes / prugne / ciruelas)

**port** (portwein / akdeniz ülkeleri liman şarabı / porto / oporto)

**podium** (yüksek bir basamakla giriş, basamaklara çıkıldıktan sonra, yüksek bir alan, roma tapınakları mutlaka podyum üzerinde yapılmaktaydı, etrux & greek karışımı roma mimarisidir & semerdan çatılı priz & alınlıklıdır.)

**punch** (punsch / pañç / ponce / ponche)

pumpkin (squash / gourd / kürbis / kabak / potiron / courge / zucca / calabaza)

**raggione / rajon** (yol, yöntem, usul.gösteriş, fiyaka)

**salam / salamis / zamanın en eski menu'sü** (Alasia / Kıbrıs / Cyprus / ' ta döneminde yapılmış menu, et parçaları, kuru yemişlerin domuz derisine, bağırsağına doldurulup kurutulmuş olan şimdiki salam.)

**recipe** (recette/rezpete/reçete)

**réchaud** (ısıtıcı / chauffe-plat / chalfing-disch / hotplate / scal dapiatti / calentador/ "reşo" )

**red (black) currant** (frenk üzümü / johannisbeer / groseilles / ribes / grosellas)

**restaurant** (lokanta / lokal / local / gasthaus, / ristorante / trattoria / fonda)

**refreshing** (erfrishend / tazeleyici / ferahlatıcı)

**remmal/falcı/medium / kam** ( fal açıp gelecekte haber veren - remil çekmek, fal bakmak, remil atmak)

**safran / asfar / za'feran / safranum / saffrom/ zafferano / azafran** ( Araçça sarı renk)

**satanus** (şeytanın latincesi)

**self-service** (self servis / cafeteria / help yourself / selbe Bedienung (bedienen sie sich) / servez - vous / sia serva / sirvase / self servis / auto servicio / libre - service)

**serender** (erzak kulübesi / Karadeniz yöresine özgüdür. Altı boş, yerden yüksektir.)

**servatius** ( servis yapan, garson, roma döneminde esir hizmetli)

**siesta** ( sıcak yaz ayları, akdeniz ülkeleri alışkanlığı olan " siesta" saat 12:00 / 14:00 arası iş paydosu. Türkiye ' de bir Akdeniz ülkesi değil mi ? bu alışkanlık bizde de uygulansa olmaz mıydı ? )

**syrup** ( sirup / şurup / sirop / sciroppo / jarabe)

**squash** (sıkma / gepreßt / spremuta / zumo fresco / pres / pressé / saft)

**sugared** (gezuckert / şekerlenmiş / sucré, zuccherato / azucarado)

**sugar-candy** (rock candy / kandis zucker / kandis şeker / sucre candi / zuccherero candito / azúcar cande , candi)

**snack** (snackbar / imbiß / collation / casse - croûte / spuntino / colación / refrigerio / büfe)

**susuzluk giderici** (durstlöscher)

**strainer** (seiher / bar süzgeci / passoire / colino / colador)





**straw** (trinkhalm / strohhalm / pipette, pipet / chalumeau / paille)  
**strawberry** (erdbeer / çilek / fraises / fragole / fresas)  
**sweden punch** (schweden punsch-rumbasis likör, rum yapısı likör)  
**sweet** (entremets-süße speisen-pattis-sweet dish-dessert-postres-süßspeise-  
tatlı-doce-dulce-pâtisserie-nachtisch)  
**sweet cider** (apfelsaft "süßmost" / elma suyu / cidre doux / sweet cider /  
succo di mele / jugo de manzanas)

**sofra** (sefer, yolculuk, yiyecek torbası.)



**spa** ("selus per aquam" anlamındadır.) Spa manada sağlık, zindelik, estetik & güzelliğin, suyun iyileştirici gücüyle geri kazanmaktır. Geçmiş Roma İmparatorluğuna kadar uzanır.

**sparkling wine** (schaumwein / sekt / köpüklü şarap / şampanya / vin mousseux / (spumante / vino espumoso)

**şarap meftunu** (alkolik/alcoholic /narkoz almış)

**tabl d'hôte** / set menu / self service

**tinned** (kutu konserve / am. canned / dosen / en boîte / in scatola / en conserva)

**tranche** (slice / scheibe / schnitte / fetta, trancia / tranciol lonja/ tajada/ kesme)

**tobacco shop** / kapalı sigara ve içki satılan yer

**Turkenblut / Türkkanı / Turkishblood**

( red wine & champagne " Türklere karşı savaşı kazanan şovalyeler zafer kutlaması için yaptıkları kokteyl)

**triclinium** (Eski Roma döneminde yemek odası.)

**vermouth** (wermut / pelin otu / vermuth / vermut / Wormwood / absinthe)

**vinaigre** (vinegar / essig / sirke / aceto / vinagre / absinthe / womewood)

**wacholderbeere** (juniper-berry / İngiliz berrak kuş üzümü / beaie de genièvre)

**wheat** (Weizen / buğday / froment)

**wine-waiter** (wine-butler / weinkellner / şarap garsonu / sommelier)

**wine - bucket** (weinkühler / şarap soğutucusu, kovası / seuu à champagne / secchiello da champagne / cubo del champãna)

**wine** (wein / şarap / vin / vino)

**white of egg** (eiweiß / yumurta akı / blanc d'œuf / chiara d'uovo, albume / clara de huevo)

**waiter** (kellner / garson / garçon /chef de Rang / cameriere / camarero)

**waitress** (kellnerin, Fräulein / bayan garson/ chef de Rang / serveuse / cameriera / camarera / señorita / dam/ dame / madamme)

**yogurt** (yoghurt / yaourt / joghurt / yogourt / iogurt / yogur).

**V.I.P.** (very important person, çok önemli kişi)

**Vitamin** Latince "vita" / yaşam demektir. Sağlıklı yaşamın vazgeçilemez organik bileşenidir. 01- Yağda eriyen vitaminler: A, D, E,K.

02- Suda eriyen vitaminler: B,C.

**ithal / import** ( dışarıdan getirilen ürün)

**ihraç / export** ( dışarıya gönderilen ürün)





**SHAKER (sh. /mixtarius / mixology / mixologie / mixoloji / coctelera / Schüttelbecher / çalkalayıcı / çalkalama kabı)**

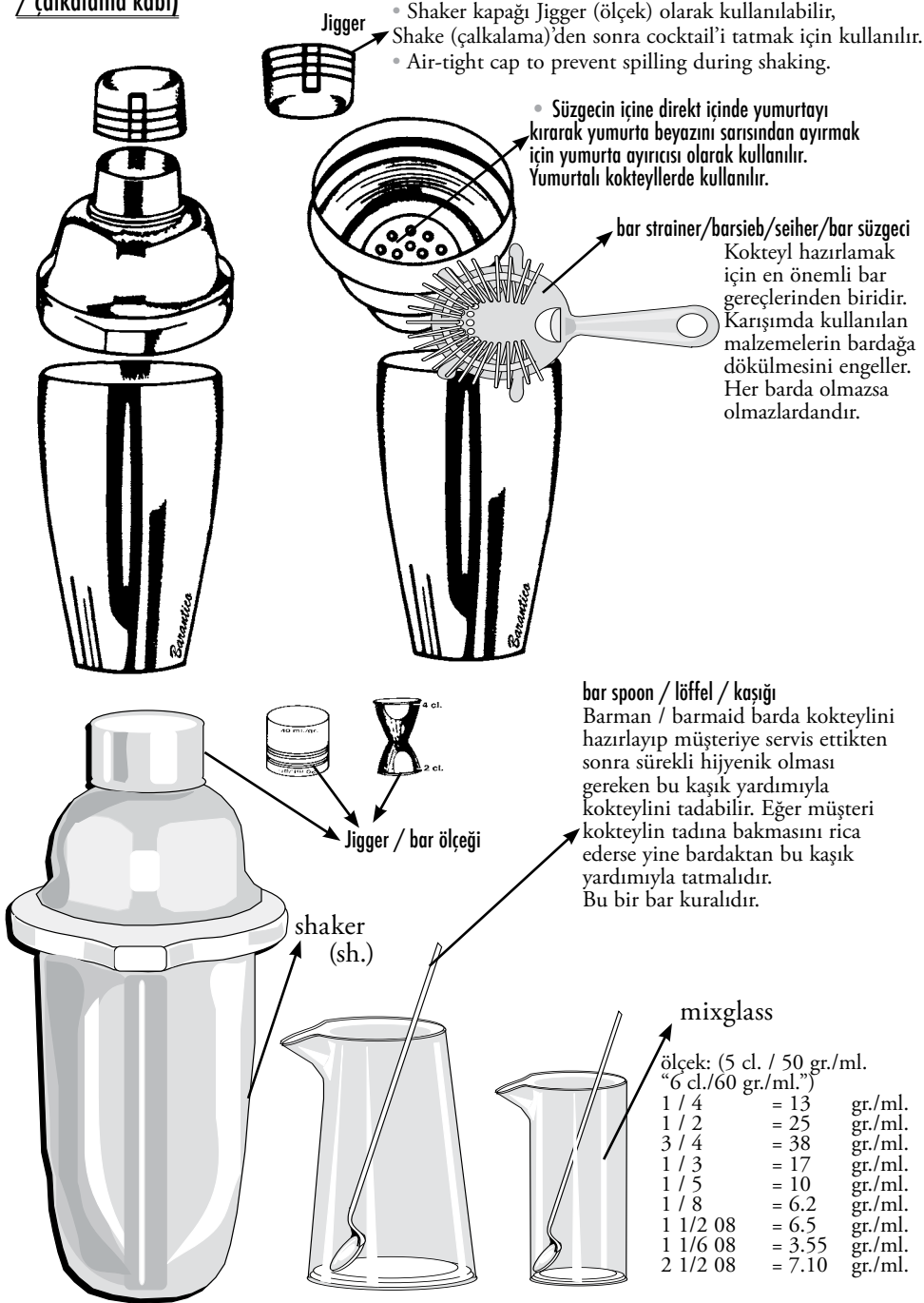

## The standard spirit measures

1/4 gill (known as a half (1/2) one) = 1 1/4 fluid ounces or 3.55 centi-litres / cl.  
 1/2 gill (known as a glass or large one) = 2 1/2 fluid ounces or 7.10 centi-litres / cl.  
 1 pint = 20 fluid ounces = 56.82 centi-litres / cl.

## BAR ÖLÇEKLERİ / BAR MEASURES / BAR MAßE

1 quart .....	~ 94.63 cl./950 gr. 32 ounces -oz
1/5 .....	~ 75.70 cl./800 gr. 25.6 ounces
1 pint.....	~ 47.31 cl./470 gr.16 ounces
1 pony.....	~ 2.95 cl./300 gr.1 ounce
1 jigger/maß/measure/ölçek .....	~ 4.43 cl./45 gr.1 1/2 ounces
1 wine glass / wein glas .....	~ 11.82 cl./120 gr. 4 ounces
1 teaspoon / barspoon / long stiel loffel .....	~ 0.36 cl. 1/8 ounce
1 dash / spritzer/schub / fıskırtı .....	~ 1/8 tea / barspoon / barsp.

**pré dinner drinks** : “aperitifs - short drinks” 7 cl.“70 g./ml.” (sugar syrup or liqueur together max. 2 cl.)

**after dinner drinks**: “digestifs / desserts” max 7 cl./70 g./ml.

**long drinks** : min. 14 cl. - max. 28 cl. (max. alcohol 8 cl.)

(These mixtures include max. 5 materials.)

1 measure = 2/5 gill = 2oz. = (5 cl.) - = 6 cl. = (50 g.) - 60 g./ml.

1 pound = 453 g./ml. 1gallon = 4,54 Liter

1 ounce (U.S.) = 480 minims = 8 drams = 0.25 gills = 0.0625 pints = 0.0312 quarts = 0.0078

gallons = 1.80468 m<sup>3</sup> = 2.95737 cl. (~ 3 cl./ 3 cl. = 30 g.) / (1 ounce = 28.35 g./ml. ~ 3 cl.)

1 ounce/oz. = ~ 3 cl. = 30 g./ml. 1 cl.= 10 g./ml.

dash/spritzer/fıskırtı= \_\_\_\_\_ 1/8 bar/tea spoon/sp.  
 60 drops/damla/tropfen= \_\_\_\_\_ 1 bar/teasp.  
 3 teaspoons (1-2 ounce)= \_\_\_\_\_ 1 tablespoon  
 1 cup (8 ounces)= \_\_\_\_\_ 16 tablespoons  
 2 cups (16 ounces)= \_\_\_\_\_ 1 pint  
 4 cups (32 ounces)= \_\_\_\_\_ 1 quart  
 4 quarts= \_\_\_\_\_ 1 gallon / 4.546 lt.



Boston Shaker



## kısaltmalar / abkürzungen, zeichenerklärung / abbreviation

sh.	= shaker/schüttelbecher/çalkalayıcı/çalkalama kabı
mg.	= mixglass / Rührglas
mix.	= mixer / mixgerät
cl.	= ccl. / centiliter / santilitre
g./gr.	= gr. / gram
cap.	= capacity / kapasität / kapasite
barsp.	= barspoon (teaspoon) / bar löffel / bar kaşığı (long stiel loffel)
sp.	= spoon / löffel / kaşık
spc.	= special
tbsp.	= tablespoon / yemek kaşığı
Sp.c.	= special, spesiyal, özel.
gal.	= gallon
c.	= cup
oz.	= ounce
pt.	= pint
qt.	= quart
ml.	= mililiters
imp.	=imperial
L.	= lt. / liter / litre/ltr.
d.	= dash / fişkirtı



sifon / syphon

- \* 2-5 years old / jahre / alt / yıllık / yaşında
- \*\* 3-8 years old / jahre / alt / yıllık / yaşında
- \*\*\* 5-10 years old / jahre / alt / yıllık / yaşında

**V.O.** (very old) 10-15 years old / jahre / alt / yıllık / yaşında  
**V.O.P.** (very old product) 15 years old / jahre / alt / yıllık / yaşında  
**V.S.O.P.** (very superior old product) 20 years old / jahre / alt / yıllık / yaşında

**V.V.S.O.P.** (very very superior old product) 25 year old / jahre / alt / yıllık / yaşında  
**X. O.** (extra old) 30 years old./30 jahre alt / 30 yıllık / yaşında  
**Extra** (extra) **50 years old.** / 50 jahre alt / 50 yıllık / yaşında

**L.P.** (London Particular) Londra'ya özel  
**C.O.M.** (Choice Old Marsala) seçkin eski marsala  
**O.P.** (Old Particular) eskiye özel  
**S.O.M.** (Superior Old Marsala) en üstün & eski marsala

\* Gıda Boyalı / \* dye-stuff / \* Mit Farbstoff

\*\* Gıda Boyasız / \*\* Ohne Farbstoff





stingy barman / knauseriger barman / pinti barmen



bira  
köpük alma kaşığı /  
bierschaumlöffel



bira  
köpüktürücüsü  
(stirr)



sifon / syphon

















classic / antique  
bira şişesi / bottle



bira ısıtıcısı /  
bierwärmer







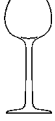

## capacities of glasses / glas kapasitat / bardak kapasiteleri

Cocktail		~ 7.39 cl./-75 g.2	1/2 ounce/oz.
Whisky		~ 7.39 cl./-75 g. 2	1/2 ounce/oz.
Old fashioned		~ 17.74 cl./-175 g.	6 ounces/oz.
Sherry		~ 7.39 cl./-75 g. 2	1/2 ounces/oz.
Champagne		~ 14.78 cl./-150 g.	5 ounces/oz.
Delmonico		~ 20.70 cl./-210 g.	7 ounces/oz.
Highball		~ 29.57 cl./-250 g.	10 ounces/oz.
Tom Collins		~ 35.48 cl./-350 g.	12 ounces/oz.
Goblet		~ 29.57 cl./-295 g.	10 ounces/oz.
Tumbler		~ 29.57 cl./-300 g.	10 ounces/oz.
Sauterne		~ 11.82 cl./-120 g.	4 ounces/oz.
Claret		~ 11.82 cl./-120 g.	4 ounces/oz.
Cordial		~ 2.95 cl./-30 g.	1 ounce/oz.
Shot/pony		~ 2.95 cl./-30 g.	1 ounce/oz.
Çay/Tea/Tee		~ 8.5 cl./-85 g./-3	ounces/oz.

## bardak terminolojisi / glas terminologie / glass terminology - FORM

### sarap / wein / wine

<p>Art.Nr. 01- (81) rhine long stemmed</p>  <p>ø :..... cm. h. :..... cm. cap.:.....cl./.....gr./ml. (capacity / kapasite/ kapasitat)</p>	<p>02-(53) beyaz / white/ wei</p>  <p>ø :..... cm. h. :..... cm. cap.:.....cl./.....gr.</p>	<p>03-(55) kırmızı / red rot burgunder</p>  <p>ø :..... cm. h. :..... cm. cap.:.....cl./.....gr.</p>	<p>04-(1) kırmızı / red rot burgunder</p>  <p>ø :..... cm. h. :..... cm. cap.:.....cl./.....gr.</p>
<p>05-(4) kırmızı / red rot burgunder</p>  <p>ø :..... cm. h. :..... cm. cap.:.....cl./.....gr.</p>	<p>06-(63) romer</p>  <p>ø :..... cm. h. :..... cm. cap.:.....cl./.....gr.</p>	<p>07-(1) beyaz / white/ wei</p>  <p>ø :..... cm. h. :..... cm. cap.:.....cl./.....gr.</p>	<p>08-(18) kırmızı / red rot burgunder</p>  <p>ø :..... cm. h. :..... cm. cap.:.....cl./.....gr.</p>



09-(19)  
beyaz /  
white/  
weiß



ø :..... cm.  
h. :..... cm.  
cap.:.....cl./.....gr./ml.  
(capacity / kapasite/  
kapasitat)

10-(94)



ø :..... cm.  
h. :..... cm.  
cap.:.....cl./.....gr.

11-(88)



ø :..... cm.  
h. :..... cm.  
cap.:.....cl./.....gr.

12-(78)  
Goblet "paris"  
kelch, cup,  
kupa  
general  
purpose glass  
most wines



ø :..... cm.  
h. :..... cm.  
cap.:...6...cl./.....gr.  
(ounce)

13-(72)  
Port glass  
"goblet"



ø :..... cm.  
h. :..... cm.  
cap.:.....cl./.....gr./ml.

14-(73)  
sherry



ø :..... cm.  
h. :..... cm.  
cap.:.....cl./.....gr.

15-(21)  
sherry



ø :..... cm.  
h. :..... cm.  
cap.:...9...cl./900. gr.

16-(25)  
sherry



ø :..... cm.  
h. :..... cm.  
cap.:.....cl./.....gr.

17-(95)  
sherry



ø :..... cm.  
h. :..... cm.  
cap.:.....cl./.....gr./ml.

18-(44)



ø :..... cm.  
h. :..... cm.  
cap.:.....cl./.....gr.

19-(67)  
sherry



ø :..... cm.  
h. :..... cm.  
cap.:.....cl./.....gr.

20-(66)  
sherry



ø :..... cm.  
h. :..... cm.  
cap.:.....cl./.....gr.

20-A  
kırmızı /  
red  
rot  
Bordeaux



ø :..... cm.  
h. :..... cm.  
cap.:.....cl./.....gr./ml.

20-b  
Vauvray



ø :..... cm.  
h. :..... cm.  
cap.:.....cl./.....gr.

20-c  
Anjou

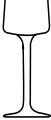

ø :..... cm.  
h. :..... cm.  
cap.:.....cl./.....gr.

20-d  
Alsace



ø :..... cm.  
h. :..... cm.  
cap.:.....cl./.....gr.

20-e  
beyaz /  
white/  
weiß  
Bordeaux



ø :..... cm.  
h. :..... cm.  
cap.:.....cl./.....gr./ml.

20-f  
beyaz /  
white/  
weiß  
Burgunder



ø :..... cm.  
h. :..... cm.  
cap.:.....cl./.....gr.

\* İlk şarap bardağı **Anatolien**' de bulunmuştur.  
\* Das erste weinglas wurde in **Anatolien** gefunden.  
\* **Anatolia**; güneşin yolu (Sunway - sonenweg) demektir.  
Asos'sda tanrıçanın (Anatolia) ellerinin arasından doğan güneşin adı.  
Rumcada doğu anlamındadır.



## sampanya / champagne / champain / sekt / sparkling wine

21-(7)  
sektsschale



ø :..... cm.  
h. :..... cm.  
cap.:.....cl./.....gr./ml.  
(capacity / kapasite/  
kapasitat)

22-(71)  
champagne  
"Tulip-  
shaped"



ø :..... cm.  
h. :..... cm.  
cap.:.....cl./.....gr.

23-(59)  
sektflöte



ø : 5.3 cm.  
h. : 20.5 cm.  
cap.: 12 cl./120 gr./  
ml.

24-(43)  
champagne  
"Tulip-  
shaped"



ø :..... cm.  
h. :..... cm.  
cap.:.....cl./.....gr.  
(ounce)

25-(58)  
sektspitz



ø :..... cm.  
h. :..... cm.  
cap.:.....cl./.....gr./ml.

26-(3)  
sekt



ø :..... cm.  
h. :..... cm.  
cap.:.....cl./.....gr.

27-(49)  
sektkelch  
kelch, cup,  
kupa



ø :5.5 cm.  
h. :18.5 cm.  
cap.: 0.1 l.

28-(50)  
sektkelch  
kelch, cup,  
kupa



ø :..... cm.  
h. :..... cm.  
cap.:.....cl./.....gr.

29-(40)  
sektsschale  
champagner  
kelch



ø :..... cm.  
h. :..... cm.  
cap.:.....cl./.....gr./ml.

30-(68)  
sekt



ø :..... cm.  
h. :..... cm.  
cap.:.....cl./.....gr.

31-(22)  
champagne  
flöte



ø :..... cm.  
h. :..... cm.  
cap.:.....cl./.....gr.

32-(41)  
sekt



ø :..... cm.  
h. :..... cm.  
cap.:.....cl./.....gr.

33-(93)  
sektspitz



ø : 6 cm.  
h. : 21 cm.  
cap.: 0.11 l.

34-(92)  
sekt



ø :..... cm.  
h. :..... cm.  
cap.:.....cl./.....gr.

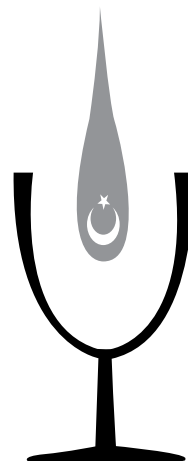

## bira / bier / beer

35  
mug/krug  
kupa



ø : 8.5 cm.  
h. : 15.5 cm.  
cap.: 0.5 l.

36-(12)  
mug/krug  
kupa



ø : 9 cm.  
h. : 15 cm.  
cap.: 0.6 l.

37-(62)  
mug/krug  
kupa



ø : ..... cm.  
h. : ..... cm.  
cap.: .....cl./.....gr./ml.

38  
pils



ø : 7 cm.  
h. : 17 cm.  
cap.: 0.4 l.

39-(6)



ø : 8.5 cm.  
h. : 15.5 cm.  
cap.: 0.5 l.

40-(13)  
beer  
pilsener



ø : 6 cm.  
h. : 20.5 cm.  
cap.: 0.2 l.

41-(80)  
**tumbler**  
ayaksız /  
sapsız silindirik  
bardak, kısa  
tumbler, uzun  
tumbler bardak  
diye sınıflandırılır



ø : 6.5 cm.  
h. : 15 cm.  
cap.: 0.33 l.

42-(60)  
used for  
lager



ø : 6 cm.  
h. : 18 cm.  
cap.: 0.30 l.

43-(79)  
worthington



ø : 5 cm.  
h. : 18 cm.  
cap.: 0.2 l.

44-(83)  
pilsner



ø : 5 cm.  
h. : 18 cm.  
cap.: 0.2 l.

45-(87)  
tumbler



ø : ..... cm.  
h. : ..... cm.  
cap.: .....cl./.....gr./  
ml.

## cocktail / kokteyl

46-(30)  
cocktail /  
martini



ø : ..... cm.  
h. : ..... cm.  
cap.: .....cl./.....gr./ml.  
(capacity / kapasite)

47-(31)  
cocktail  
martini



ø : ..... cm.  
h. : ..... cm.  
cap.: .....cl./.....gr.

48-(32)  
cocktail /  
martini



ø : ..... cm.  
h. : ..... cm.  
cap.: .....cl./.....gr./ml.

49-(33)  
cocktail /  
martini



ø : ..... cm.  
h. : ..... cm.  
cap.: .....cl./.....gr.

**mise en place / ön hazırlık:** martini hazırlarken sticke batırılmış zeytinler limon suyu dolu bir bardağın içine konulmalıdır. Bu işlem yapılmazsa zeytin yağı martini üzerinde yüzer, damak zevkini bozar. Akademik olmaz.





51  
cocktail /  
martini



ø : ..... cm.  
h. : ..... cm.  
cap.: .....cl./.....gr.

52-(82)  
cocktail/  
frappé/  
dry  
martinis



ø : ..... cm.  
h. : ..... cm.  
cap.: .....cl./.....gr.

53-(100)  
cocktail



ø : ..... cm.  
h. : ..... cm.  
cap.: .....cl./.....gr./ml.

54-(28)  
cocktail  
long drinks



ø : 7 cm.  
h. : 17 cm.  
cap.: 0.4 l.

55-(24)  
cocktail



ø : ..... cm.  
h. : 11.5 cm.  
cap.: 13.5cl./135gr.

52-(82)  
cocktail/  
frappé/  
dry  
martinis



ø : ..... cm.  
h. : ..... cm.  
cap.: .....cl./.....gr.

56-(42)  
cocktail  
shale  
martini

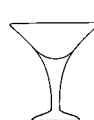

ø : ..... cm.  
h. : ..... cm.  
cap.: .....cl./.....gr./ml.

57-(29)  
long drinks  
collins



ø : ..... cm.  
h. : ..... cm.  
cap.: .....cl./.....gr./  
ml.

58-(9)  
collins



ø : ..... cm.  
h. : ..... cm.  
cap.: .....cl./.....gr.

59-(75)  
fizz/  
fişirtılar



ø : ..... cm.  
h. : ..... cm.  
cap.: .....cl./.....gr.

60-(75 A)  
long drink  
& sometimes/  
mançmal/  
bazen  
as a/als/olarak  
highball glass



ø : ..... cm.  
h. : ..... cm.  
cap.: .....cl./.....gr./ml.

61-(39)  
long drink



ø : 6.3 cm.  
h. : 15 cm.  
cap.: 28 cl./280 gr./  
ml

62-(27)  
whiskey  
sour



ø : ..... cm.  
h. : ..... cm.  
cap.: .....cl./.....gr.

63-(70)  
sour



ø : ..... cm.  
h. : ..... cm.  
cap.: .....cl./.....gr.

64-(61)  
sour



ø : ..... cm.  
h. : ..... cm.  
cap.: .....cl./.....gr./ml.

65-( )  
sour



ø : ..... cm.  
h. : ..... cm.  
cap.: .....cl./.....gr./  
ml.

66-(77)  
old  
fashioned



ø : ..... cm.  
h. : ..... cm.  
cap.: .....cl./.....gr.

67-(77-A)  
tumbler / whisky  
old fashioned  
on the rocks  
on ice / auf eis  
buz üstü



ø : ..... cm.  
h. : ..... cm.  
cap.: .....cl./.....gr.

68-(37)  
on the rocks  
on ice / auf eis  
buz üstü



ø : 7.6 cm.  
h. : 9 cm.  
cap.: 22 cl./220 gr./ml.

69-(52)

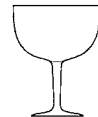

ø : 11 cm.  
h. : 15.3 cm.  
cap.: 16 cl./160gr./  
ml.



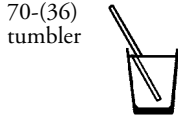

70-(36)  
tumbler

ø : ..... cm.  
h. : ..... cm.  
cap.: .....cl./.....gr.

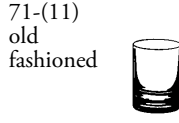

71-(11)  
old  
fashioned

ø : 7.2 cm.  
h. : 8.5 cm.  
cap.: 16 cl./170 gr./  
ml.

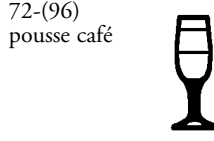

72-(96)  
pousse café

ø : ..... cm.  
h. : ..... cm.  
cap.: .....cl./.....gr./ml.

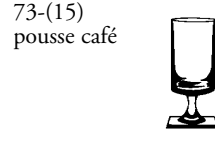

73-(15)  
pousse café

ø : 7 cm.  
h. : 17 cm.  
cap.: 0.4 l.

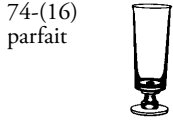

74-(16)  
parfait

ø : ..... cm.  
h. : ..... cm.  
cap.: .....cl./.....gr.

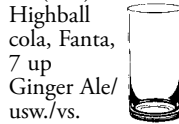

75-(101)  
Highball  
cola, Fanta,  
7 up  
Ginger Ale/  
usw./vs.

ø : 7.2 cm.  
h. : 8.5 cm.  
cap.: 16 cl./170 gr./  
ml.

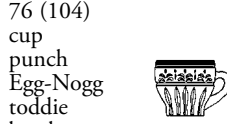

76 (104)  
cup  
punch  
Egg-Nogg  
toddie  
bowle

ø : 8 cm.  
h. : 7.4 cm.  
cap.: 12 cl./120 gr./ml.

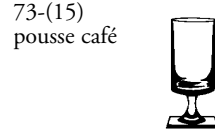

73-(15)  
pousse café

ø : 7 cm.  
h. : 17 cm.  
cap.: 0.4 l.

## Rakı (lion's milk - löwen milch - aslan sütü ) / ouzo

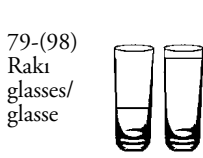

79-(98)  
Rakı  
glasses/  
glasse

ø : 5.6 cm.  
h. : 12 cm.  
cap.: 16 cl./160 gr./  
ml.

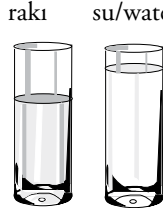

rakı su/water/wasser

80-(10)  
whiskey,  
whisky  
shot/ponny  
schnaps

ø : ..... cm.  
h. : ..... cm.  
cap.: 2-4 cl./20-40 gr.

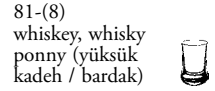

81-(8)  
whiskey, whisky  
ponny (yüksük  
kadeh / bardak)

ø : 7 cm.  
h. : 17 cm.  
cap.: 0.4 l.

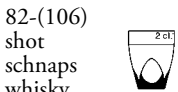

82-(106)  
shot  
schnaps  
whisky  
whiskey

ø : 4.7 cm.  
h. : 5.5 cm.  
cap.: 2 cl./20 gr./ml.

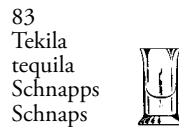

83  
Tekila  
tequila  
Schnapps  
Schnaps  
Korn  
Rakı  
Ouzo  
Fernet Branca

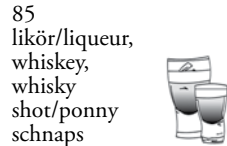

85  
likör/liqueur,  
whiskey,  
whisky  
shot/ponny  
schnaps  
Fernet Branca  
(mide /  
magen /  
stomach  
bitter.)

### Dans eden Rakı:

Bu işlem için 2 adet standart rakı bardağı yan yana konur. Birine önceden soğutulmuş (gerekirse içinde buz eritilerek soğutulmuş) su konur. Bir diğerine 5 cl. / 50 gr. rakı konur. İki bardak eğik konumda ucuca öpüştürülür. Rakı dolu bardak, su dolu bardağa eğik konumu çok yavaş artırılarak aralıksız boşaltılır. Su dolu bardak dik konuma geldiğinde rakıyla su arasında ince bir çizgi oluşur. Rakı suyun havayla etkileşimini engeller. Bu sayede iki farklı molekül birbirine karışmaz. Bardağı oynattıkça rakı ile su arasındaki ince çizgi dans eder. **Haydi hayırlı keyifler.** "Hey barman bana da bir dans eden rakı lütfen!"



85-(77-A)  
**tumbler**  
whisky  
pure/pur  
on the rocks  
on ice / auf  
eis  
buz üstü.



ø :..... cm.  
h. :..... cm.  
cap.:2-4 cl./20-40.  
gr./ml.

86-(38)  
**tumbler**  
whisky  
pure/pur  
on the rocks  
on ice / auf eis  
buz üstü



ø :..... cm.  
h. :..... cm.  
cap.:2-4 cl./20-  
40.gr./ml.

87-(11)  
**tumbler**  
whisky  
pure/pur  
on the rocks  
on ice / auf eis  
buz üstü



ø :..... cm.  
h. :..... cm.  
cap.:2-4 cl./20-40.  
gr./ml.

88-(23)  
cognac  
brandy  
liqueur



ø : 5.7 cm.  
h. : 10.5 cm.  
cap.: 20 cl./200 gr./  
ml.

## Cognac / brandy / liqueur

89-(69)  
cognac  
brandy  
liqueur



ø :..... cm.  
h. :..... cm.  
cap.:.....cl./.....gr.

90  
brandy  
liqueur  
cognacschwenker



ø :..... cm.  
h. :..... cm.  
cap.:2-4 cl./20-  
40.gr./ml.

91-(76)  
**balloon**  
cognac  
brandy  
liqueur



ø :..... cm.  
h. :..... cm.  
cap.:2-4 cl./20-40.  
gr./ml.

92-(89)  
cognac  
brandy  
liqueur



ø :..... cm.  
h. :10.6 cm.  
cap.:27cl./270 gr.

**Şayet cognac, brandy, liqueur kahve yanında sunulursa 2 cl. / 20 gr. konulur!**

93-(90)  
cognac  
brandy  
liqueur



ø :..... cm.  
h. :..... cm.  
cap.:.....cl./.....gr.

94-(91)  
cognac  
brandy  
liqueur



ø :..... cm.  
h. :..... cm.  
cap.:2-4 cl./20-  
40.gr./ml.

95-(25)  
(likör-liqueur)  
cordial



ø : 4.3 cm.  
h. : 11.7 cm.  
cap.: 4 cl./ 40 gr./ml

96-(84)  
liqueur



ø :..... cm.  
h. :..... cm.  
cap.:.....cl./.....gr.

## liqueur / likör

97-(85)  
liqueur



ø :..... cm.  
h. :..... cm.  
cap.:.....cl./.....gr.

98-(86)  
liqueur



ø :..... cm.  
h. :..... cm.  
cap.:.....cl./.....gr.

99-(95)  
(likör-liqueur)  
cordial



ø :..... cm.  
h. :8.7 cm.  
cap.:3cl./30 gr.

100-(74)  
liqueur



ø :..... cm.  
h. :..... cm.  
cap.:.....cl./.....gr.



## su / water / beverages

101-(102)  
su/water/  
wasser



ø : ..... cm.  
h. :10 cm.  
cap.:21cl./210 gr.

102-(103)  
su/water



ø : ..... cm.  
h. : ..... cm.  
cap.:2-4 cl./20-40.gr./ml.

103-(87)  
**tumbler**  
soft drinks  
su/water



ø : ..... cm.  
h. : ..... cm.  
cap.: .....cl./ .....gr.

## çay / tea / tee

106-(97)  
çay/tea



ø : 5 cm.  
h. : 8 cm.  
cap.:8.5 cl./85 gr./ml.

107-(97)  
çay/tea



ø : 5 cm.  
h. :8.3 cm.  
cap.:8.5 cl./85 gr./ml.

109  
kahve, çiss...!

ø : ..... cm.  
h. : ..... cm.  
cap.: ..... cl./ ..... gr./ml.



## Irish coffee / İrlanda kahvesi / Eire coffee

110-( )  
Irish coffee

ø :6.5 cm.  
h. :14.5 cm.  
cap.:18 cl. cl./ 180 gr./ml.



kahve : (coffee / kaffee / café / kafes / caffè / gayves / kahwa / gayfes / kaves) kelimesi dünyaya Türkler'den (Ottoman / Othomanikos / Osmanlı) yayılmıştır.

cezve / cezves : (for making Turkish coffee, kahve / kleines Stielgefäß zur zu  
Bereitung von türkischer kaffee, kahve, kaife)

## Turkish coffee / Türkisher kaffée - mocca

Art.Nr.  
113-(106)  
fincan  
cup / tasse  
flincani.



ø : 6 cm.  
h. : 6 cm.  
cap.: 6 cl./ 60 gr./ml.

114-(105 )  
cezve/ cezves  
(for, für 3  
persons,  
personen.)

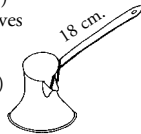

ø : 5 cm.  
h. :8.3 cm.  
cap.:8.5 cl./85 gr./ml.

fincan : (tasse / cup / flincani)

mangal : (braizer/barbecue/kohlen-becken)

mangal kömürü : (odun kömürü/ charcoal/holzkohle)

kahve köpüğü (kafes kaymaki / coffee cream / kaffee schaum).



# BAR PLAN 01

ölçek: 1/20

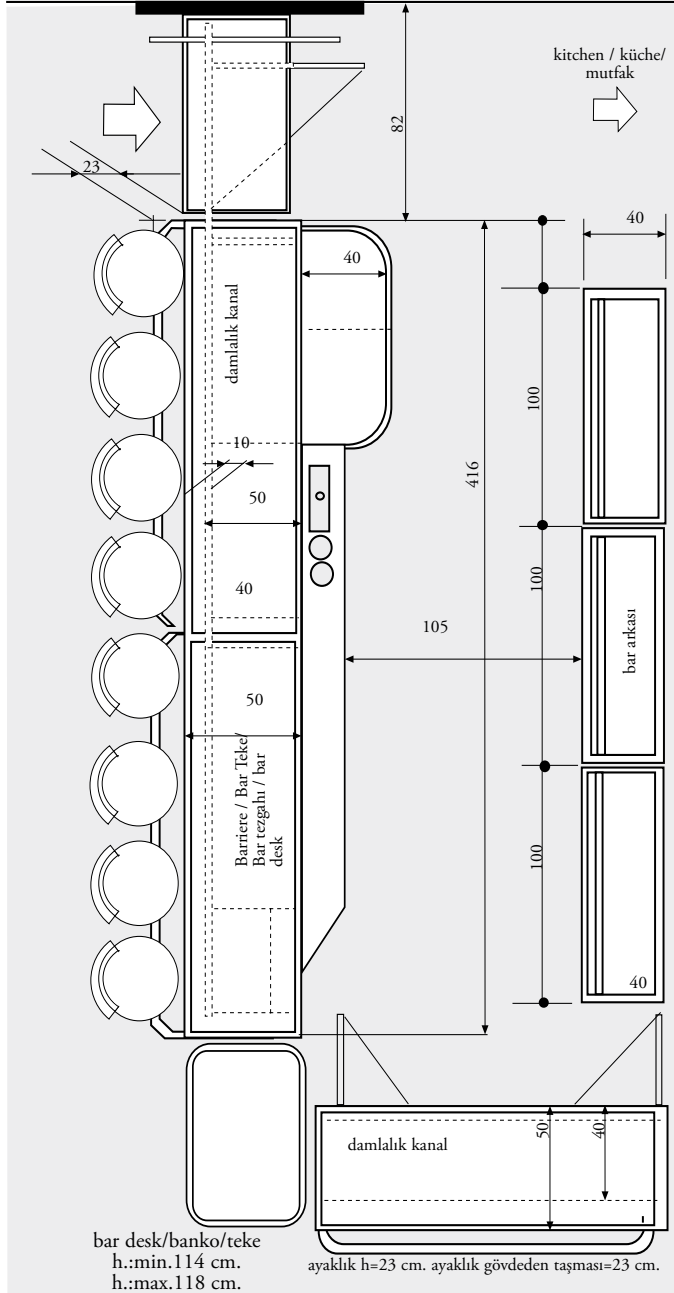

Erhan Mert  
mimar / architect / architek



# BAR PLAN 02

## ölçeksiz

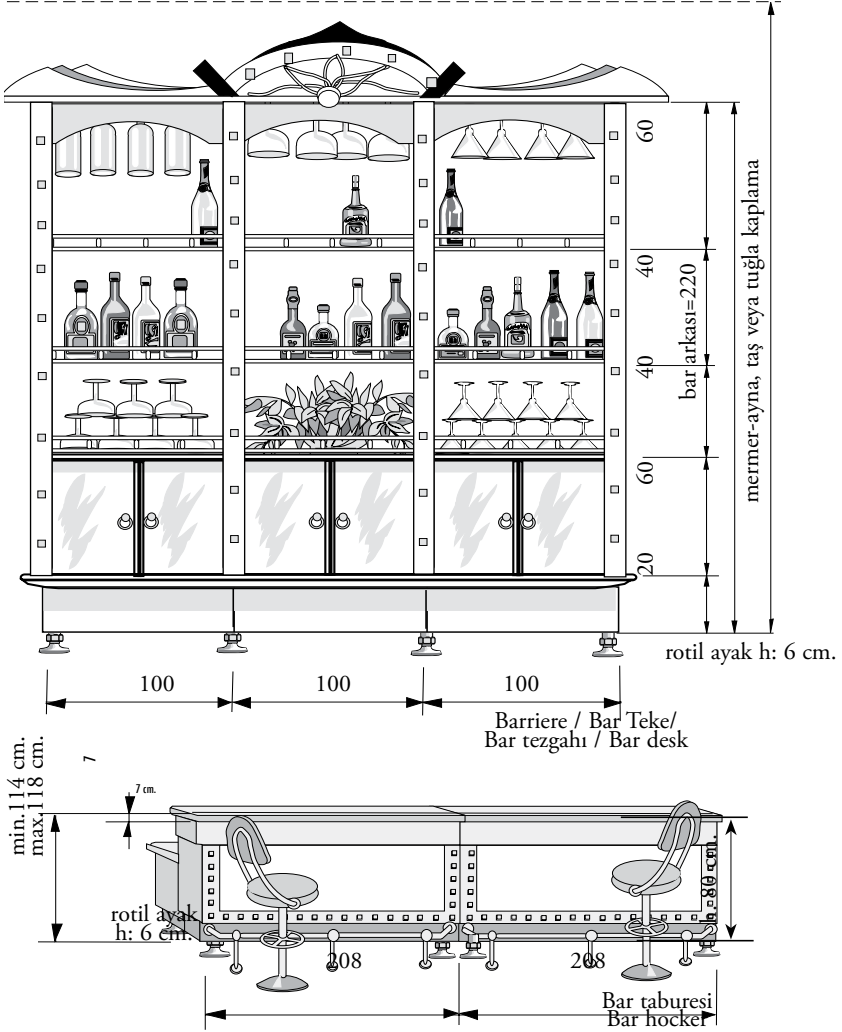

Erhan Mert  
mimar / architect / arhitekt



# BAR PLAN 03

## ölçek: 1/50

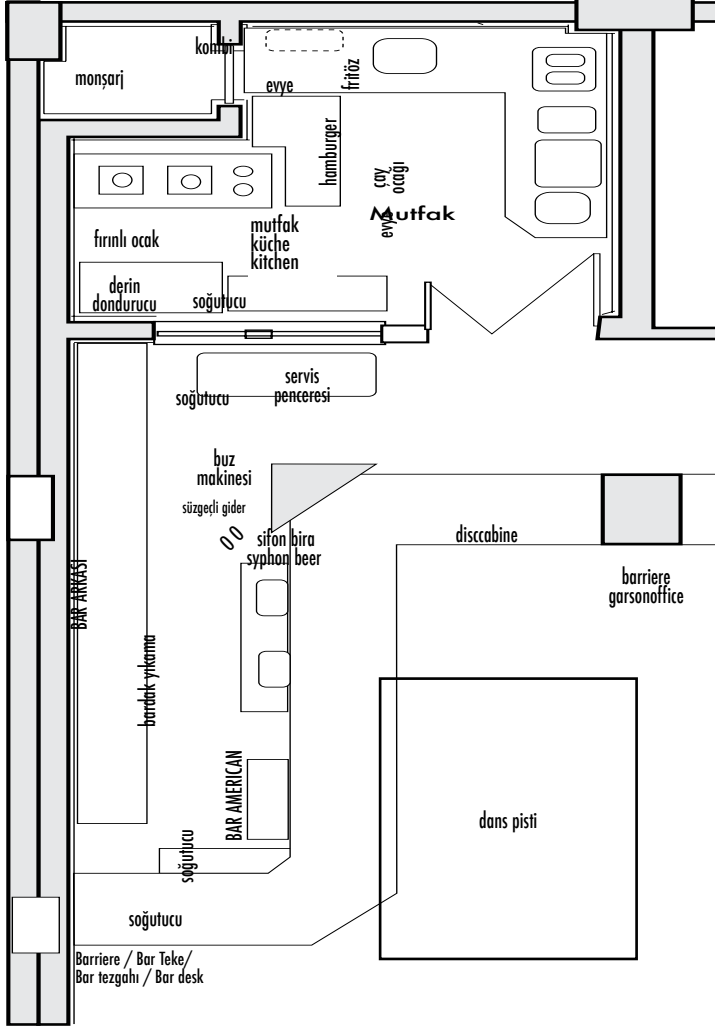

# BAR PLAN 04

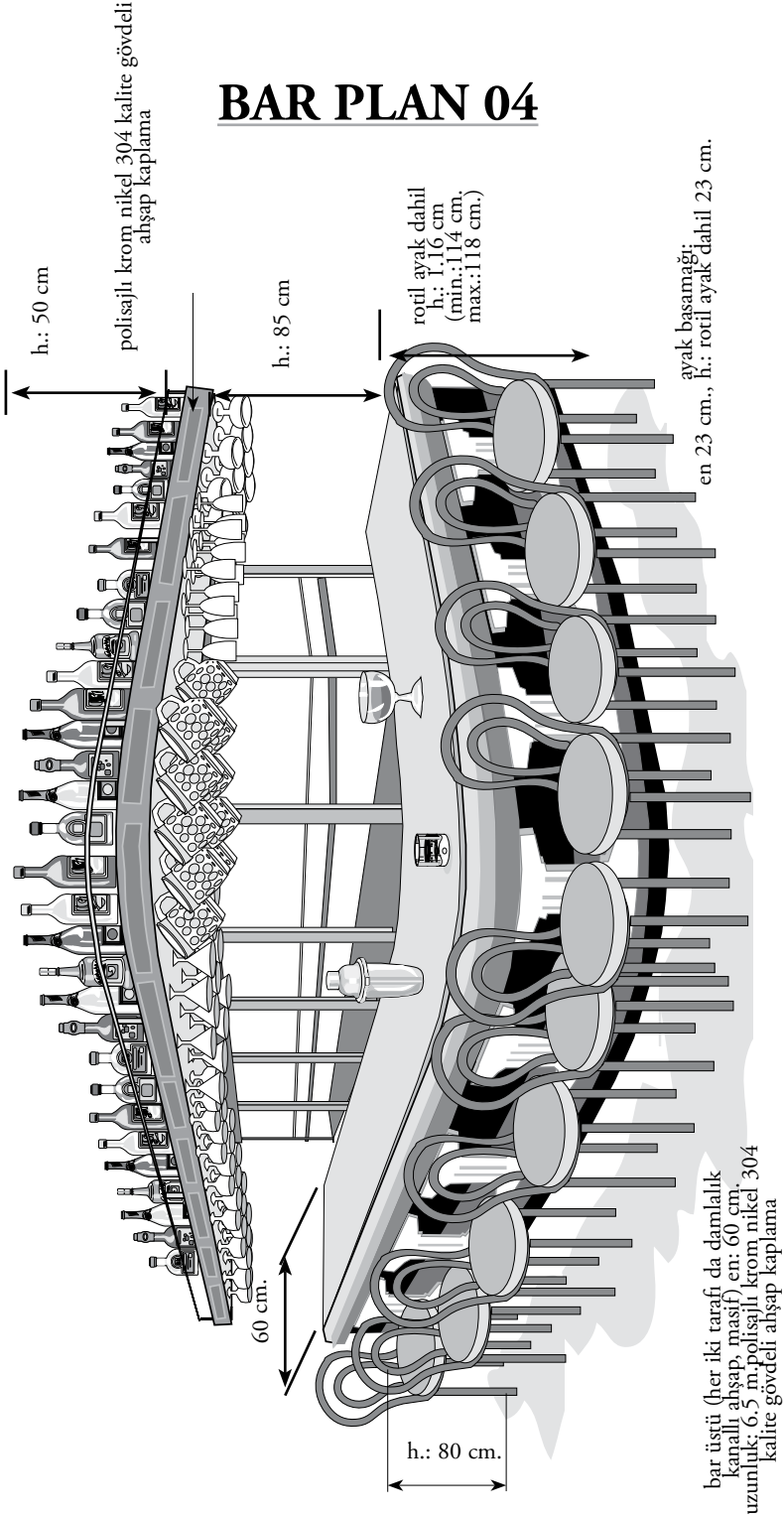



# BAR PLAN 05

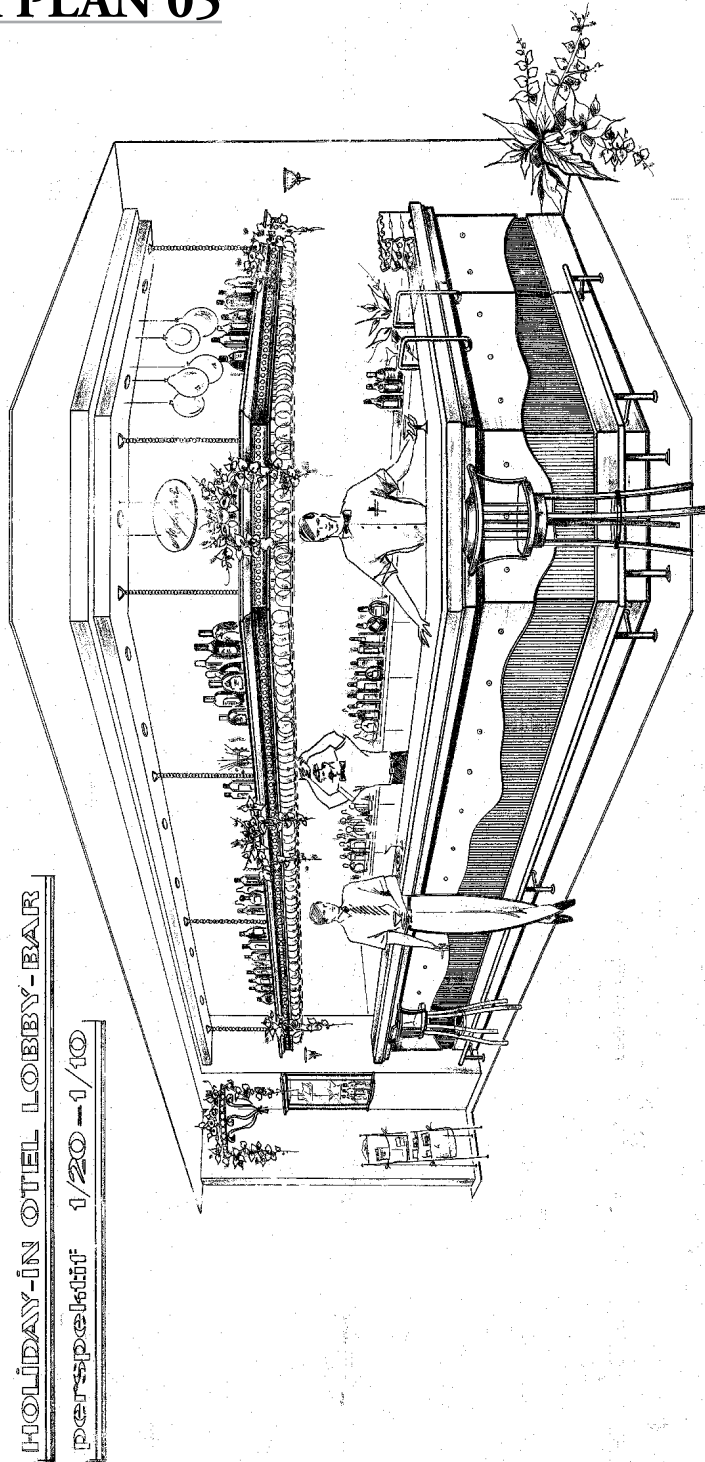

# BAR PLAN 06

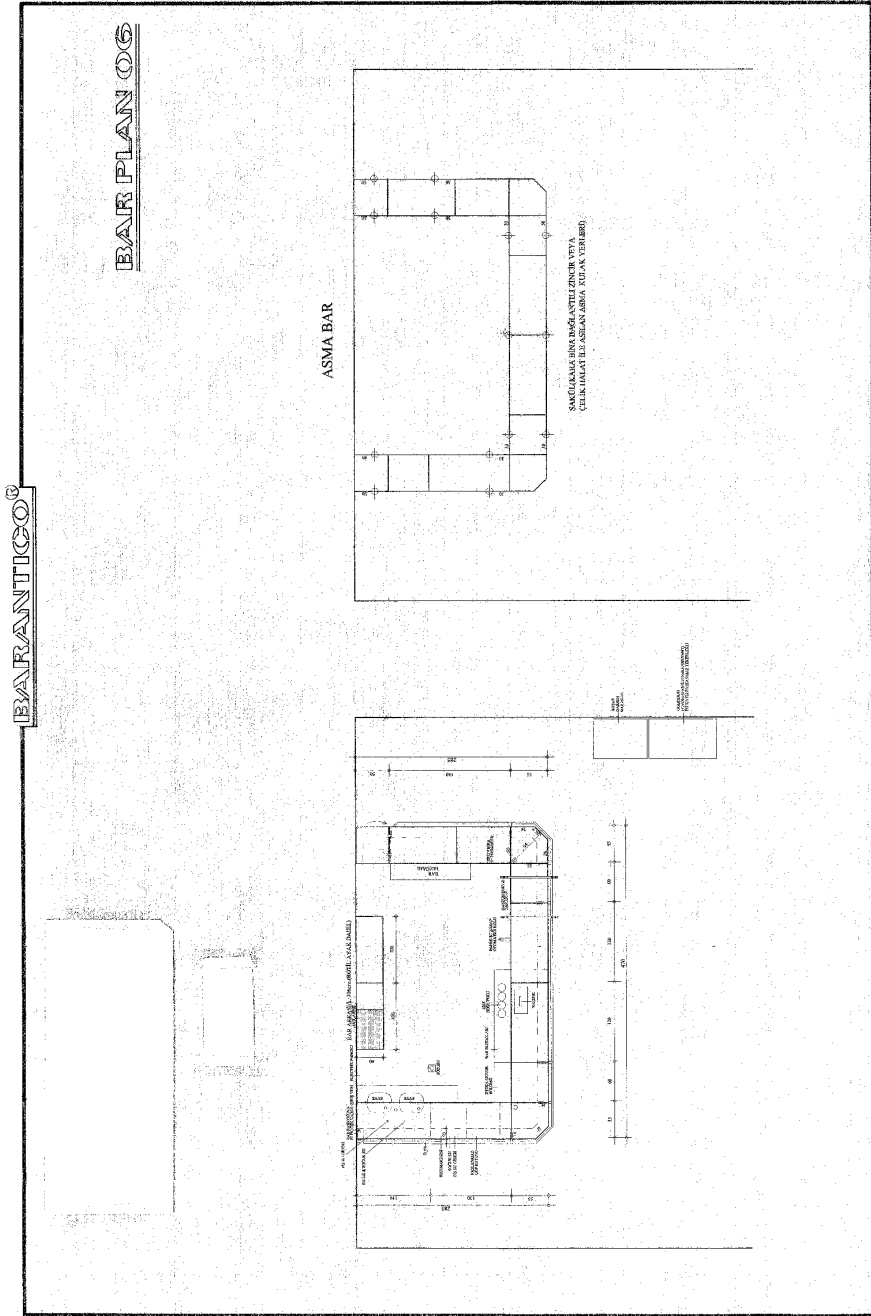

# BAR PLAN 07

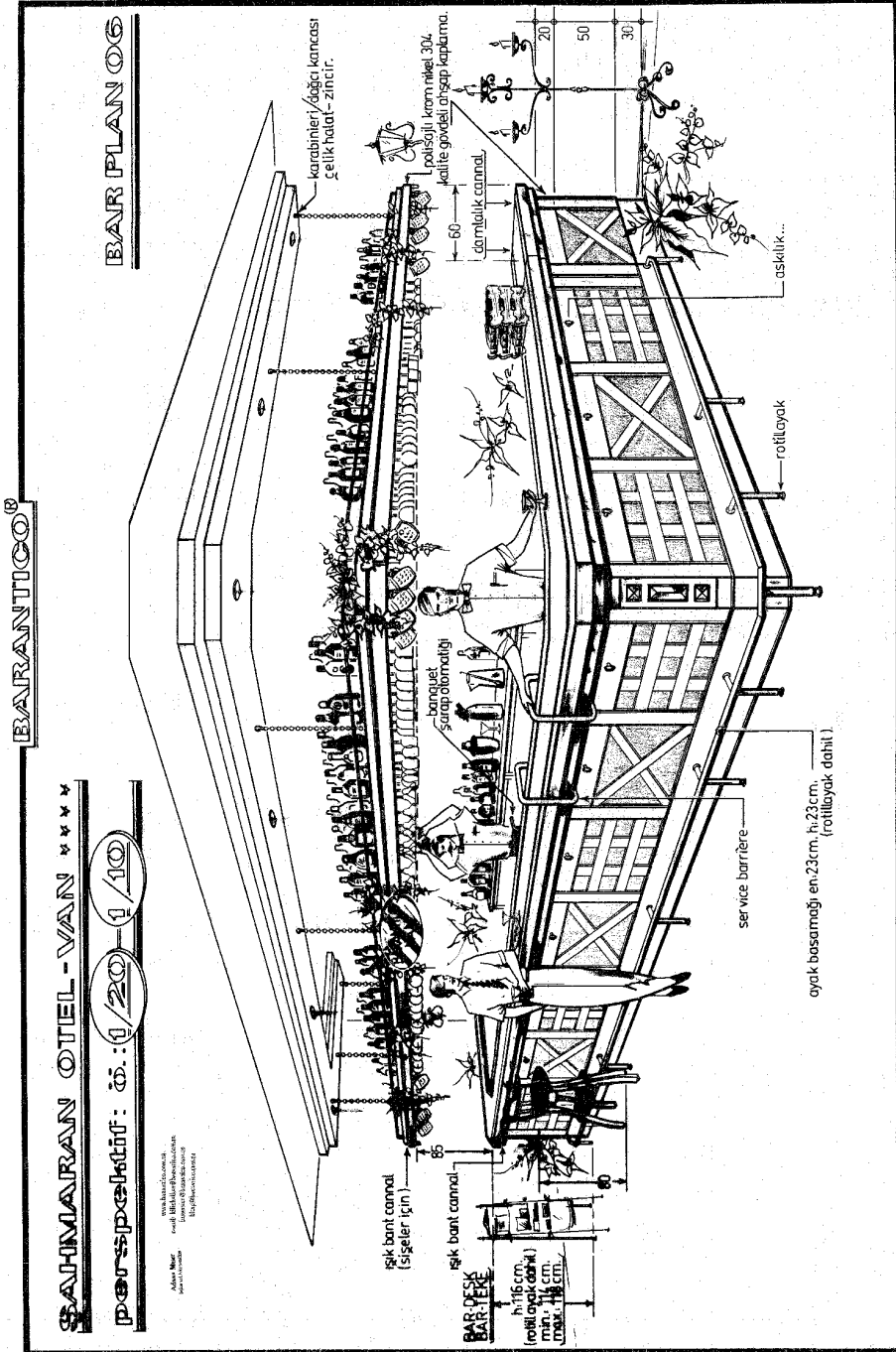

# BAR PLAN 08

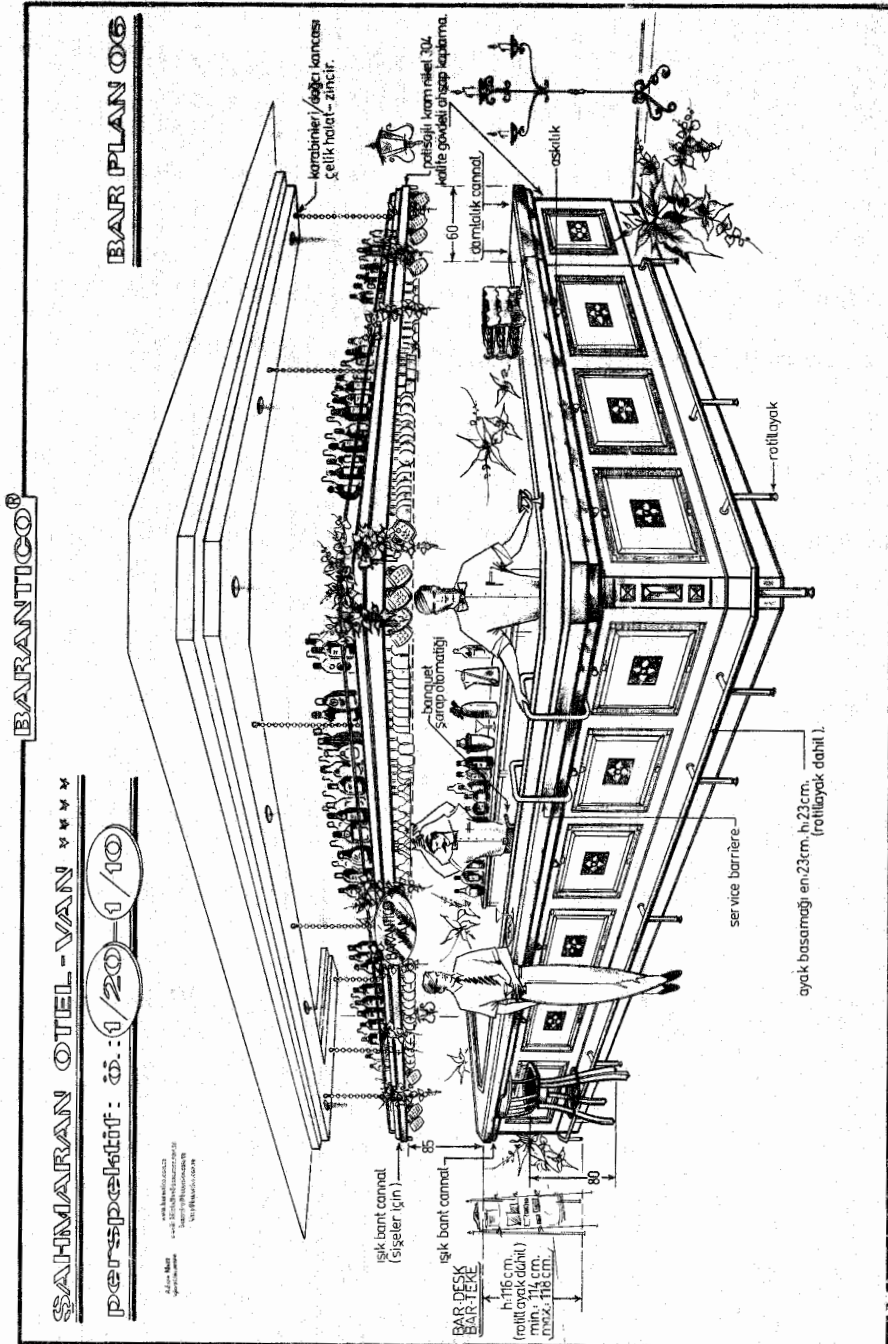

# BAR PLAN 09

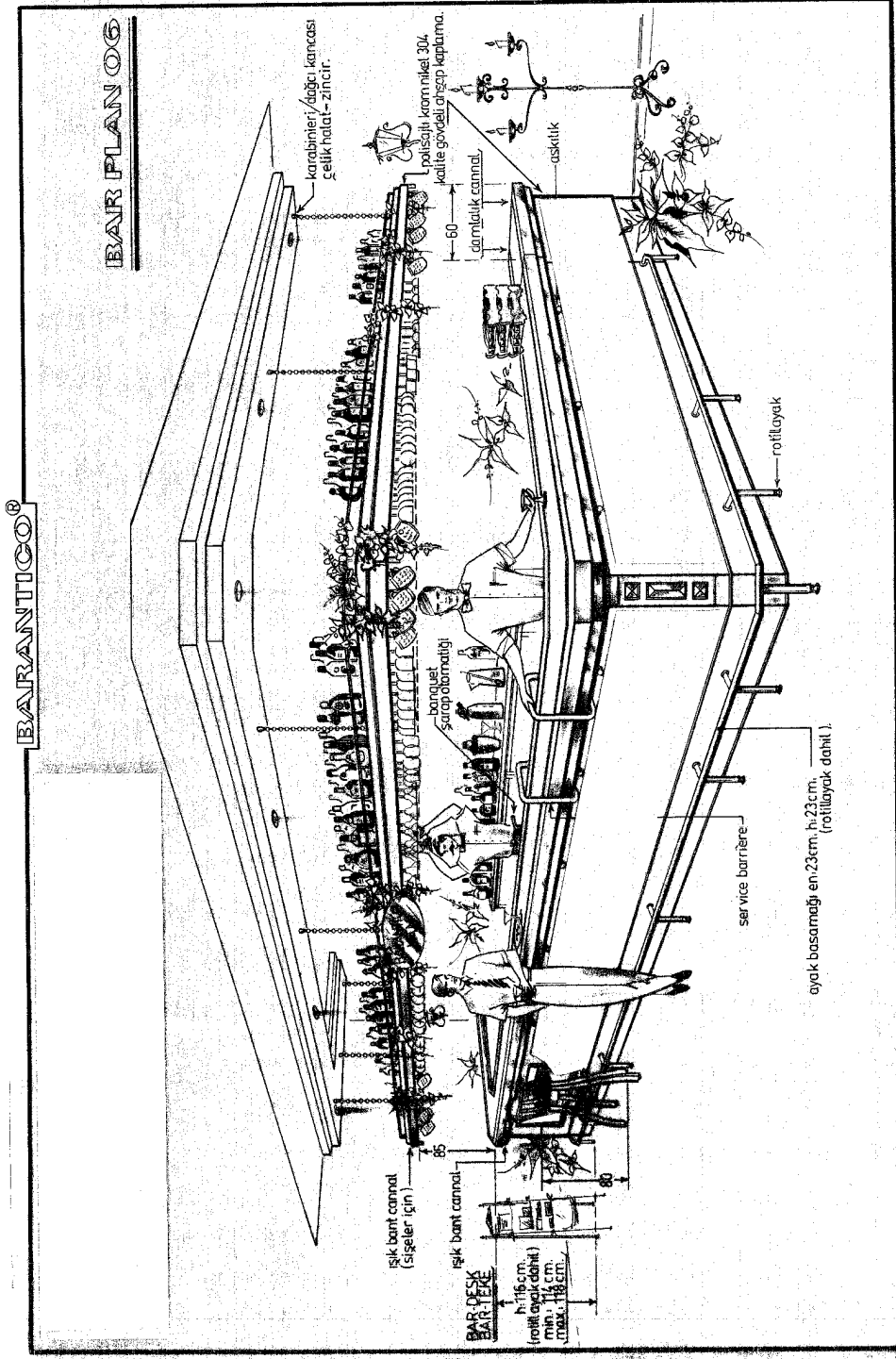

BAR PLAN 10  
TRAMWAY ÇAY BAHÇESİ - BURSA

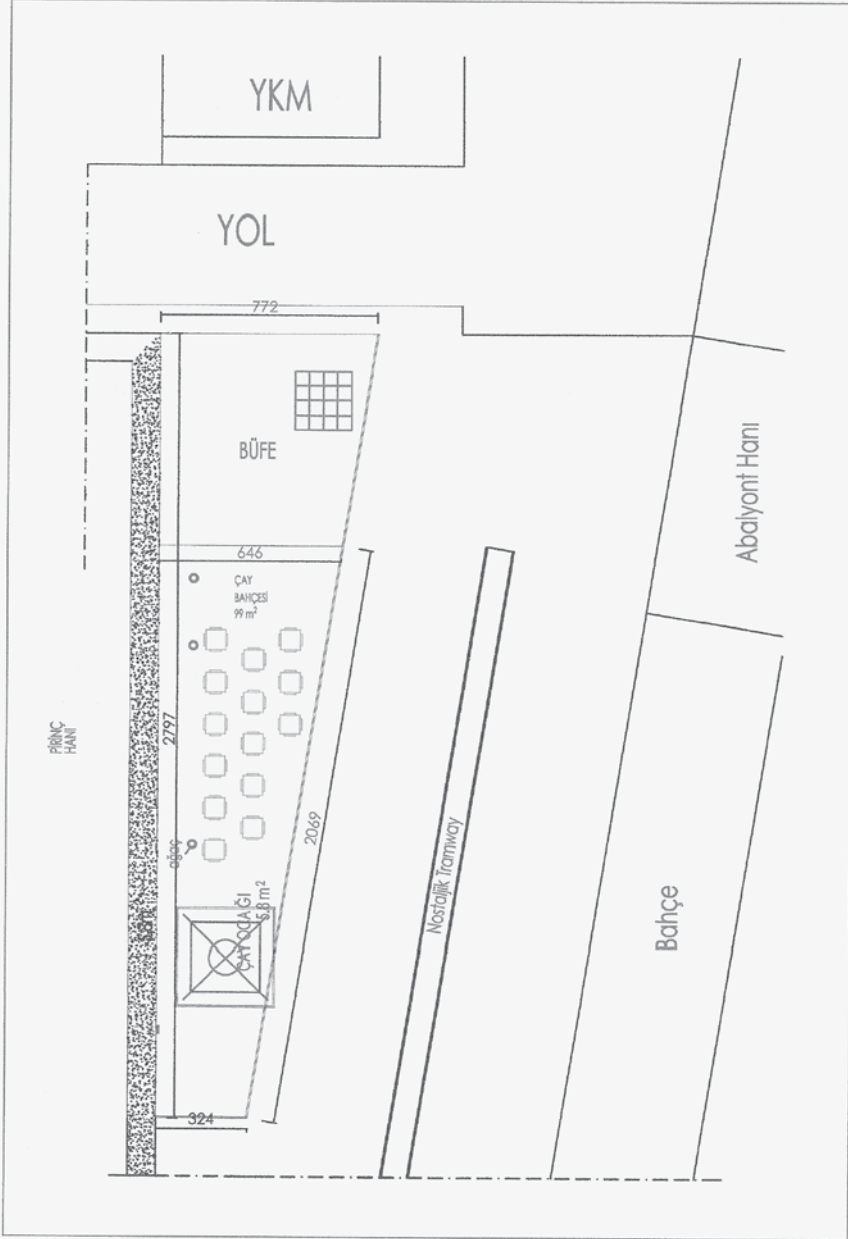



BAR PLAN 10  
TRAMWAY ÇAY BAHÇESİ - BURSA

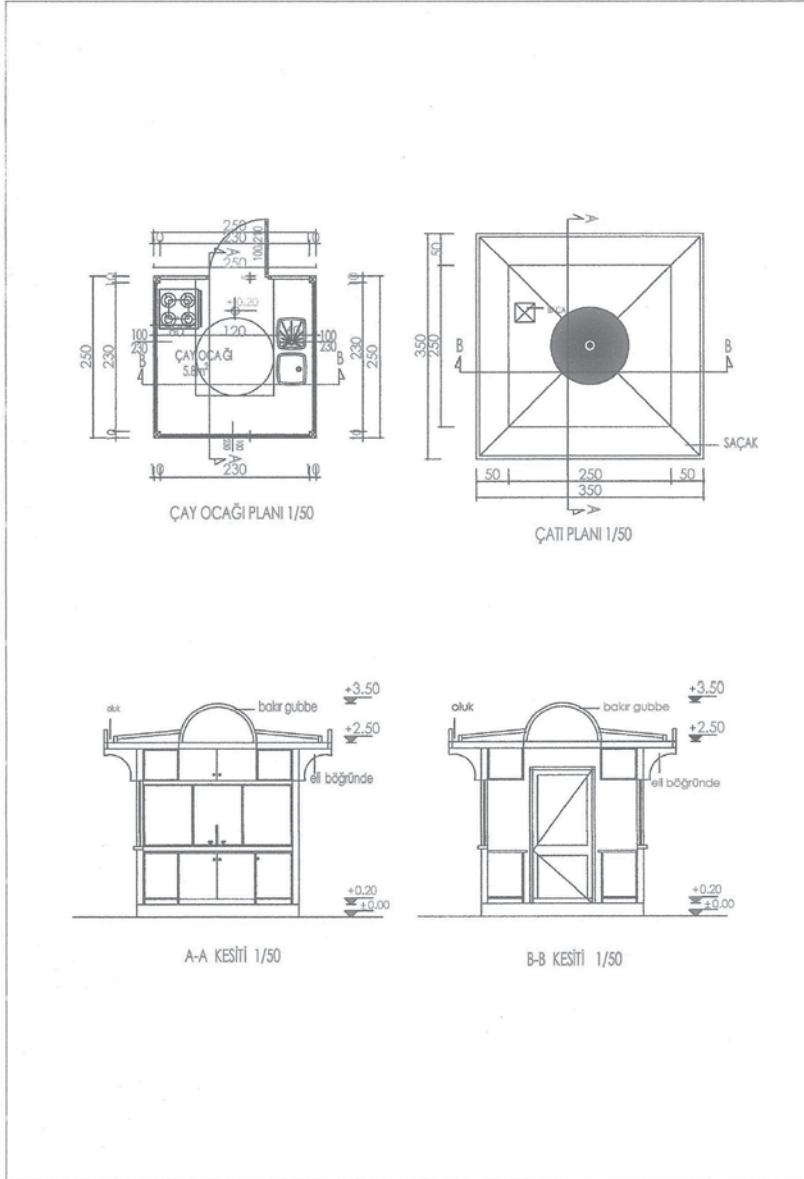

BAR PLAN 10  
TRAMWAY ÇAY BAHÇESİ - BURSA

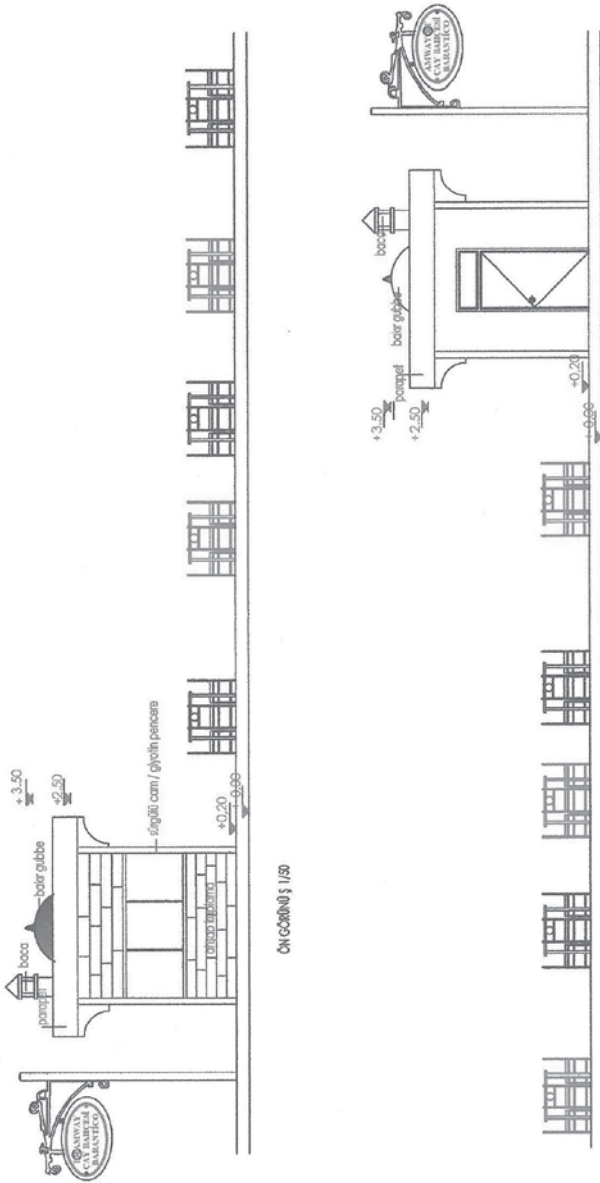

ON GÖRÜNÜŞ 1/50





## INTERNATIONAL PROTOKOL TABLE / TAFEL, TISCH / SOFRA, MASA-FORM'LAR

Tüm formlar kapı girişine göre düzenlenmiştir.

**P.:** President / protokol bşk.

### block / block / blok-form

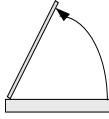
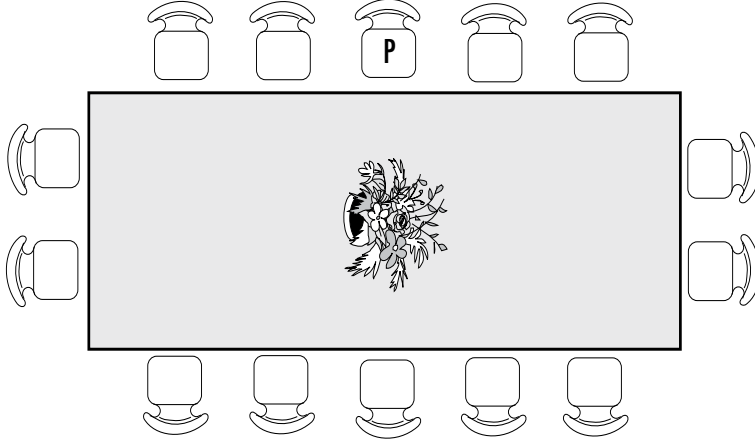

entrance  
entry  
Eingang  
giriş

### long table / lange tafel, tisch / uzun masa, sofr-a- form

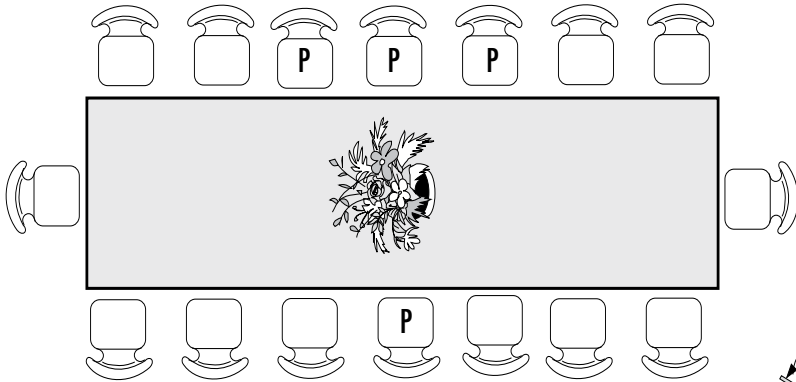

entrance  
entry  
Eingang  
giriş



E- table / E- tafel, tisch / E- masa, sofr-a form

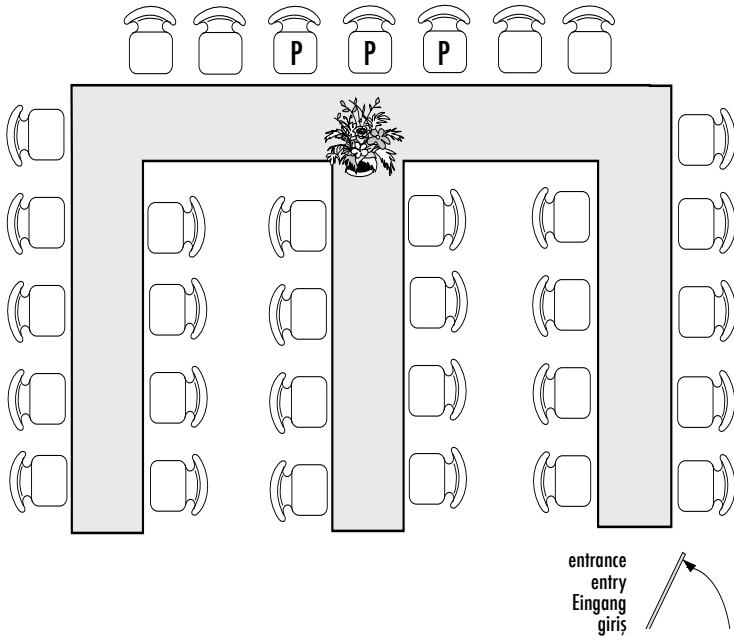

U- table / U- tafel, tisch / U- masa, sofr-a form

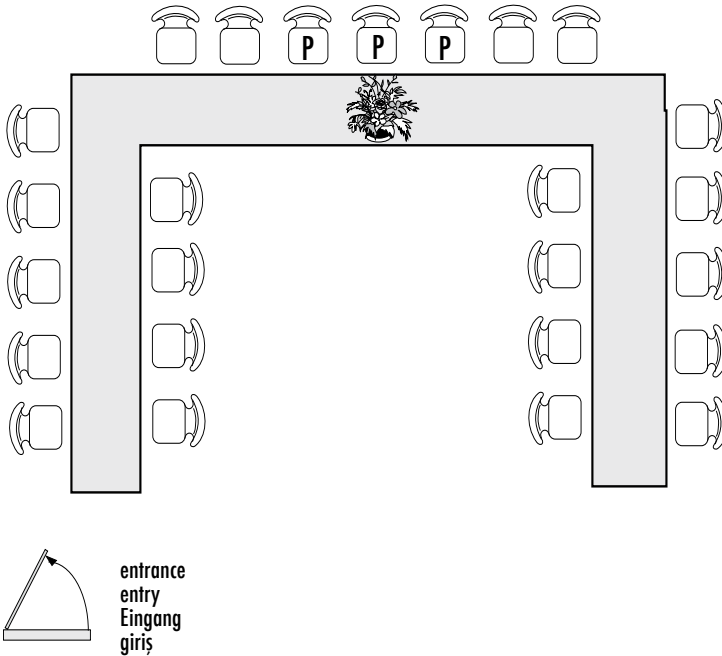

T-table / T-tafel, tisch / T-masa, sofr-a- form

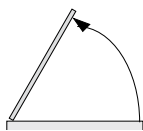
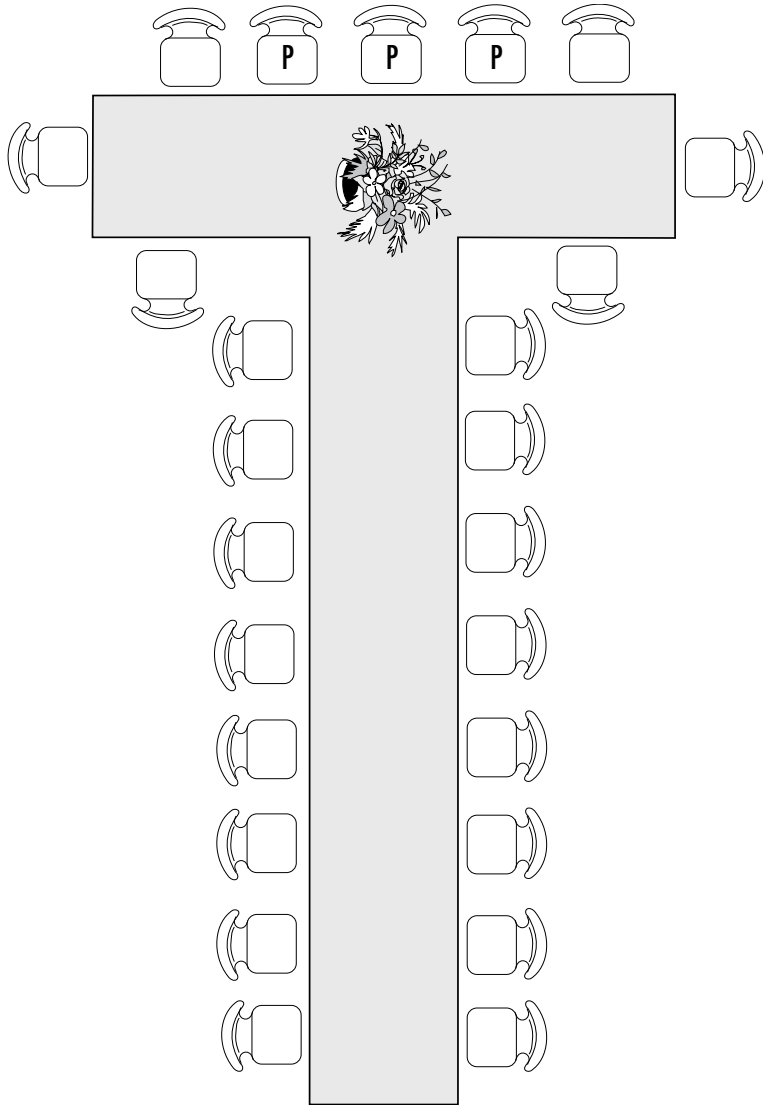

entrance  
entry  
Eingang  
giriş



**PEÇETE KATLAMA / NAPKIN TO FOLD, NAPKIN FOLDEN,**  
**TO PLAIT, TO RUFFLE / SERVIETTEN FALTEN**

01

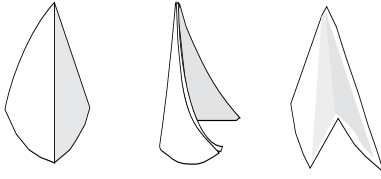
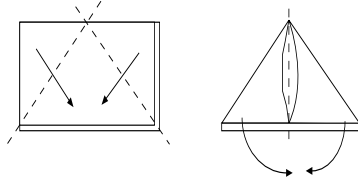

üçü şekli

02

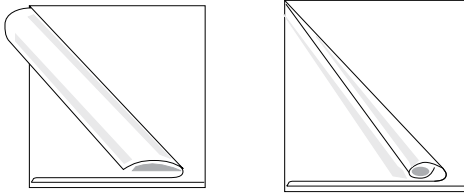
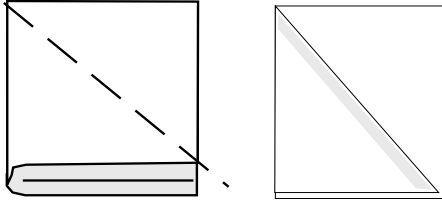

kıvrık köşeli kare

03

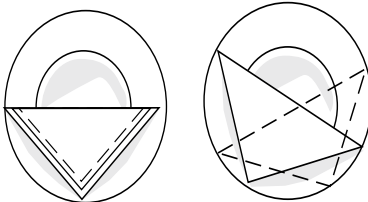
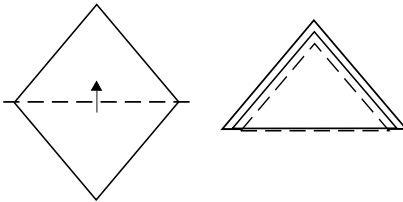

dreieck / üçgen



04

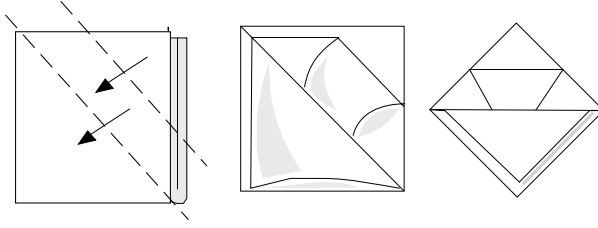

05

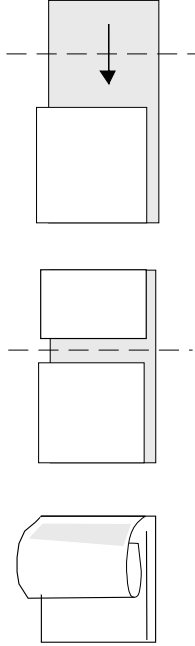

tekli dalga / merdiven

06

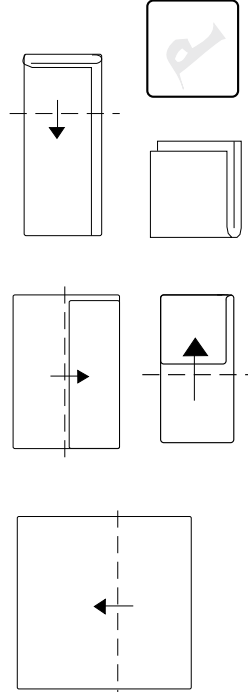

ikili dalga / merdiven

07

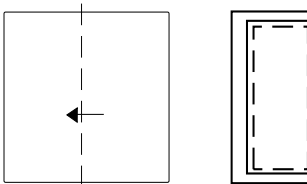

dikdörtgen

08

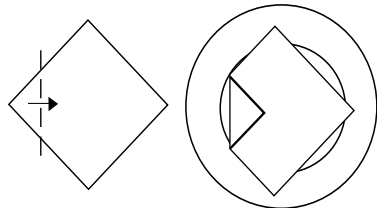

kıvrık köşe



09

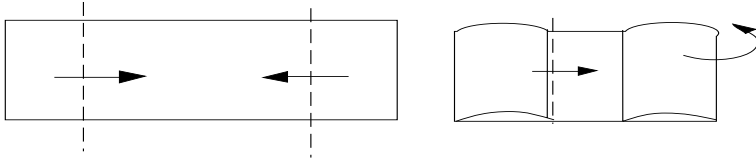

3' lü dalga, merdiven / 3 welle / 3 wave

10

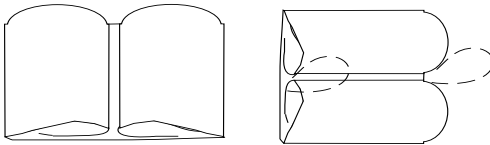
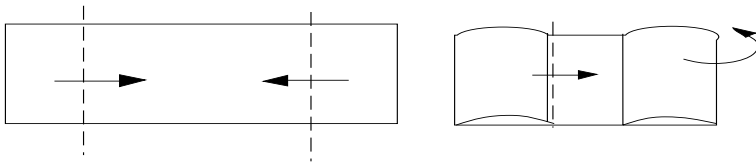

2' li dalga, merdiven / 2 welle / 2 wave

11

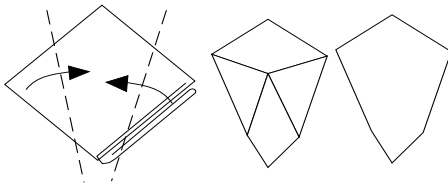
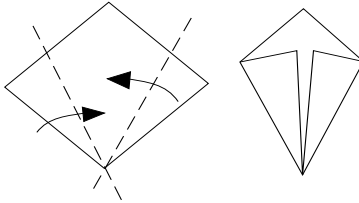

shield / kalkan

12

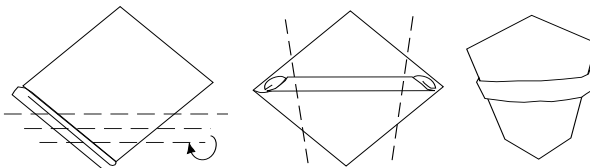

tasche / cep



13

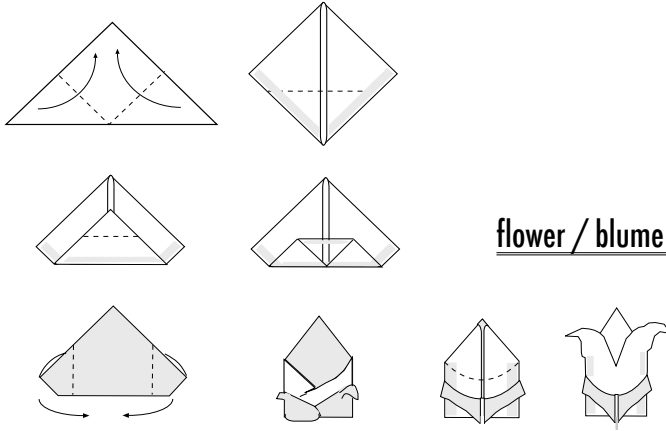

flower / blume / çiçek

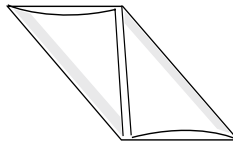
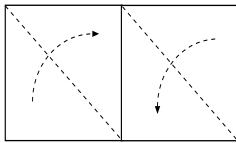

bishops cap, mitre / bischofsmütze /  
piskopos, papaz kepi, kasketi (1)  
"simple, plain / einfache / tekli"

14

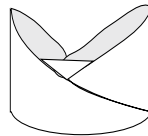
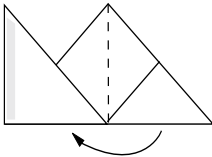
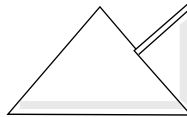
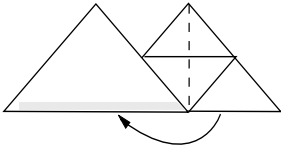
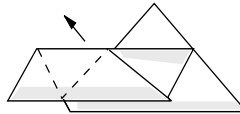
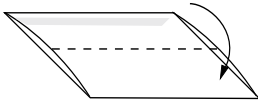

15

bishops cap, mitre / bischofsmütze /  
piskopos, papaz kepi, kasketi (2)  
"simple, plain / einfache / tekli"

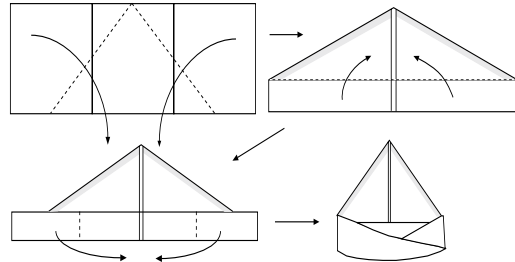

16

French pomeranian / Französischer spitz / Fransız sivrisi / French rest. style

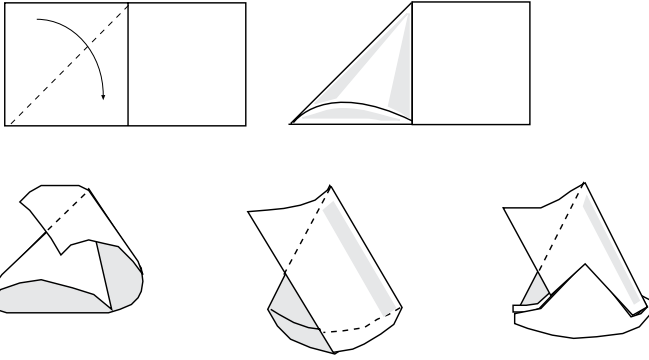

17

einfacher aufsteller / sade dik yerleştirme

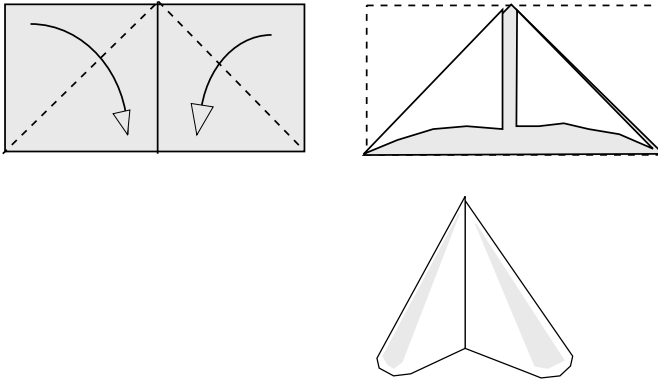

18

2 pomeranian / 2 spitz / 2'li sivri (masa sivrisi)

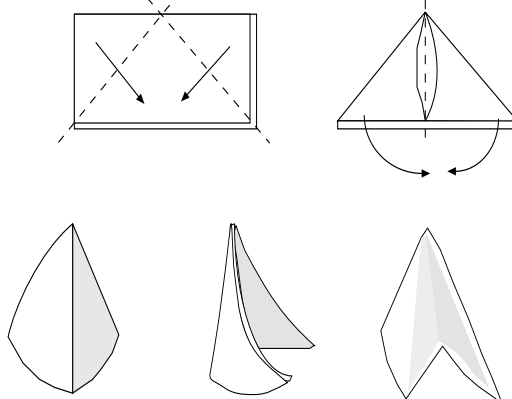

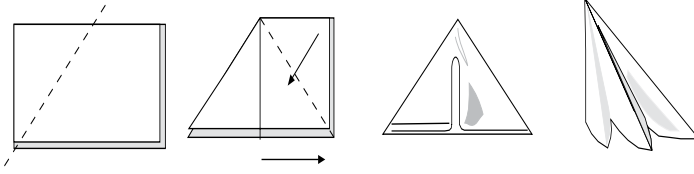

19

3 pomeranian / 3 spitz / 3'lü sivri (masa sivrisi)

20

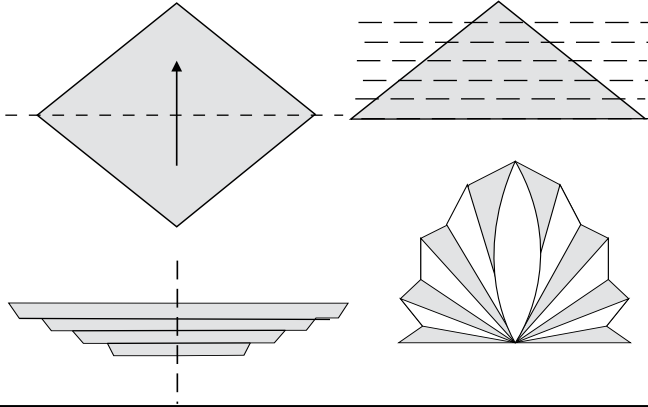
palm fan / palme fächer / palmiye yelpazesi

21

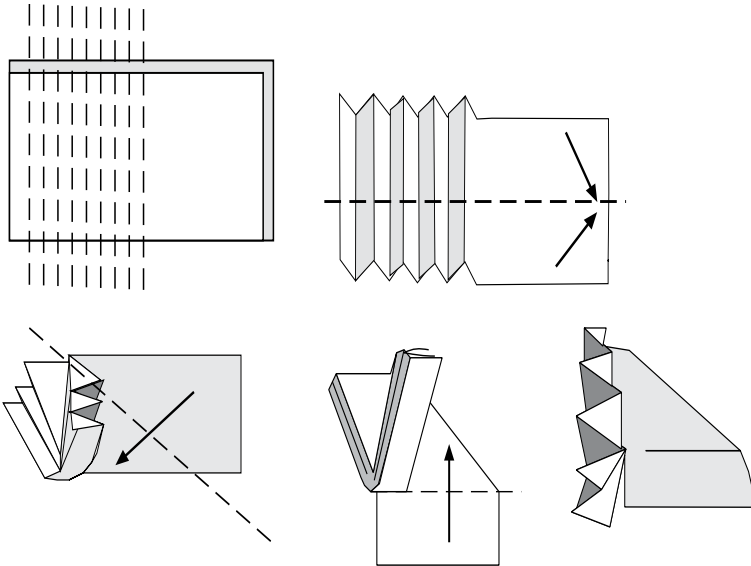
fan / fächer / yelpaze (ayaklı, tek basamaklı)

22

fan / fächer / yelpaze (ayaklı)

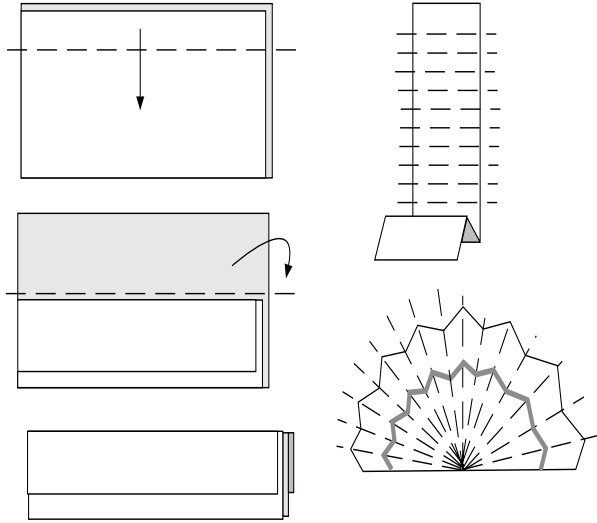

23

3' fan / 3' fächer / yelpaze (3 basamaklı)

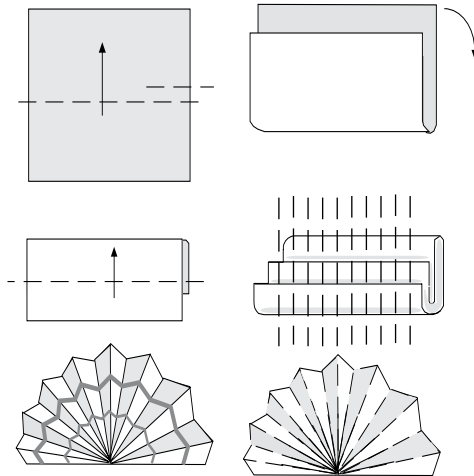

24

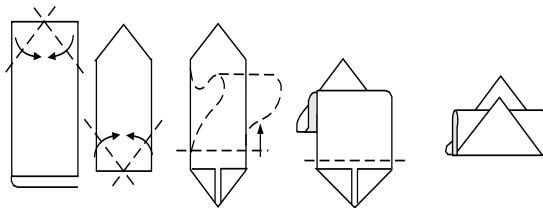

wave / welle spitze / dalga tepesi



25 star / stern / yıldız yelpaze

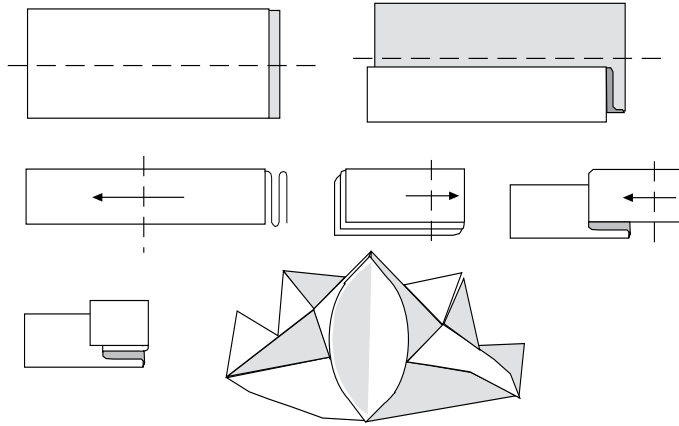

26 English style / lale

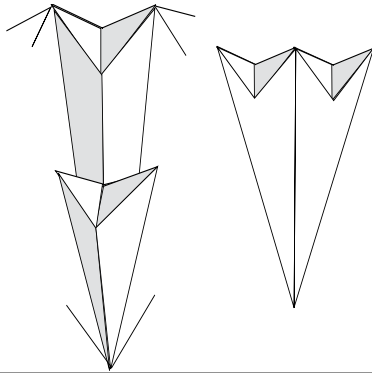

27 28 duplicate pocket / doppeltasche  
duble, çift cep

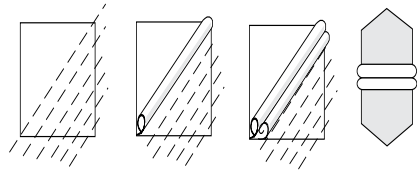

28 bud, burgeon / knospe / tomurcuk  
(blossom / blüte)

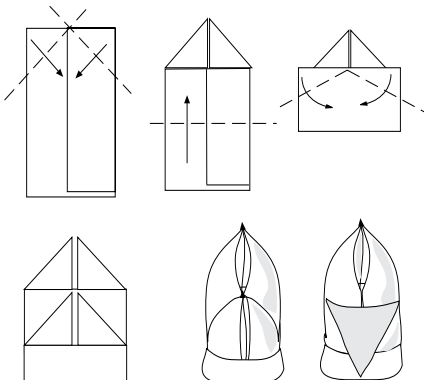

29 artichocke / artischocke / enginar /  
artichaut / rosé / gül

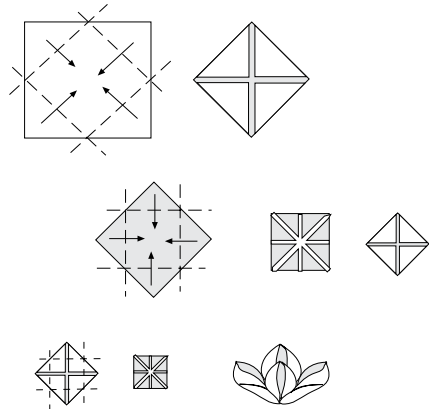

## GLASSES / GLÄSER / BARDAKLAR- FORM

01

water, wine,  
beer, or  
champagne  
glass.  
wasser, wein,  
bier oder sekt  
glas.  
su, şarap, bira  
veya şampanya  
bardağı.

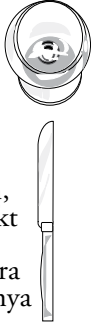

02

red wine / rot wein /  
kırmızı şarap

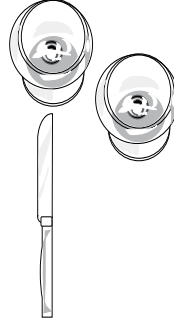

white wine /  
weißwein / beyaz  
şarap

kırmızı şarap bardağı / kadehi her zaman daha büyük olan formdadır. Akademik olarak kırmızı şarap bardağına / kadehine şarap doldurulduğunda, şişeyi sağa doğru çevirip kaldırırken şarabın son damlası masa örtüsüne düşmemeli, damla şişe üzerinden aşağı doğru süzülürken peçete ile müdahale edilmelidir. Buna rağmen masa örtüsüne kırmızı şarabın damlası düşmüşse "kapak örtü" ile çözümlenir.

03

champange,  
sekt,  
şampanya

red wine /  
rotwein /  
kırmızı şarap



white wine /  
weißwein /  
beyaz şarap

04

red wine / rot wein /  
kırmızı şarap

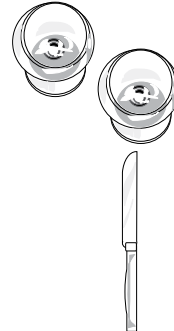

white wine /  
weißwein / beyaz  
şarap

05

champange,  
sekt, şampanya

red wine /  
rotwein /  
kırmızı şarap



white wine /  
weißwein / beyaz  
şarap

06

champange,  
sekt, şampanya

red wine /  
rotwein /  
kırmızı şarap

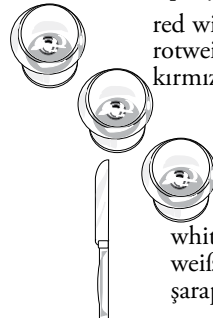

white wine /  
weißwein / beyaz  
şarap



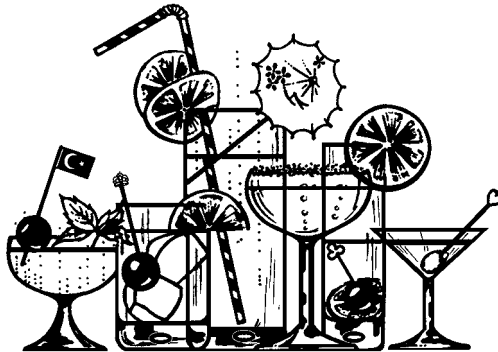
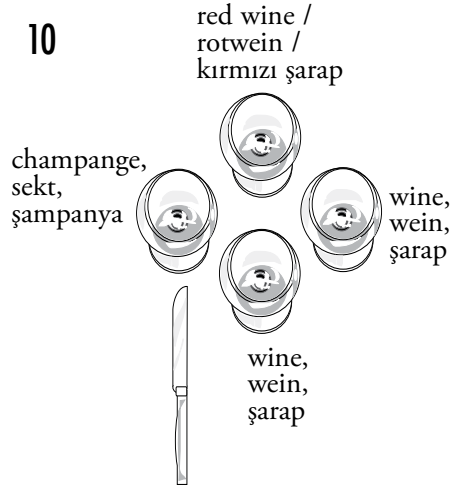
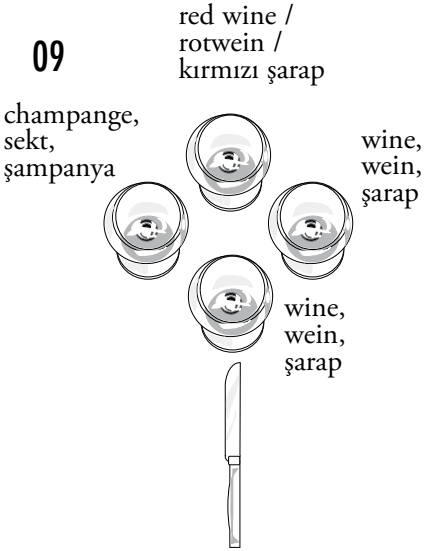
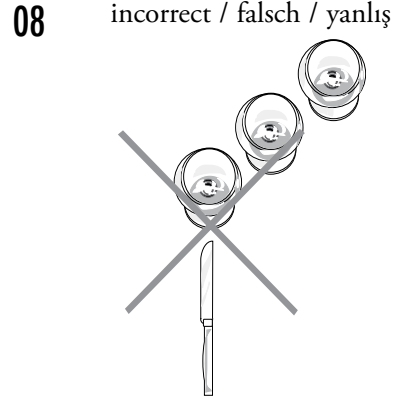
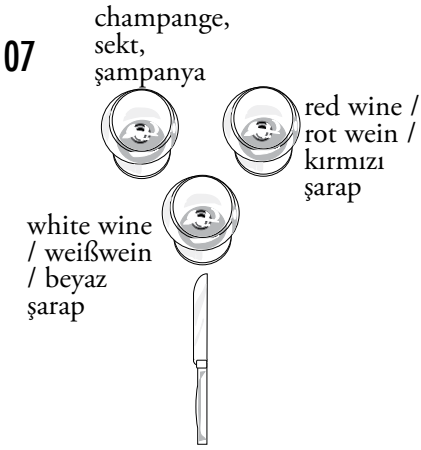

MENU COVER-FORM

MENU GEDECKT, DECKEL / KUEVER-FORM

kuver: Ç.K.B. takımı (çatal, kaşık, bıçak)

01  
fish soup  
balık çorbası  
fischsuppe  
bouillabaisse

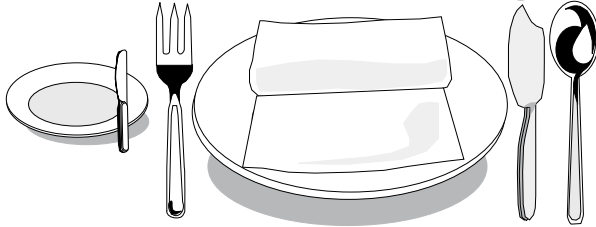

02  
meat soup  
etli çorba  
fleischsuppeneintopf  
pot-au-feu

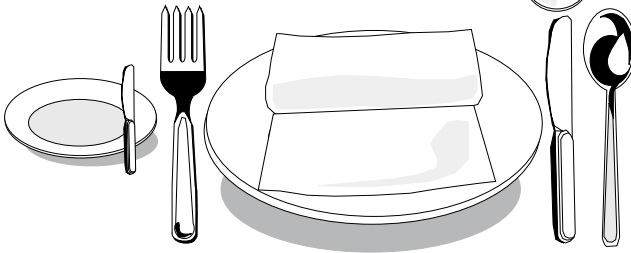

message / mesaj:

İçki servisi, çorba servisinden çorba bitinceye kadar yapılmaz !  
Herkesin ekmek & salata tabağı solundadır. Müşterilerden birisi sol tarafi yerine sağ taraftan salata veya ekmek tabağı kullandığında masa düzeni bozulur.

**03**  
**hors-d'œuvre**  
**ordövr**



**04**  
**portion kaviar**  
**porsiyon havyar**

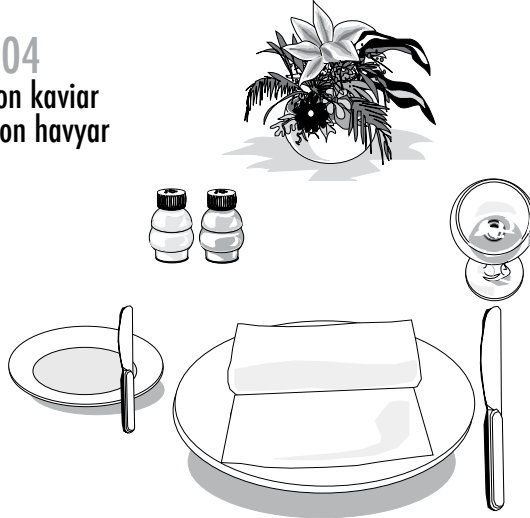

05

caviar on toast or  
with blinis  
kaviar auf toast oder  
mit blinis  
havyarlı tost, blinisli



06

smoke salmon  
räucherlachs  
somon fümé  
fumée lachs



message / mesaj:

ana yemek yanına salata varsa / istenilirse soldan hafifçe salata servisi yapılırken parmaklarınızla soldaki ekmek & yağ tabağını yukarı doğru sürerek aynı yere salata tabağı konulur !





07  
salmon fish  
seräucherter fisch  
allgemein  
füme somon balığı  
poisson saumon

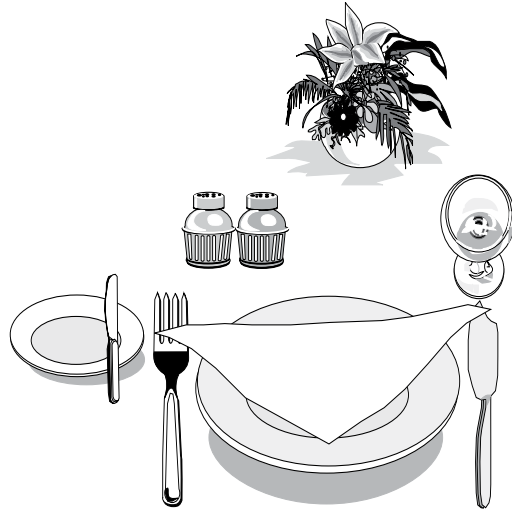

08  
asparagus  
spargelstangen  
kuşkonmaz  
asperge

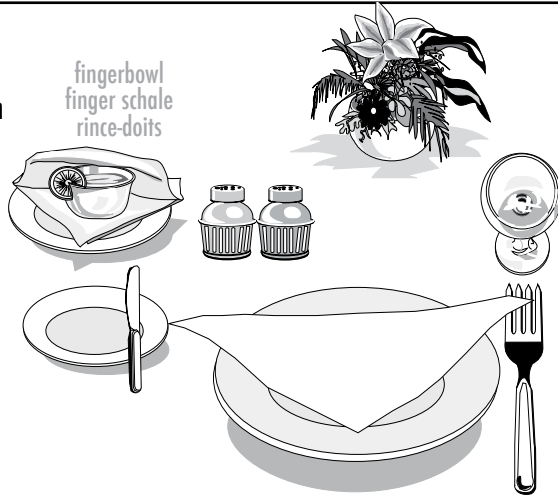

09  
asparagus  
spargelstangen  
mit rohschinken  
kuşkonmaz  
asperge

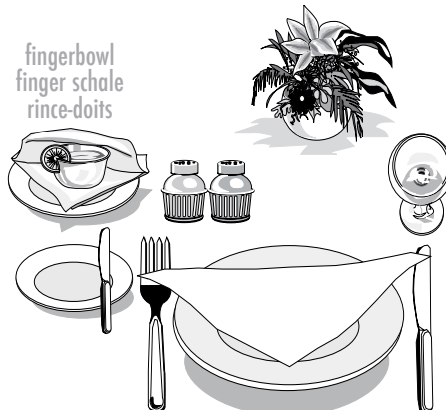

10  
artichoke  
ganze artischocken  
bütün enginar  
artichoke  
artichaut

fingerbowl  
finger schale  
rince-doits

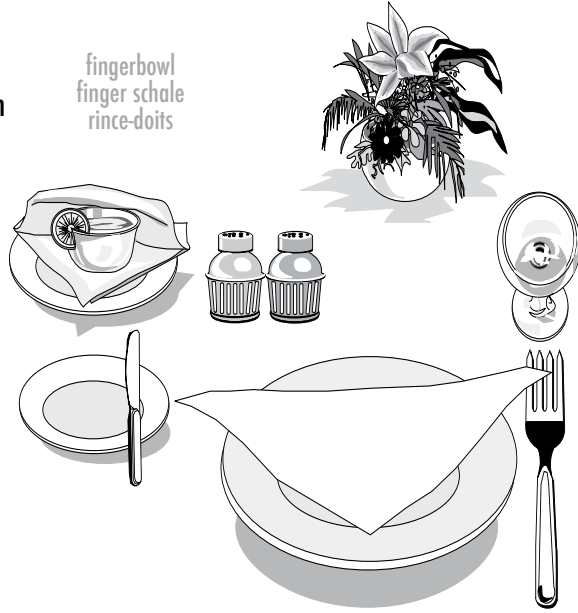

11  
1/2 melon  
1/2 melone  
1/2 kavun

fingerbowl  
finger schale  
rince-doits

şekerlik  
sugar  
zucker

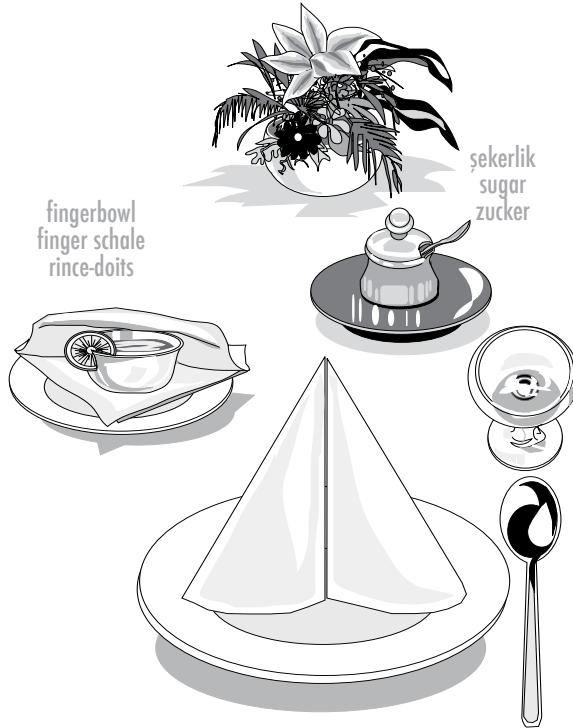

12  
tranche melon  
melonenschnitz  
kesme/dilim kavun



şekerlik  
sugar  
zucker

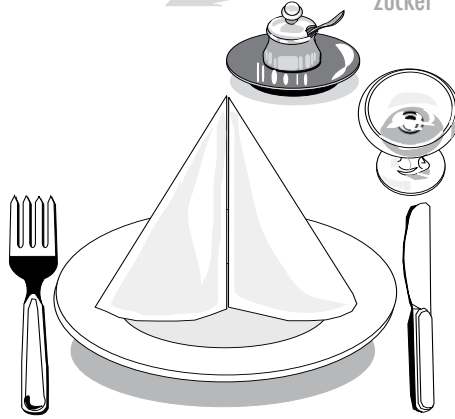

13  
melonenschnitz mit  
rohschinken  
kesme/dilim kavun  
ile rulo  
jambon  
roll ham

şekerlik  
sugar  
zucker

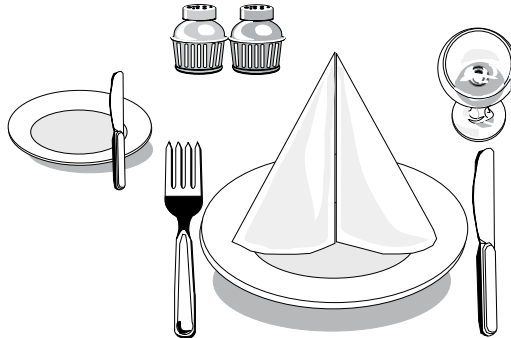

14  
peach  
pfirsich melba  
im kelch serviert  
şeftali  
pêche

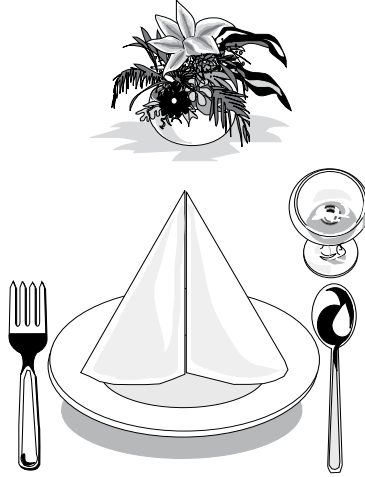

15  
sweets, desserts  
andere süßspeisen  
im kelch serviert  
diğer tatlılar

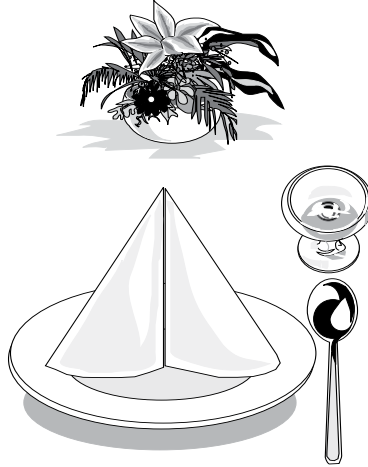

16  
fruit salad  
fruchtsalat, himbeeren,  
erdbeeren,  
heidelbeeren usw.  
(raspberries, ahududu,  
ağaç çileği / framboise,  
strawberries, çilek,  
fraise, billberries, blue  
berries / yaban mersin  
çileği / myrtille) etc.  
meyve salatası, çilekli,  
dağ çilekli  
entremet  
salade de fruits

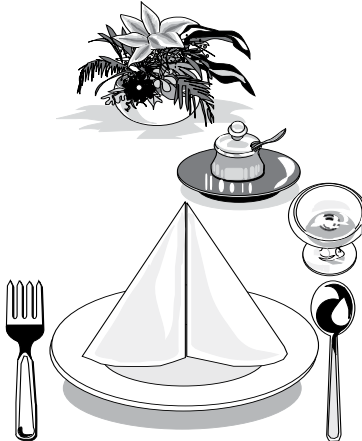

17  
single, simple menu  
einfaches  
grundgedeck  
sade menu, kuver

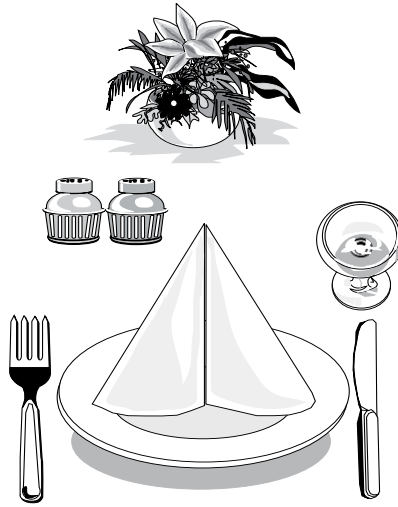

18  
menu  
grundgedeck  
à la carte  
nach der karte  
kart tarzı menu

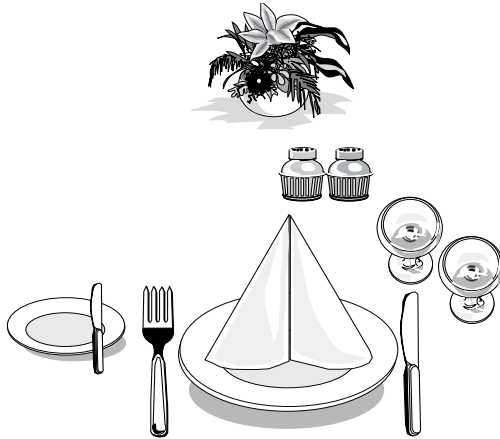

19  
oysters  
austern  
midye  
huîtres

fingerbowl  
finger schale  
rinçe-doits

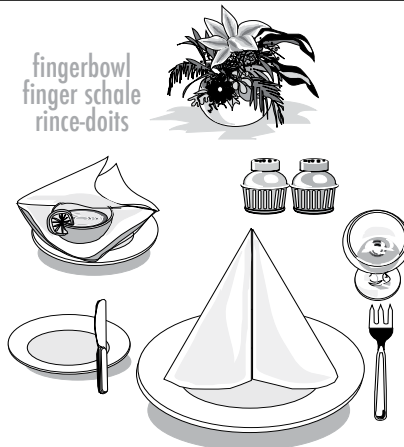

20  
Cocktail from  
cruste, croûte  
Cocktail von  
Krustentieren  
kabuktan kokteyl

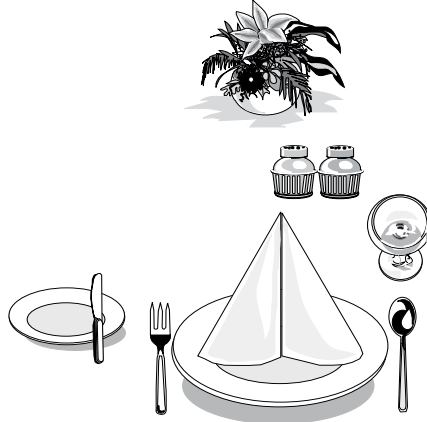

21  
colder lobster,  
homard  
kalter hummer  
soğuk istakoz



22  
omelette,  
mehlspeisen,  
teigwaren,  
reis & gemüse  
unlu yemek, hamur  
işleri, omlet,  
pirinç & sebze



23  
gooseliver  
gänseleber  
kaz ciğeri  
oie foie



24  
cheese  
käse  
peynir  
fromage

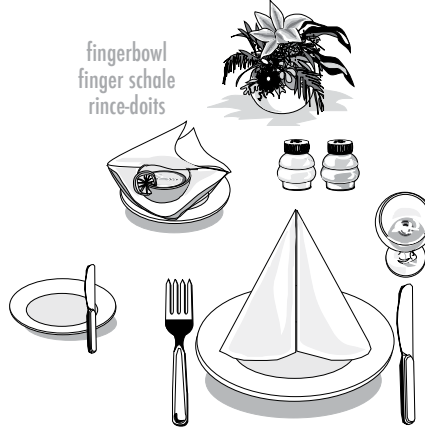

25  
Fruit basket,  
corbeille, panier  
Früchtekorb  
meyve sepeti



26  
 grape fruit  
 grapefruit  
 greyfurt  
 pamplemousse

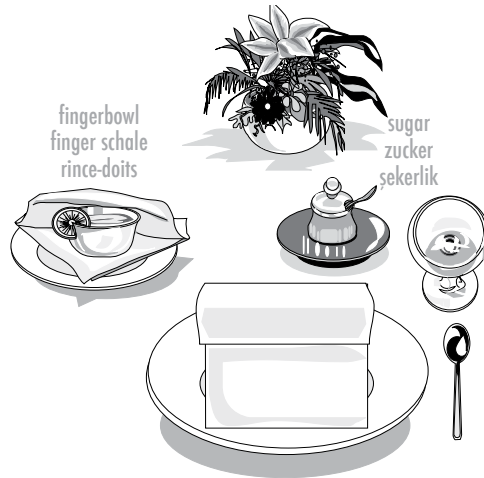

27  
 Snail  
 Schnecken  
 Sümüklüböcek  
 ascargot



28  
 hind-leg of a frog /  
 grenouille  
 Froschschenkel  
 kurbağa budu





29

clam, mussel  
muscheln nach  
seemannsart  
midyeler &  
deniz ürünleri  
moules  
marinière

fingerbowl  
finger schale  
rince-doits



30

menu mit  
hors d'œuvre,  
kraftbrühe / clear  
soup / consommé  
fleisch /  
nachtsch / dessert,  
sweet fish  
ordövrü menu  
balık, tatlı (dessert)

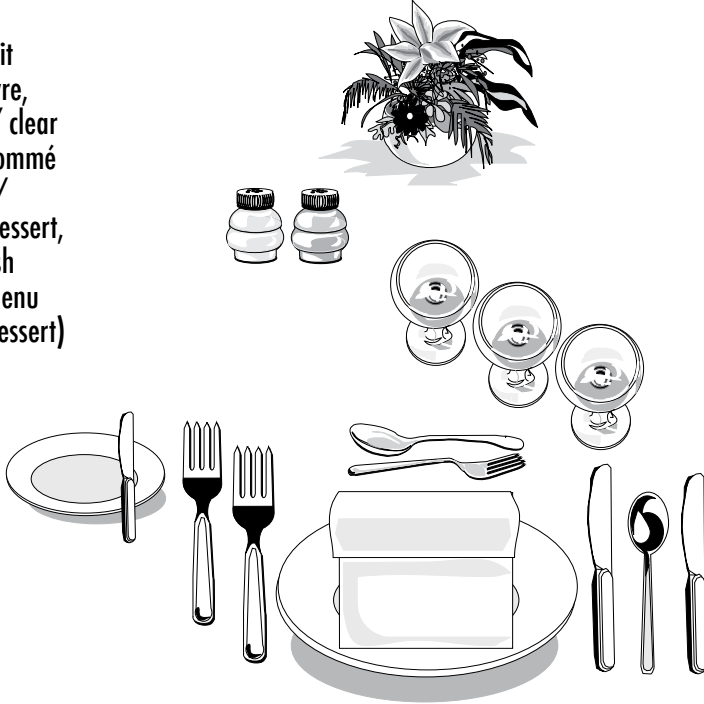

Ana yemek bittiğinde nachtsch / dessert / tatlı gelmeden önce mutlaka masadan ekmeđ tabađı, .k.b. takımı ile ekmeđ sepeti , tuz - biber kaldırılmalıdır. !



31

menu mit suppe,  
fisch, fleisch  
(hauptgang), çorba,  
balık, et (ana  
yemek),  
nachtisch /dessert.

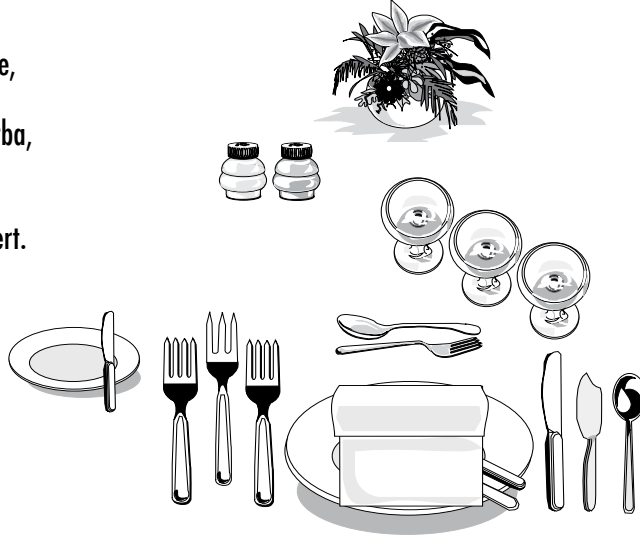

32

für vorspeise  
suppe, fisch  
zwischengericht,  
fleisch, dessert  
önyemek, çorba,  
balık, arayemeği  
(zeytinyağlı et &  
tatlı için)

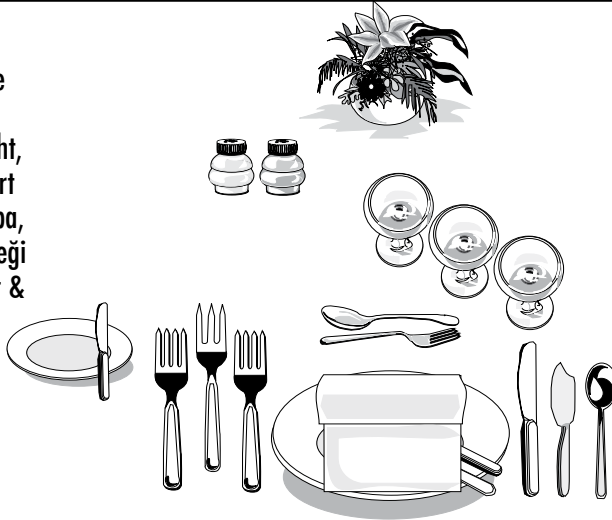

Yukarıda görüldüğü gibi ekmeğ tabağı varsa, salata tabağı da ana yemek yanında servis edilecektir, garson salata tabağını soldan koyarken hafifçe ekmeğ tabağını yukarı sürüp yerine salata tabağını koyacaktır, bu sistem tüm servislerde aynıdır.

33

mesaj / message to chef de rang /  
waiter: tabağı kaldırabilirsiniz  
anlamındadır. /  
Sie können abreumen / abnehmen /  
to take over.

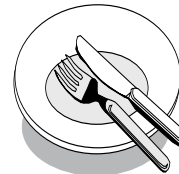

## RODOP KÖFTESİ'NİN TARİHÇESİ

Bulgaristan ile Yunanistan sınırının arasındaki Rodop dağlarından gelmektedir. Bu dağların üzerindeki Rodop Kasabasında yaşayan büyüklerimiz oradaki gastronomi / damak zevklerini / mutfak kültürlerini Türkiye'ye taşıdılar. 3. jenerasyon / generation Barantico tourism ltd. co. ile 3. kuşak rodop köftecisi chief Ahmet Dalgıç marka tescilini alıp Türkiye'ye mal ettiler! Rodop köftesi'nin ünü Bursa'dan Dünya'ya yayılmıştır. Rodop & inegöl köftesi kuzendirler. Kasap köftesi ise : Soğanı konulmamış 2 aşamadaki rodop köftesinin hamuruna 7 karışım baharat katılıp iyice yoğurulur. Huni ile basılmaz, soğan katılmaz, 1 porsiyon 6 adettir. (125 gr.)

Rodop köftesinin Kosovo & Bosna-ı Hercegovina (Sarajevo / Saraybosna)'daki adı çüfte/ köfte değil "kebab"tır! Köfteci ise "kebabchi" / kebaççı' dır. Kasap köftesinin daha büyüğüne de çüfte / köfte denilmektedir.

### **Rodop Köftesi Tarifi** ( gizli / geheim / secret ) " 4 kg. ete göre"

01- 4 kg. dana kaburgasından parça et alınır,

02- Çapı 32'lik ince diş ayna (kıyma makinesinin parçası) ile dana eti 1 defa çekilir. (uyarı 2 defa çekilmemelidir.)

03- 40 gr. karbonat, 40 gr. kalın yemeklik tuz, 400 gr. ekmek içi (2 günlük bayat beyaz ekmek)

Mis en place / vorbereitung / ön hazırlık :

04- Küçük tas içine ılık su ( yoğurma esnasında etin elimize yapışmaması içindir.), içinde yoğurmak için büyük paslanmaz çelik küvet,

05 - Üstteki hazırladığımız malzemeleri büyük bir tencereye koyup, yumruklarımız beyazlaşıp, etimiz sakız gibi oluncaya kadar yoğurulur.( veya teknoloji kullanılarak yoğurma makinesinde de yoğurulabilir. )

06- Et topak haline getirilip, çelik küvete konulup, üzeri streçlenir & 1 gün buzdolabında dinlendirilir. ( üflemele meşrubat dolaplarında dinlendirilmez.)

2. Gün

07- Dinlenmiş eti bu sefer 32 'lik kalın diş ayna ile 1 defa çekilir. ( son defa çekilir!)

Önceden satır ile inceltilmiş "soğan asla rendelenmez" 2 avuç soğan ile tekrar yoğurulur. ( 2 kg. ete 1 avuç soğan katılır.) " kırmızı soğan denilen acı Karacabey soğanıdır."

08- Özel köfte hunisi ile temiz & düz tepsiye parmak şeklinde basılır. ( etler / kıymalar 5 'erli sıralar halinde basılır.)

"1 kg. hazırlanmış kıymadan 8 porsiyon köfte çıkar & 1 porsiyon köfte 10 adettir. (130 gr.)"

Ustalık Belge / head- cook / küchencef nr.: 152 /A 160434 - 154 / A 160436

T.C. Türk Patent Enstitüsü Marka Tescil Belgesi no.: 2001 13732

T.C. Türk Patent Enstitüsü Marka Tescil Belgesi no.: 2002 24976



orijinal köfte maşası paslanmaz çelik 2x32 cm.  
tel köfte ilave şişi, hafif yassı 26 cm.





Salih Gjlanli - Emina Mathusha & oğulları Sait (Mert) Prizreni ‘  
12. 08. 1937, Kosovo



Kebabchi Şaban & Oğulları , Muharrem -  
İbrahim - Abdülkadir Bölükemini,  
Prishtinë, Kosovo



### HOŞMERİM / PEYNİR TATLISI'NIN HİKAYESİ

Çanakkale Savaşları'nda hafif yara almış asker mehmedî, komutanları 3 günlüğüne moral izni olsun diye memleketi M. Kemalpaşa'ya yollarlar. Henüz yeni evlidirler & savaşlardan dolayı yurdumuz kıtlık & yokluk içersindedir. Yeni gelin kocası asker mehmedini görünce telaşlanır çünkü evinde mehmedine yedireceği bir şey kalmamıştır. Evde bulduğu şekeri, komşulardan topladığı peyniri, yağı, sütü & irmiği alıp alele acele karıştırıp sıcak sığacağına sofrada kocasının önüne sunar. Kocasının halinden hoşlandığını anlayan gelin kız kocasının etrafında fırıl fırıl dolaşarak sevinçten “hoş mu erim?, hoş mu erim?” diye sorar. Bu tatlı komşularınca da çok beğenilir. Zamanla Hoş mu erim? olur. Hoşmerim.

Hoşmerim Balıkesir' in Havran ilçesinde 500 yılı aşkın bir süredir farklı bir usulle hazırlanan sarı renkli bir tatlıdır.

Evliya Çelebi (1611 – 1682 ), "Seyahatname"sinde bu tatlının, Trabzon'a yerleşen ilk Türk göçebelerinde de görüldüğünü, Havran'a da oradan geçtiğini



anlatır.

İlk hoşmerim üretimini Orta Asya'dan göçler yolu ile gelen Anadolu Yörüklerinin yaptığı bilinmektedir ancak bu tatlının isminin 'Peynir Tatlısı' olarak halk arasında bilindiğidir.

Havran'da ise Osmanlının ilk dönemine uzanan bu tatlıya "Hoşmerim" isminin verilmesi farklı bir hikâyedir. Hoşmerime Osmanlı döneminden gelen bir isim konulmuş. Osmanlı dönemindeki Türk aile yapısında bugünde geçerliliğini kısmen koruyan evli olan kadınlar eşlerine 'Er' veya 'Erim' diye hitap ederdi. Askerden dönen eşine yoksulluk nedeni ile evindeki mutfakta pek bir şey bulamayıp evde bulunan kendi ürettikleri peynir, irmik & şekerden ilk kez yaptığı bir tatlıyı eşine ikram eder & eşinin tepkisini bekler. Bu tatlıyı ilk kez hazırlayıp eşine sunan genç gelinin çekingen & korkmuş bir şekilde eşine "Hoş mu erim?" diye sorar & bu tatlının isminin buradan geldiğine inanılıyor. Günümüze ise bu tatlının adı 'Hoş mu Erim'den zamanla değişikliklere uğrayarak 'Hoşmerim' veya 'Höşmelim' adını alır. Yöre ile özdeşleşen bu hoşmerim tatlısı bu gün artık Havran ilçesinde simgesi olur.

Yukarıda anlatılan yöresel bir hikâye olabilir fakat Farsça Aş - Maram 2'lisinden yani tatlı kaymak 2'lisinden geliyor olması etimolojik olarak daha kuvvetli bir ihtimaldir.

### Rokuefort / Rokfor'un Hikayesi

Rokuefort / Rokfor adında çoban Güney Fransa'daki dağlarda çobanlık yapmış. Aynı yöreden aşık olduğu bir çoban kız varmış. Rokfor çoban yorulduğunda bir mağaranın kuytu kısmına çekilip yemek molası verir. Heybesinden çıkardığı francalı ekmeği ile bir kalıp beyaz peynirini çıkartıp mağara içindeki bir kayanın üzerine peynirini koyar, bir dilim keser, franca ekmeğinden bir parça kopartıp sandwich haline getirir. Tam o sırada mağaranın içinden dışarıdan geçmekte olan sevdiği çoban kızı görür. Telaşından kalıp peynirini unutup francalı sandwich ekmeğini eline alıp çoban kızının peşine düşer. Kendi sürüsü & çoban kızın sürüsü ile beraber kasabaya doğru yol alırlarken sandwich'in yarısını kıza ikram eder, konuşa konuşa kasabaya ilerlerler. Günlerden bir gün Rokfor çoban yine güzergahı olan dağlarda sürüsünü otlamaya çıkar, karnı acıkır, yemek molası vermek için yine aynı mağara yönüne doğru yol alır, heybesine elini attığında peynirin olmadığını yalnız ekmeğin kaldığını fark eder. Aklına o mağara gelir. Hemen mağaraya doğru yol alır. Mağaranın içine girdiğinde nemli kaya üzerindeki kalıp peynirin küflendiğini fark eder, ama karnı da çok açılmıştır. Bıçağı ile 1 dilim kesip ekmeğin arasına koyar. Sandwich'ini ısıtıp tattığında peynirden gelen nefis koku ile tattan büyük haz duyar. Kafasından şimşekler çakar, beyaz kalıp peyniri sarıp hemen kasabanın yolunu tutarlar. Bu kalıp peyniri birkaç dilime kesip yağlı ambalaj kağıdı ile özenle paketleyip kasabadaki & civar köyle kasabalara gıda ürünü satan dükkanlara numune olarak bırakır. Bu peyniri ben dışarıdan özel getiriyorum beğenirseniz bana sipariş verebilirsiniz der & bu peynir çok beğenilip gel zaman git zaman yüklü siparişler alır. Rokfor çoban da o nemli



mağarada kaya üzerinde bu peyniri imal edip ününü Dünya'ya yayar & çok zengin olur.Ah bizdende Van'dan da bir çoban Sülo 'da çıksa.Van'daki Yörsan'ın ünlü otlu peynirini Dünya'ya tanıtırsa ne iyi olurdu ! değil mi?

### **Rokfor Peyniri**

Roquefort peyniri ya da Rokfor peyniri Güney Fransa'nın Roquefort kasabasında üretilmeye başlayan içi küflü, güzel kokulu bir peynirdir. Rokfor'un yapımında Roquefort kasabası civarındaki doğal mağaraların & sonradan bu mağaralara benzetilerek yapılan mahzenlerin olduğu kadar, Rokfor küfünün de büyük etkisi vardır, Rokfor küfö, 2/3'ü buğday unu, 1/3'ü çavdar unu olan bir hamurla hazırlanır. Peynirler mahzenlerde 2 veya 3 ay kalır. İyi bir Rokfor peyniri kavuniçi renginde, ince kabuklu, içi beyaz küf damarlı olan, tereyağı yumuşaklığında & tadındadır. Rokfor peyniri diğere peynirlere oranla dayanıklı bir peynirdir.

### **Van Otlu Peyniri Yapımı**

Van'ın geleneksel otlu peyniri ilkbaharda, hem sütün hem de otun bol olduğu dönemde, genellikle koyun sütünden üretilir. Ancak, koyun sütüne inek & keçi sütü de karıştırıldığı olur. Sütler çiğ olarak ya da çok az ısıtılarak mayalanır. Mayalama sıcaklığı yaklaşık 30 derecedir. Süt 1-2 saatte pıhtılaşır. Daha sonra bir kat pıhtı, bir kat önceden doğranıp hazırlanmış çeşitli yabani otlar olmak üzere bez bir torbaya alınır. Torbaya aktarım işlemi bittiğinde torbanın ağzı kapatılır & 2 taş arasına sıkıştırılarak ya da üstüne tahtadan ağırlık konarak süzölmeye bırakılır. Süzölme 5-6 saat sürer. Elde edilen teleme, ya "kelle" olarak bırakılır ya da tezgah üstünde el büyüklüğünde, yaklaşık 2-3 cm. kalınlığında dilimlere bölünür. daha sonra kuru şekilde tuzlanır veya salamuraya atılır. Pampışikle yenilir.

Salamura tuzlama usulü:

Salamura tuzlama usulünde, peynir dilimleri salamura suyunda bir süre bekletilir & sonra teneke veya plastik kaplara yerleştirilir. Bu kaplar serin bir yerde muhafaza edilerek sonbahara kadar olgunlaşmaya bırakılır.

Kuru tuzlama usulü:

Dilimler üzerine göz kararı kalın mutfak tuzu serpilir, 3-4 gün beklemeye bırakılır. Dilimler daha sonra bol tuz ile yıkanır. Bir kat peynir, bir kat cacık olacak biçimde toprak küplere ya da plastik kaplara yerleştirilir. İşin püf noktalarından biri de peynirlerin kaplara geçirilirken, hiç boşluk kalmayacak şekilde iyice yerleştirilmelidir. Doldurma işi tamamlandıktan sonra sıra kapların ağzına üzüm yaprağı konması & çamurla sıvanmasına gelir. Kaplar serin bir yere kabın ağzı toprağa gelecek şekilde konur & üzeri gevşek bir toprakla ya da kumla örtülür. Peynirler, 2-3 ay dinlenmeye bırakılır.



## ÖRNEK / SAMPLE MENU

Bu kılavuzun içindeki bilgilerin eksiksiz olmasına özen gösterilmiştir.  
The information in this guide is intended to be full & correct.



### art./code nr.: LUNCH & DINNER MENU



- 01 - SET MENU / TABL D'HÔTE (3 ÇEŞİT) \_\_\_\_\_  
02 - ÇORBALAR / SOUPS \_\_\_\_\_  
03 - ETLİ YEMEK / MAIN COURSE \_\_\_\_\_  
04 - SOĞUK MEZELER - ZEYTİN YAĞLILAR / COLD MEZE 'S WITH OLIVEOIL \_\_\_\_\_  
05 - KARIŞIK SALATA / SEASONEL MIXED SALAD / ÇOBAN SALATA \_\_\_\_\_  
06 - CEZAR SALATA / CEZAR SALAD - EXTRA \_\_\_\_\_  
07 - YOĞURT / YOGHURT \_\_\_\_\_  
08 - CACIK / CACIKI "cucumber with yoghurt" \_\_\_\_\_  
09 - TATLILAR / SWEETS / DESSERTS \_\_\_\_\_

#### IZGARALAR / BARBECUE GRILLS

- 10 - İSKENDER / ( porsiyon /portion ) \_\_\_\_\_  
11 - ATOM SANDWICH DÖNER / SANDWICH DONER \_\_\_\_\_  
12 - DÜRÜM DÖNER \_\_\_\_\_  
13 - RODOP KÖFTE / RODOP MEATBALLS / KEBAB ( porsiyon / portion ) \_\_\_\_\_  
14 - KASAP KÖFTE / BUTCHER MEATBALLS ( porsiyon / portion ) \_\_\_\_\_  
15 - PİDELİ KÖFTE / ( porsiyon / portion ) \_\_\_\_\_  
16 - 1/2 EKMEK ARASI KÖFTE / SANDWICH MEATBALLS \_\_\_\_\_  
17 - PİLİÇ ŞİŞ KEBAP / ( porsiyon / portion ) CHICKEN SHISH KEBAB \_\_\_\_\_

#### APERATİFLER / STARTERS

- 18 - KAHVALTI / BREAKFAST \_\_\_\_\_  
19 - SOĞUK SANDWICH / (kaşar peynirli - with kashar cheese ) \_\_\_\_\_  
20 - SOĞUK SANDWICH / sausage , with kashar cheese ( salamlı , kaşar peynirli ) \_\_\_\_\_  
21 - TOAST / with kashar cheese \_\_\_\_\_  
22 - KARIŞIK TOAST / sausage , salami with kaşar cheese \_\_\_\_\_  
23 - PİDELİ TOAST / Barantico special / kaşarlı , salamlı , sucuklu ( döner pidesi ) \_\_\_\_\_  
24 - HAMBURGER \_\_\_\_\_  
25 - PATATES / POMMES - FRITES / CHIPS \_\_\_\_\_

#### SICAK İÇECEKLER / HOT DRINKS

- 26 - ÇAY / TEA \_\_\_\_\_  
27 - FİNCAN ÇAY / LARGE TEA \_\_\_\_\_  
28 - MEYVELİ ÇAY ' lar / FRUIT TEA ' s \_\_\_\_\_  
29 - TÜRK KAHVESİ / TURKISH COFFEE / MOCCA \_\_\_\_\_  
30 - NESCAFÉ \_\_\_\_\_  
31 - ESPRESSO \_\_\_\_\_  
32 - CAPPUCINO \_\_\_\_\_  
33 - SIÇAK ÇİKOLATA / HOT CHOCOLATE \_\_\_\_\_  
34 - SAHLEP \_\_\_\_\_

#### SOĞUK İÇECEKLER / SOFT DRINKS

- 35 - MEŞRUBATLAR / SOFT DRINKS \_\_\_\_\_  
36 - MADEN SUYU / MINERAL WATER \_\_\_\_\_  
37 - MEYVELİ SODA / MINERAL WATER WITH JUICE \_\_\_\_\_  
38 - ENERGY DRINK \_\_\_\_\_  
39 - AYRAN / YOGHURT DRINK \_\_\_\_\_  
40 - SU / WATER / WASSER / küçük, small \_\_\_\_\_  
41 - SU / WATER / WASSER / büyük, large \_\_\_\_\_

**SERVİS İÇİN, LÜTFEN ZİL' E 3 DEFA BASINIZ !**  
**FOR SERVICE, PLEASE PRESS THE BELL 3 TIMES !**  
**FÜR DEN SERVICE, BITTE KLINGELN SIE 3 MAL !**



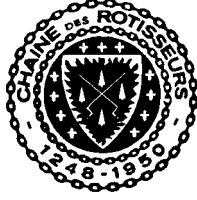

**master menu guide / menu führer / menu rehberi**  
**INTERNATIONAL KITCHEN / KÜCHE / MUTFAK-LEXICON**

*Bu bölüm 3 dilde menu - à la carte hazırlanırken, turizmci meslekdaşlarımıza katkı sağlaması adına, uzun bir zaman içerisinde, eksiksiz & hatasız çalışılmaya özen gösterilerek gerçekleştirilmiştir!*

*Hayırlı işler dileriz. Bu menu rehberinin içindeki bilgilerin eksiksiz olmasına özen gösterilmiştir.*

The information in this menu guide is intended to be full & correct.



English



Deutsch



Française

SAUCES / SOSLAR (GB.)	SAUCEN (GER.)	SAUCES(F.)
Ailloli sauce (garlic mayonnaise)	Aioli-Sauce (mayonnaise mit Knoblauch)	Sauce aioli (mayonnaise au coulis d ail)
American sauce (tomato sauce with lobster butter)	Amerikanische Sauce (Tomatensauce mit Hummerbutter)	américaine (sauce tomate et beurre de homard)
Apple sauce	Apfelmus	aux pommes
Béarnaise sauce (Hollandaise sauce with tarragon)	Béarnier Sauce (Holländische Sauce mit Estragon)	béarnaise (sauce hollandaise à l'estragon)
Béchamel sauce	Béchamelsauce	Béchamel
Bercy sauce (butter, shallots, white wine)	Bercy-Sauce (Butter, Schalotten, Weißwein)	Bercy (beurre, échalotes, vin blanc)
Bordelaise sauce (red wine sauce with beef marrow)	Bordelaise-Sauce (Rotweinsauce mit Rindermark)	bordelaise (sauce au vin rouge avec moelle de bœuf)
Brown sauce	Braune Sauce	brune espanole au pain
Bread sauce	Brotsauce	bourguignonne (sauce au vin rouge)
Butter sauce	Buttersauce	au beurre
Mushroom sauce	Champignonsauce	aux champignons
Chateaubriandsauce (meat glaze enriched with butter & parsley)	Chateaubriand-Sauce (Fleischglace, Butter, Petersilie)	Chateaubriand (glace de viande beurrée et persillée)
Sauce chaud-froid (white sauce with jelly)	Chaufroid-Sauce (Velouté-Sauce mit Gellee)	chaud-froid (velouté à la gelée)
Choron sauce (Béarnaise sauce blended with tomato purée)	Choron-Sauce (Béarnier Sauce mit Tomatenpüree vermischt)	Sauce Choron (sauce béarnaise tomate)
Colbert sauce (maître d'hôtel butter blended with meat glaze)	Colbert-Sauce (Kräuterbutter mit Fleischglace vermischt)	Colbert (beurre maître d'hotel additionné de glace de viande)





SAUCES / SOSLAR (GB.)	SAUCEN (GER.)	SAUCES(F.)
Cumberland sauce (redcurrant jelly, shreds of orange & lemon rind, & mustard)	Colbert-Sauce (Kräuterbutter mit Fleischglace vermischt)	Colbert (beurre maître d'hotel additionné de glace de viande)
Curry sauce	Currysauce	au curry
Dill sauce	Dillsauce	à l'aneth
Egg sauce	Eiersauce	aux œufs
Sauce financière (Madeira sauce flavoured with truffle)	Finanzmannsauce (Madeirasauce mit Trüffel Fond)	financière (sauce madère à l'essence de truffes)
SAUCES / SOSLAR (GB.)	SAUCEN (GER.)	SAUCES(F.)
Shrimp sauce	Garnelensauce	aux crevettes
Genevoise sauce (fish-stock, red wine, anchovy essence)	Genfer Sauce (Fischfond, Rotwein, Sardellenessenz)	genevoise (fumet de poisson, vin rouge, essence d'anchois)
Sauce grand-veneur (a: poivrade sauce with hare-blood; b: poivrade sauce with redcurrant jelly)	Grand-veneur Sauce (a: pfeffersauce mit Hasenblut; b: Pfeffersauce mit Johannisbeergelee)	grand-veneur (a: sauce poivrade liée au sang de lièvre; b: sauce poivrade et gelée de groseilles)
Gribiche sauce (tartare sauce with mustard) Green mayonnaise (with purée of herbs)	Gribiche-Sauce / Tatarensauce mit Senf Grüne Mayonnaise (mit Kräuterpüree)	gribiche (sauce tartare à la moutarde) Sauce verte (mayonnaise à la purée d'herbes)
Green mayonnaise (with purée of herbs)	Grüne Mayonnaise (mit Kräuterpüree)	Sauce verte (mayonnaise à la purée d'herbes)
Vinaigrette sauce	Grüne Sauce	vinaigrette
Hollandaise sauce (yolks of egg, melted butter, lemon juice)	Holländische Sauce (Eigelb, geschmolzene Butter, Zitronensaft)	hollandaise, Isigny (émulsion de beurre et de jaunes d'œufs)
Curry sauce	Indische Sauce	à l'indienne
Sauce chasseur (mushrooms, white wine, tomato sauce)	Jägersauce (Champignons, Weißwein, Tomatensauce)	chasseur (champignons, vin blanc, sauce tomate)
Redcurrant sauce	Johannisbeersauce	aux groseilles (rouges)



SAUCES / SOSLAR (GB.)	SAUCEN (GER.)	SAUCES(F.)
Joinville sauce (white wine sauce with shrimp butter)	Joinville-Sauce (Weißweinsauce mit Garnelenbutter)	Joinville (sauce vin blanc avec beurre de crevettes)
Caper sauce	Kapernsauce	aux câpres
Cardinal sauce (béchamel & lobster butter)	Kardinals-Sauce (Béchamel & Hummerbutter)	cardinal (Béchamel et beurre de homard)
Cheese sauce	Käsesauce	Mornay
Lyonnais sauce (onion sauce)	Lyoner Sauce (Zwiebelsauce)	Lyonnais (sauce aux oignons)
Maderia sauce	Madeirasauce	Madère
Maitre d'hôtel sauce (butter, parsley & lemon juice)	Maitre-Sauce (Butter, Petersilie & Zitronensaft)	maitre d'hotel (beurre, persil et jus de citron)
Maltese sauce (Hollandaise sauce with juice of blood oranges)	Malteser Sauce (holländische Sauce mit Saft von Blutorangen)	maltaise (sauce hollandaise au jus d'oranges sanguines)
Marrow sauce	Marksauce	moelle
Matelote sauce	Matrosensauce	Sauce marinière
Mayonnaise	Mayonnaise	mayonnasie
Horseradish sauce	Meerrettichsauce	raifort
Mint sauce	Minzsauce	menthe
Mornay sauce, cheese sauce	Mornay-Sauce (Béchamel mit geriebenem Käse)	Mornay (Béchamel au fromage)
Mousseline sauce (Hollandaise sauce with whipped cream)	Mousseline-Sauce (holländische Sauce mit geschlagener Sahne)	mousseline (sauce hollandaise additionnée de crème fouettée)
Nantua sauce (béchamel with crayfish butter)	Nantua-Sauce (Béchamel mit Krebsbutter)	Nantua (Béchamel et beurre d'écrevisses)
Nantua sauce (béchamel with crayfish butter)	Nantua-Sauce (Béchamel mit Krebsbutter)	Nantua (Béchamel et beurre d'écrevisses)
Sauce normande (white wine sauce with fishstock)	Normannische Sauce (Weißweinsauce mit Fischfond)	normande (sauce vin blanc au fumet de poisson)
Orange sauce	Orangensauce	à l'orange
Paprika sauce	Paprikasauce	au paprika
Truffle sauce	Périgueux-Sauce	Périgueux (aux truffes)

SAUCES / SOSLAR (GB.)	SAUCEN (GER.)	SAUCES(F.)
Parsley sauce	Petersiliensauce	persil
Poivrade sauce (with vinegar & pepper)	Pfeffersauce (mit Essig & Pfefferkörnern)	poivrade (avec vinaigre et poivre)
Piquant sauce (with vinegar, gherkins, parsley & chervil)	Pikante Sauce (mit Essig, Petersilie, Essiggurken & Kerbel)	piquante (avec vinaigre, cornichons, persil et cerfeuil)
Port wine sauce	Porweinsauce	au porto
Cranberry sauce	Porweinsauce	aux airelles
Cream sauce	Rahmsauce	à la crème
Ravigote sauce (oil & vinegar with chopped capers, parsley & hard boiled egg)	Ravigote-Sauce (Essig & Öl mit Kapern, Petersilie, hartgekochtem Ei)	ravigote (hulle et vinaigre avec câpres, persil et ceuf dur hachés)
Rémoulade sauce (mayonnaise with mustard, gherkins & capers)	Remouladensauce (Mayonnaise mit Senf, Kapern, Essiggurken)	Sauce rémoulade (mayonnaise avec moutarde, câpres et cornichons)
Robert sauce (onion, white wine, mustard)	Robert-Sauce (Zwiebel, Weißwein, Senf)	Robert (oignon, vin blanc, moutarde)
Red wine sauce	Rotweinsauce	vin rouge
Cream sauce	Sahnesauce	à l crème
Anchovy sauce	Sardellensauce	aux anchois
Smitane sauce, sour cream souce	Saure Rahmsauce	smitane (avec crème aigre)
Turtle sauce Maderia sauce with essence of herbs	Schildkrötensauce (Madeirasauce mit Auszug von Kräutern)	tortue (sauce madère avec infusion d'herbs)
Chive sauce	Schildkrötensauce	à la ciboulette
Mustard sauce	Senfsauce	moutarde
Soubise sauce (onion purée with béchamel)	Soubise-Sauce (Zwiebelpüree mit Béchamel)	Soubise (ou coulis d'oignons)
Sauce suprême (chicken-stock with cream)	Suprême-Sauce (Geflügel-Rahmsauce)	suprême (velouté de volaille à la crème)
Tartare sauce (mayonnaise of hard-boiled eggs with chives, gherkins & capers)	Tatarensauce (Mayonnaise aus hartgekochtem Eigelb mit Kapern & Schnittlauch)	tartare (mayonnaise aux jaunes d'œufs durs avec câpres, cornichons, ciboulettes)



SAUCES / SOSLAR (GB.)	SAUCEN (GER.)	SAUCES(F.)
Deviled sauce (demiglace, white wine or vinegar, cayenne)	Teufelssauce (Demiglace, Weißwein oder Essig, Cayennepfeffer)	diabole (demi-glace, vin blanc ou vinaigre, poivre de Cayenne)
Tomato sauce	Tomatensauce	tomate
Truffle sauce	Trüffelsauce	Sauce Périgueux
Venetian sauce (white wine sauce with purée of herbs)	Venezianische Sauce (Weißweinsauce mit Kräuterpüree)	vénitienne (sauce vin blanc avec purée d'herbes)
Villeroi sauce (white sauce with essence of mushrooms)	Villeroi-Sauce (weiße Sauce mit Champignonfond)	Villeroi (sauce allemande à l'essence de champignons)
Juniper sauce	Wacholdersauce	au genièvre
White sauce	Weiße Sauce	blanche
White wine sauce	Weißweinsauce	au vin blanc
Zingara sauce (tomatoed demi-glace with strips of ham, ox-tongue, mushrooms, truffles)	Zigeuner-Sauce (Demiglace mit Einlage von Champignons, Zunge & Schinken)	zingara (demi-glace tomatee avec julienne de jambon, langue, champignons, truffes)
Lemon sauce	Zitronensauce	au citron
BUTTERS / TEREYAĞLILAR (GB.)	BUTTERMISCHUNGEN (GER.)	BEURRES COMPOS'ES(F.)
Brown butter	Braune Butter	Beurre noisette
Colbert butter (maitre d'hôtel butter mixed with meat-glaze & chopped tarragon)	Colbert-Butter (Kräuterbutter mit Fleischglaze & gehacktem Estragon vermischt)	Colbert (beurre maitre d'hôtel additionné de glace de viande et d'estragon haché)
Shrimp butter	Garnelenbutter Krevettenbutter	de crevettes
Lobster butter	Hummerbutter	de homard
Caviar butter	Kaviarbuter	de caviar
Maitre d'hôtel butter (with chopped parsley & lemon juice)	Kräuterbutter (Butter mit gehackter Petersilie & Zitronensaft)	maitre d'hôtel (beurre avec persil haché et jus de citron)
Crayfish butter	Krebsbutter	d'écrevisses
Salmon butter	Lachsbutter Maitre-Butter s. Kräuterbutter	de saumon fumé

<b>BUTTERS / TEREYAĞLILAR (GB.)</b>	<b>BUTTERMISCHUNGEN (GER.)</b>	<b>BEURRES COMPOS'ES(F.)</b>
Brown butter	Nußbutter	noisette
Anchovy butter	Sardellenbutter	d'anchois
Snail butter (butter mixed with shallots, garlic & parsley)	Sardellenbutter Scheckenbutter (Butter mit schalotten, Knoblauch und Petersilie)	pour escargots (beurre pétri avec écholates, ail persil)
Black butter	Schwarze Butter	noir
Mustard butter	Senfbutter	de moutarde
Truffle butter	Trüffelbutter	de truffes
Melted butter	Zerlassene Butter	fondue

<b>HORS-D'ŒUVRES (GB.) ORDÖVR</b>	<b>VORSPEISEN (GER.)</b>	<b>HORS-D'ŒUVRE (F.)</b>
Eel in Jelly	Aal in Gelee	Anguille à la gelée
Marinated artichokes	Artischocken, griechisch (marinierte Artischn.)	Artichauts à la grecque (artichauts marinés)
Cold meats, cold cuts	Aufschnitt	Charcuterie assortie
Oysters	Austern	Huîtres
Oyster cocktail	Austern-Cocktail	Cocktail d'huîtres
Oyster patties	Austern-Pastetchen	Bouchées aux huîtres
Oyster boats	Austern-Schiffchen	Barquettes d'huîtres
Bear's ham	Bärenschinken	Jambon d'ours
Pickled herring	Bismarck-Hering	Hareng mariné
Vol-au-vent	Blätterteigpastete	Vol-au-vent
à la financière (with chicken dumplings, cocks' combs & kernels)	à la financière (mit ragoût fin gefüllt)	à la financière (garni quenelles, crêtes et rognons de coq, olives)
Blinis (small buck-wheat pancakes)	Blini (Hefepflinsen mit Buchweizenzusatz)	Blinis (petites crêpes au sarrasin)
Botargo (pressed caviar made of mullet roe)	Botarga (Preßkaviar aus Meeräscherogen)	Boutargue (sorte de caviar d'œufs de mullet)
	Bouchées s. Pastetchen	
Bloater, red herring	Bückling	Hareng saur, hareng fumé
Grisons air-dried beef	Bündner Fleisch	Vlande séchée des Grisons
Canapés	Canapés	Canapés
Caviar canapés	Kaviar Canapés	au caviar
Anchovy canapés	Sardellen Canapés	aux anchois
Mushrooms on toast	Champignons auf Toast	Croûte aux champignons



<b>HORS-D'ŒUVRES (GB.) ORDÖVR</b>	<b>VORSPEISEN (GER.)</b>	<b>HORS-D'ŒUVRE (F.)</b>
Chester-straws	Chesterstangen	Paillettes au chester
Gherkins	Cornichons	Cornichons (au vinaigre)
Cold eggs mayonnaise	Eier kalt mit Mayonnaise	Œufs durs mayonnaise
Cold eggs tartare sauce	kalt mit Tatarensauce	Œufs à la tartare
Gherkins	Essiggurken	Cornichons (au vinaigre)
Scalloped fish	Fisch in Muschelschalen	Coquilles de poisson
Fish salad	Fischsalat	Salade de poisson
Hors-d'œuvres of fish	Fisch-Vorspeisen	Hors-d'œuvre de poissons
Meatless hors-d'œuvres	Fleischlose Vorspeisen	Hors-d'œuvre de maigres
Swiss fondue	Fondue (Käsefondue)	Fondue savoyarde
Smoked trout	Forelle, geräuchert	Truite fumée
Frankfurters	Frankfurter Würstchen	Saucisses de Francfort
Fruit cocktail, fruit cup	Früchtecocktail	Cocktail de fruits
Goose-liver mousse	Gänseleber-Mousse	Mousse de foie gras
Parfait de foie gras	Gänseleber-Parfait	Parfait de foie gras
Pâté de foie gras	Gänseleber-Pastete	Pâté de foie gras
Shrimps	Garnelen	Crevettes (grises)
Shrimp cocktail	Garnelen-Cocktail	Cocktail de crevettes
Shrimp salad	Garnelen-Salat	Salade de crevettes
Chicken croquettes	Geflügelkroketten	Croquettes de volaille
Scalloped chicken	Geflügel in Muschelschalen	Coquilles de volaille
Iced grape-fruit	Grapefruit, eisgekühlt	Grape-fruit frappé
Herring tillets	Heringsfilets	Filets de hareng
Herring salad	Heringsalat	Salade de hareng
Lobster cocktail	Hummer-Cocktail	Cocktail de homard
Lobster mayonnaise	Hummer-Mayonnaise	Mayonnaise de homard
Lobster salad	Hummer-Salat	Salade de homard
Lobster boats	Hummer-Schiffchen	Barquettes de homard
Sweetbread vol-au-vent	Kalbsmilch-Pastete	Vol-au-vent de ris de veau
Cold meats, cold cuts	Kalte Platte	Viandes froides
Cheese soufflé	Käse-Auflauf	Soufflé au fromage
Cheese-straws	Käsestangen	Allumettes au fromage
Ramekins (cheese tartlets)	Käsetörtchen	Ramequins



Caviar, caviare	Kaviar	Caviar
Caviar canapés	Kaviarbrötchen	Canapés au caviar
Lapwing eggs	Kiebitzeier	Œufs de vanneau
Patties à la reine	Königin-Pastetchen	Bouchées à la reine
Shrimps	Krabben (Krevetten)	Crevettes (grises)
Crayfish cocktail	Krebsschwanz-Cocktail	Cocktail d'écrevisses
Croquettes	Kroketten	Croquettes
Salmon mayonnaise	Lachs-Mayonnaise	Mayonnaise de saumon
Marinated tenches	Marinierte Schleien	Escabèche de tanches
Seafood	Meeresfrüchte	Fruits de mer
Iced melon	Melone, eisgekühlt	Melon frappé
Mixed pickles	Mixed Pickles	Mixed pickles
Mortadella	Mortadella	Mortadelle (de Bologne)
Ox-muzzle salad	Ochsenmaulsalat	Museau de bœuf en salade
Green olives	Oliven (grüne)	Olives vertes
Ripe olives, black olives	Oliven (schwarze)	Olives noires
Sardines in oil	Ölsardinen	Sardines à l'huile
Parma ham	Parmaschinken	Jambon de Parme
Parmesan en brochette	Parmesanspießchen	Atteraux au parmesan
Patties, bouchées	Pastetchen	Bouchées
Oyster patties	Austern-Pastetchen	aux huîtres
Bouchées à la reine	Königin-Pastetchen	à la reine
Pickled onions	Perlzwiebeln	Petits oignons (au vinaigre)
Salt ox-tongue	Pökelszunge	Langue écarlate
Pressed caviar	Preßkaviar	Caviar pressé
Quiche Lorraine (tart with bacon & cream)	Quiche lorraine (Lothringer Specktorte)	Quiche lorraine (tarte à la crème et au lard)
Radishes	Radieschen	Radis (roses)
Shells à la financière	Ragoût fin in Muscheln	Coquilles à la financière
Ramekins (cheese tartlets)	Ramequins (Käsetörtchen)	Ramequins
Smoked eel	Räucheraal	Anquille fumée
Red herring, bloater	Räucherhering	Hareng saur
Smoked salmon	Räucherlachs	Saumon fumé
Smoked beef	Rauchfleisch	Bœuf fumé
Roebuck ham	Rehschinken	Jambon de chevreuil

Radish	Rettich	Radis (blanc ou noir)
Rissoles (fried cakes with meat or fish stuffing)	Rissolen (gebackene halbmondförmige Pasteten mit Füllung)	Rissoles (chaussons farcis, frits à grande friture)
with truffles	mit Trüffeln	aux truffes
Rollmops (rolled herring)	Rollmops	Rollmops
Russian eggs (set on Russian salad)	Russische Eier (mit russischem Salat)	Œufs à la russe (dressés sur salade russe)
Salami	Salami	Salami
Hungarian salami	ungarische	Salami hongrois
Sandwich	Sandwich (belegtes Brot)	Sandwich
Cheese sandwich	Käsebrot	au fromage
Ham sandwich	Schinkenbrot	au jambon
Anchovy canapés	Sardellenbrötchen	Canapés aux anchois
Anchovy butter	Sardellenbutter	Beurre d'anchois
Anchovy fillets	Sardellenfilets	Filets d'anchois
Anchovy straws	Sardellenstäbchen	Allumettes aux anchois
Scampi cocktail	Scampi-Cocktail	Cocktail de langoustines
Ham	Schinken	Jambon
Boiled ham	gekochter	cuit
Smoked ham	geräucherter	fumé
Raw ham	roher	cru
Westphalian ham	westfälischer	de Westphalie
Ham mousse	Schinken-Mousse	Mousse de jambon
Ham cornets, ham rolls	Schinken-Röllchen	Cornets de jambon
Snails	Schnecken	Escargots
Swedish platter (marinated & smoked fish specialities)	Swedenplatte (marinierte & geräucherte Fischspezialitäten)	Plat suédois (spécialités de poissons marinés et fumés)
Pickled onions	Silberzwiebeln	Petits oignons
Bacon	Speck (geräucherter)	Bacon, lard fumé
Smoked eel	Spickaal	Anguille fumée
Smoked goose-breast	Spickgans	Poitrine d'oie fumée
Tomato salad	Tomatensalat	Tomates à la vinaigrette
tunny in oil	Thunfisch in Öl	Thon à l'huile



Variety of canapés	Verschiedene Canapés	Canapés divers
Quail's eggs	Wachteleier	Œufs de caille
Welsh rabbit (dish of melted cheese on toast)	Welsh Rabbit (Röstbrot mit heißem Käse belegt)	Welsh rabbit (fromage fondu sur toast)
Game pie, venison pie	Wildpastete	Pâté de gibier
Sausage	Wurst	Saucisson
Assorted sausages	Wurstplatte	Assiette de charcuterie

<b>SOUPS / ÇORBALAR (GB.)</b>	<b>SUPPEN (GER.)</b>	<b>POTAGES (F.)</b>
Eel soup	Aalsuppe	Potage à l'anguille
Bagration soup (cream of veal soup with macaroni)	Bagration-Suppe (Kalbfleischnuppe mit Makkaroni-Einlage)	Bagration (velouté de veau garni de tronçons de macaroni)
Country style soup (vegetable soup)	Bauern-Suppe (Gemüsesuppe)	à la paysanne (potage aux légumes)
Beer soup	Biersuppe	Soupe à la bière
Du Barry soup (cauliflower cream-soup)	Blumenkohlsuppe	Crème Du Barry, crème de chou-fleur
Condé soup (purée of red beans)	Bohnensuppe (rote)	Potage Condé (purée de haricots rouges)
Haricot soup	Bohnensuppe (weiße)	Faubonne (purée de haricots blancs)
Bouillabaisse (French fish-soup with saffron)	Bouillabaisse (Fischnuppe mit Safran)	Bouillabaisse (soupe de poisson safranée)
Broth, bouillon, beeftea	Bouillon	Bouillon
Bouillon with egg	mit Ei	à l'œuf
Garnished bouillon	mit Einlage	garni
Busecca (tripe & bean soup)	Busecca (Kuttelnuppe mit weißen Bohnen)	Busecca (gras-double de veau et haricots)
Carmen soup (cream of rice coloured with tomato purée)	Carmen-Suppe (passierte Reissuppe mit Tomatenmark gefärbt)	Velouté Carmen (velouté à la crème de riz tomate)
Cream of mushroom soup	Champignoncremesuppe	Crème de champignons
Cream-soup	Consommé s. Krafbühe	Potage crème
Darblay soup	Darblay-Suppe	Potage Darblay



SOUPS / ÇORBALAR (GB.)	SUPPEN (GER.)	POTAGES (F.)
(potato purée with shredded vegetables)	(Kartoffelsuppe mit Gemüsestreifen)	(purée Parmentier avec julienne)
Double consommé	Doppelte Kraftbrühe	Consommé double
Cream of green pea soup	Erbsenpüreesuppe	Crème de petits pois
Pheasant consommé	Fasanen-Kraftbrühe	Consommé de faisan
Lenten soup, soup maigre	Fastensuppe	Potage maigre
Fish-soup	Fischsuppe	Soupe de poisson
Broth, bouillon, beeftea	Fleischbrühe	Bouillon
Bouillon with egg	mit Ei	à l'œuf
Consommé Célestine (with shredded pancake)	Frittatensuppe	Consommé Célestine (garni crêpe taillée en julienne)
Spring vegetable soup	Frühlingsuppe	Consommé printanier
Gazpacho (soup of uncooked vegetables with vinegar & oil)	Gazpacho (kalte Suppe aus rohem Gemüse mit Öl & Essig)	Gaspacho (potage non cuit de légumes frais avec huile et vinaigre)
Cream of chicken soup	Geflügelcremesuppe, Hühner Sappa	Crème de volaille
Vegetable broth	Gemüsebrühe	Bouillon de légumes
Cream of vegetable soup	Gemüsecremesuppe	Crème de légumes
Vegetable soup, julienne	Gemüsesuppe	Potage aux légumes
Germiny soup (consommé with shredded sorrel, bound with egg-yolks & cream)	Germiny-Suppe (Bouillon mit Sauerampfer, stark mit Eigelb & Sahne legiert)	Germiny (consommé avec chiffonnade d'oseille et double liaison de crème et œufs)
Cream of barley soup	Gerstenschleimsuppe	Crème d'orge
Barley soup	Gerstensuppe	Potage à l'orge
Santé soup (potato purée with sorrel)	Gesundheitssuppe (Kartoffelsuppe mit Sauerampfer)	Potage de santé (purée Parmentier à l'oseille)
Semolina dumpling soup	Grießnockerlsuppe	Potage aux quenelles de semoule
Semolina soup	Grießsuppe	à la semoule
Goulash soup (highly seasoned soup of beef & potatoes)	Gulaschsuppe	au goulash (potage très relevé avec dés de bœuf)
Oatmeal soup	Haferschleimsuppe	Crème d'avoine / de requin



<b>SOUPS / ÇORBALAR (GB.)</b>	<b>SUPPEN (GER.)</b>	<b>POTAGES (F.)</b>
Shark's fin soup	Haifischflossensuppe	Consommé aux nageoires
Cream of brain soup	Hirnsuppe	Crème de cervelle
Chickenbroth	Hühnerbrühe	Consommé de volaille
Lobster soup	Hummercremesuppe	Bisque de homard
Game soup	Jägersuppe	Potage chasseur
Julienne, vegetable soup	Juliennesuppe	Potage julienne
Calf's tail soup	Kalbsschanksuppe	Potage queue de veau
Cold consommé	Kalte Kraftbrühe	Consommé froid
Kangaroo-tail soup	Känguruhschwanzsuppe	Potage queue de kangourou

<b>SOUPS / ÇORBALAR (GB.)</b>	<b>SUPPEN (GER.)</b>	<b>POTAGES (F.)</b>
Cream of carrot soup	Karottensuppe	Potage Crécy
Potato soup	Kartoffelsuppe	Potage Parmentier
Chervil soup	Kerbelsuppe	Potage au cerfeuil
Clear soup	Klare Suppe	Potage clair
Tyrolean dumpling soup	Knödelsuppe (Speck-)	Potage aux boulettes au lard
Cabbage soup	Kohlsuppe	Soupe aux choux
Cream of chicken soup	Königinsuppe	Potage à la reine
Consommé, clear soup	Kraftbrühe	Consommé
with profiteroles	mit Backerbsen	aux profiteroles
Célestine (with shredded pancake)	Cèlestine (mit Pfannkuchenstreifen)	Célestine (garni crêpe taillée en julienne)
Royal soup (with diced custard)	Kraftbrühe mit Eierstich	Consommé royal (garni dés de royale)
Consommé with pasta or rice	mit Einlage	garni
Vermicelli soup	mit Fadennudeln	au vermicelle
Consommé with liver quenelles	mit Lebernockern	aux noques de foie
madrilène (tomatoed chickenbroth)	Madrilène (mit Tomatenpüree)	Madrilène (consommé de volaille tomate)
with beef marrow	mit Mark	à la moelle
with marrow quenelles	mit Markklößchen	aux quenelles à la moelle
Clear rice soup	mit Reiseinlage	Potage au riz



SOUPS / ÇORBALAR (GB.)	SUPPEN (GER.)	POTAGES (F.)
Consommé in cup	in der Tasse	Consommé en tasse
with pasta	mit Teigwaren	Potage aux pâtes
Crayfish cream-soup	Krebssuppe	Bisque d'écrevisses
Cress soup	Kressesuppe	Potage au cresson
Pumpkin soup	Kürbissuppe	Soupe au potiron
Cream of leek soup	Lauchcremesuppe	Crème de poireaux
Liver dumpling soup	Leberknödelsuppe	Potage aux boulettes de foie
Riced liver soup (liver mixture put through a ricer into boiled broth)	Leberreissuppe	au foie à la viennoise (consommé garni de petites nouilles de foie)
Lentil soup	Linsensuppe	Potage Conti (ou Esaü)
Londonderry soup (consommé flavoured with Madeira, garnished w. diced calf's head)	Londonderry-Kraftbrühe (mit Madeira & Einlage von Kalbskopf in Würfeln)	Potage Londonderry (consommé au madère, garni tête de veau en dés)
Consommé with milt croûtons	Milzschnittensuppe	Potage aux croûtons de rate
Minestrone (thick vegetable soup garnished with rice or macaroni)	Minestrone (dicke Gemüsesuppe mit Reis- oder Teigwaren-Einlage)	Minestrone (potage aux légumes de saison, garni riz ou pâtes)
Mulligatawny (soup) (chicken soup flavoured with curry)	Mulligatawny-Suppe (Currysuppe mit Huhn)	Potage mulligatawny (Soupe de poulet au curry)
Mussel soup	Muschelsuppe	Soupe aux moules
Consommé with quenelles	Nockerlsuppe	Potage aux quenelles
Noodle soup	Nudelsuppe	Potage aux pâtes
Noodle soup	Nudelsuppe (Eier-)	Potage aux nouilles
Noodle soup with chicken	mit Huhn	Poule au pot aux nouilles
Oxtail soup	Ochsenschwanzsuppe (Oxtailsuppe)	Oxtail, potage queue de bœuf



<b>SOUPS / ÇORBALAR (GB.)</b>	<b>SUPPEN (GER.)</b>	<b>POTAGES (F.)</b>
Portuguese soup (tomato soup)	Portugiesische Suppe (Tomatensuppe)	Potage à la portugaise (purée de tomates)
Pot-au-feu (broth with meat & vegetables)	Potaufeu (Eintopf aus Fleisch, Brühe & Gemüse)	pot-au-feu, petite marmite
Princess soup (cream of chicken soup with asparagus tips)	Prinzessin-Suppe (Geflügelcremesuppe mit Spargelspitzen)	Crème princesse (crème de volaille garnie de pointes d'asperges)
Ravioli soup	Ravioli-Suppe	Potage aux ravioli
Cream of rice soup	Reisschleimsuppe	Crème de riz
Clear rice soup	Reissuppe (klare)	Potage au riz
Broth, bouillon, beeftea	Rindsuppe	Bouillon
Rice & pea soup	Risi-Pisi (Risibisi)	Potage de riz aux petits pois
Velvet soup (carrot purée with tapioca)	Samtsuppe (Karottenpüree mit Tapioka)	Potage velours (purée Crécy avec tapioca)
Sorrel soup	Sauerampfersuppe	Potage à l'oseille
Real turtle soup	Schildkrötensuppe	Potage tortue
Mock-turtle soup	falsche	Potage fausse tortue
Turtle soup Lady Curzon (flavoured with curry & covered with whipped cream)	Lady Curzon (mit Curry Gewürzt & mit überbräunter Schlagsahne bedeckt)	Potage tortue Lady Curzon (relevé au curry et couvert de crème fouettée)
Snail soup	Schneckensuppe	Potage aux escargots
Mutton broth (garnished with pearl-barley)	Schottische Kraftbrühe (Hammelbouillon)	Consommée écossais (bouillon de mouton)
Bird's nest soup	Schwalbennestersuppe	Potage aux nids d'hirondelles
Cream of celery soup	Selleriesuppe	Crème de céleri
Cream fo asparagus soup	Spargelcremesuppe	Crème Argenteuil
Cream of spinach soup	Spinatcremesuppe	Crème d'épinards
Today's soup, soup du jour	Tagessuppe	Potage au jour
Tapioca soup	Tapiokasuppe	Potage au tapioca
Tomato soup	Tomatensuppe	Potage aux tomates
Cold wine soup	Wein-Kaltschale	Potage froid au vin

<b>SOUPS / ÇORBALAR (GB.)</b>	<b>SUPPEN (GER.)</b>	<b>POTAGES (F.)</b>
Game soup	Wildsuppe	Potage de gibier
tripe soup, işkembe çorbası	Kuttelnsuppe	
Zuppa pavese (beefbroth with slices of fried bread & an egg poached in it)	Zuppa pavese (Bouillon mit gerösteten Brotscheiben, darauf ein pochiertes Ei)	Zuppa pavese (consommé avec tranches de pain grillé et un œuf cassé dessus)
Onion soup	Zwiebelsuppe	Soupe à l'oignon
Baked onion soup	überbacken	Soupe gratinée
<b>EGGS / YUMURTALAR (GB.)</b>	<b>EIERSPEISEN (GER.)</b>	<b>ŒUFS (F.)</b>
Fried eggs with bacon	Eier auf amerikanische Art (Spiegeleier mit Speck)	Œufs frits à l'américaine (au bacon)
Poached eggs Benedict (a: cream of salt cod, cream sauce, b: slice of tongue, hollandaise sauce)	nach Benediktiner Art (verlorene: a: Stockfischmus, Rahmsauce; b: Zungenscheibe, holländische Sauce)	pochés benédictine (a: brandade de morue, sauce crème; b: tranche de langue, sauce hollandaise)
Fried eggs Bercy (with grilled sausage & tomato sauce)	Bercy (Spiegeleier mit Bratwürstchen & Tomatensauce)	sur le plat Bercy (garnis d'une saucisse grillée, sauce tomate)
Scrambled eggs with mushrooms	mit Champignons (Rühreier)	brouillés aux champignons
Stuffed eggs Chimay (eggs au gratin with mushroom stuffing)	Chimay (gefüllte: überbackene Eier mit Champignonfülle)	farcis Chimay (œufs durs gratinés, farcis de champignons)
Eggs en cocotte	in Cocotte	en cocotte
Poached eggs Florentine (eggs on bed of leafspinach)	florentinisch (verlorene: gratinierte Eier auf Blattspinat)	pochés à la florentine (œufs gratinés sur lit d'épinards)
Jellied eggs	in Gelee	à la gelée
Cold eggs with mayonnaise	mit Mayonnaise	durs à la mayonnaise

EGGS / YUMURTALAR (GB.)	EIERSPEISEN (GER.)	ŒUFS (F.)
Fried eggs Meyerbeer (with grilled lamb's kidney & truffle sauce)	Meyerbeer (Setzeier mit gegrillter Lammniere & Trüffelsauce)	sur le plat Meyerbeer (avec rognon grillé et sauce Périgueux)
Poached eggs au gratin	Mornay (verlorene Eier gratiniert)	Mornay (œufs pochés au gratin)
Poached eggs d'Orsay (on toast, coated with sauce Chateaubriand)	d'Orsay (verlorene: auf Toast, mit Chateaubriandsauce)	pochés d'Orsay (sur toast, nappés de sauce Chateaubriand)
Creamed eggs en cocotte	Eier in Rahm	Œufs en cocotte à la crème
Ham & eggs	Mit Schinken (Setzeier)	poêlés au jambon
Scrambled eggs with asparagus	mit Spargeln (Rühreier)	brouillés Argenteuil (aux asperges)
Bacon & eggs	mit Speck (Setzeier)	poêlés au bacon
Cold eggs tartare sauce	mit Tatarensauce	froids à la tartare
Poached eggs on toast	auf Toast (pochierte)	pochés sur toast
Scrambled eggs with tomatoes	mit Tomaten (Rühreier)	brouillés portugaise (aux tomates)
Fried eggs Turbigo (with sausage)	Turbigo (Spiegeleier mit Bratwürstchen)	sur le plat Turbigo (avec saucisse)
Fried eggs with chickenlivers "turkish"	türkisch (Spiegeleier mit Geflügelleber)	au plat à la turque (aux folies de volaille)
Omelette	Eierkuchen	Omelette plate
Fried eggs (in deep fat)	Gebackene Eier	Œufs frits
Stuffed eggs	Gefüllte Eier	farcis
Poached eggs au gratin	Gratinierte Eier	Mornay
Hard-boiled eggs	Hartgekochte Eier	durs
Poached eggs	Pochierte Eier	pochés
Scrambled eggs	Rühreier	brouillés
Fried eggs	Spiegeleier (Setzeier)	sur le plat, poêlés,
		au miroir
Poached eggs	Verlorene Eier	pochés
Soft-boiled eggs	Weiche Eier (2-3 Min.)	à la coque
Medium-boiled eggs	Weiche Eier (5-6 Min.)	mollets
Omelette, omelet	Omelette	Omelette
Artichoke omelette	mit Artischocken	aux fonds d'artichauts



<b>EGGS / YUMURTALAR (GB.)</b>	<b>EIERSPEISEN (GER.)</b>	<b>ŒUFS (F.)</b>
Peasant's omelette	Omelette nach Bauernart (mit Speckwürfeln, Kartoffeln & Sauerampfer; nicht gerollt)	Omelette à la paysanne (omelette plate avec lardons, pommes de terre et oseille)
Mushroom omelette	mit Champignons	aux champignons
		à la forestière (aux morilles ou cèpes)
Chicken-liver omelette	mit Geflügelleber	aux foies de volaille
Potato omelette	mit Kartoffeln	Parmentier
Cheese omelette	mit Käse	au fromage
Savoury omelette	mit Kräutern	aux fines herbes
Plain omelette	natur	nature
Kidney omelette	mit Nieren	aux rognons
Mushroom omelette	mit Pilzen	aux champignons
Savoy omelette (cheese & potato omelette; not folded)	auf savoyische Art (mit Kartoffeln & Käse; nicht gerollt)	à la savoyarde (omelette plate avec gruyère et pommes)
Ham omelette	mit Schinken	au jambon
Spanish omelette (flat omelette with onion, pimiento & tomato)	auf spanische Art (mit Tomaten & Paprika; nicht gerollt)	à l'espagnole (omelette plate avec tomates, oignons et poivrons)
Asparagus omelette	mit Spargelspitzen	aux pointes d'asperges
Bacon omelet	mit Speck	au lard
Florentine omelette,	mit Spinat	à la florentine (aux épinards)
Spinach omelette		
Tomato omelette	mit tomaten	à la portugaise
Onion omelette	mit Zwiebeln	à la Lyonnaise





<b>FISH &amp; SHELL-FISH / BALIKLAR (GB.)</b>	<b>FISCHE &amp; SCHALTIERE (GER.)</b>	<b>POISSONS ET CRUSTACÉS (F.)</b>
Eel	Aal	Anguille
Eel in dill sauce	in Dillsauce	à l'aneth
Fried eel	gebacken	frite
Smoked eel	geräuchert	furnée
Matelote of eel (eel stew)	auf Matrosenart	en matelote
Eel on the spit	vom Spieß	à la broche
Burbot, eel-pout (kaya balığı)	Aalquappe (max.50 cm.)	Lotte (d'eau douce)
Allice shad, alose	Alse	Alose
	Angler s. Seeteufel	
Grayling	Äsche	Ombre
Oysters	Austern	Huîtres
Fried oysters	gebacken	frites
Oysters au gratin	gratiniert	au gratin, Mornay
River trout, brown trout	Bachforelle	Truite de rivière
Brook-trout, speckled trout	Bachsäibling	Ombre, saumon de fon- taine
Barbel	Barbe	Barbeau
Perch	Barsch (Fluß-)	Perche
Perch au bleu	blau	au bleu
Lake whitefish	Blaufischen	Corégone
Piddocks	Bohrmuscheln	Pholades
Bream	Brachse (Brasse)	Brème
Chub	Döbel	Chevaine, chevesne
	Dorade s. Goldmakrele	
Spiny dogfish	Dornhai	Aiguillat
Greater weever	Drachenfisch	Vive
Whitefish	Felchen	Corégone
Fried fish fillet	Fischfilet, gebacken	Fillet de poisson frit
Mixed fried fish	Fischfritüre	Friture de poissons
Fish mayonnaise	Fischmayonnaise	Mayonnaise de poisson

FISH & SHELL-FISH / BALIKLAR (GB.)	FISCHE & SCHALTIERE (GER.)	POISSONS ET CRUSTACÉS (F.)
Flounder (Benekli pisi balığı)	Flunder (max.50 cm.)	Flet
	Fogosch s. Zander	
Trout	Forelle	Truite
Trout au bleu	blau	au bleu
Fried trout	gebacken	frite
Trout meuniere	gebraten (in Butter)	au beurre, meunière
Stuffed trout	gefüllt	farcie
Trout in jelly	in Gelee	à le gelée
Trout amandine	mit Mandeln	aux amandes
Trout meunière	nach Müllerinart	à la meunière
Trout in red wine	in Rotwein	au vin rouge
Smoked filets of trout	Forellenfilets, geräuchert	Filets de truite fumés
Frog's legs	Froschschenkel	Grenouilles
Fried frog's legs	gebacken	frites
Frog's legs sauté	gebraten (in Butter)	sautées
Shrimps	Garnelen (Sandgarnelen)	Crevettes grises
Curried shrimps	in Currysauce	Crevettes au curry
Prawns	(Felsen-, Stein-)	Crevettes roses, bouquet
Prawns	(Geißel-)	Crevettes
Brill (deniz pisi)	Glatthead (max.75 cm.)	Barbue
Smooth dogfish	Glatthai	Émissole
Rosefish, bergylt (Lipsos, adabey)	Goldbarsch (max. 1 metre)	Sébaste, rascasse de fond, chèvre
Fried rosefish fillet	Goldbarschfilet, gebacken	Filet de sébaste frit
Gilt head	Goldbrasse	Daurade, dorade royale
Dorado, dolphin	Goldmakrele	Coriphène
Gudgeons	Gründlinge	Goujons
Smoked haddock	Haddock (geräucherter Schellfisch)	Haddock (aiglefin fumé)
Pike	Hecht	Brochet
Roast pike	gebraten	Brochet rôti
Pike-perch	Hechtbarsch	Sandre



<b>FISH &amp; SHELL-FISH / BALIKLAR (GB.)</b>	<b>FISCHE &amp; SCHALTIERE (GER.)</b>	<b>POISSONS ET CRUSTACÉS (F.)</b>
	Hechtdorsch s. Seehecht	
Pike balls	Hechtklößchen	Quenelles de brochet
Halibut	Heilbutt	Flétan
Broiled halibut	vom Rost	Flétan grillé
Herring (tirsi balığı)	Hering (max. 40 cm)	Hareng
Marinated herring	mariniert	mariné
Porbeagle (köpek balığı)	Heringshai (Kalbfisch)	Lamie, taupe (max.350 cm)
Dory, John Dory (dülger, peygamber balığı)	Heringskönig (max. 60 cm.)	Saint-Pierre, dorée
<b>FISH &amp; SHELL-FISH / BALIKLAR (GB.)</b>	<b>FISCHE &amp; SCHALTIERE (GER.)</b>	<b>POISSONS ET CRUSTACÉS (F.)</b>
Cockles	Herzmuscheln	Coques, bucardes
Squills, mantis shrimps	Heuschreckenkrebs	Squilles
Garfish, needlefish (zargana)	Hornhecht (max.80 cm.)	Orphie, aiguille de mer
Huchen, huch	Huchen	Huchon
Lobster	Hummer	Homard
Lobster, American style (in rich tomato sauce)	auf Amerikanische Art (in tomatensauce)	à l'américaine (sauté aux tomates)
Lobster in aspic	in Aspik	Aspic de homard
Lobster flambé	flambiert	Homard flambé
Lobster thermidor (lob- ster meat baked in lob- ster shell)	Thermidor (Hummerfleisch in der Schale überbacken)	Homard thermidor (escalop- pes gratinées dans la cara- pace)
Lobster mayonnaise	Hummer-Mayonnaise	Mayonnaise de homard
Scallops, escallops	Jakobmuscheln	Coquilles Saint-Jacques
Cod, codfish	Kabeljau	Cabillaud
Fried cod	gebacken	frit
Cold cod with mayon- naise	mit Mayonnaise	froid mayonnaise
Boiled cod parsley sauce	mit Petersiliensauce	sauce persil
	Kaisergranat s. Scampi	
Calamaries, squids	Kalmare	Calmars, encornets



FISH & SHELL-FISH / BALIKLAR (GB.)	FISCHE & SCHALTIERE (GER.)	POISSONS ET CRUSTACÉS (F.)
Fried calamaries	gebacken	Friture de calmars
Scallops, fan shells	Kammuscheln	Pétoncles, peignes
Crucian	Karausche	Carassin
Carp	Karpfen	Carpe
in beer sauce	in Bier	à la bière
au bleu	blau	au bleu
Miller's thumbs, bull- heads	Kaulköpfe (Groppen)	Chabots
Dab (pisi balığı, dere)	Kliesche (max.40 cm.)	Limande
Gurnard, gurnet	Knurrhahn	Grondin
Coal-fish	Köhler (Kohlfisch)	Lieu noir, charbonnier
	Krabben s. Garnelen	
Octopus, poulp(e)	Krake	Poulpe, pieuvre
Crayfish	Krebse (Flußkrebse)	Écrevisses
Swimming crayfish (served in their broth)	in der Brühe	à la nage (servies dans leur cuisson)
Crayfish pyramid	Krebspyramide	en buisson
Salmon (somon)	Lachs	Saumon
Boiled salmon	gekocht	au court-bouillon
Broiled salmon steak	vom Rost	grillé
Salmon trout, sea trout	Lachsforelle	Truite saumonée, truite de mer
Salmon cutlet	Lachskotelett	Côtelette de saumon
Salmon medallion	Lachsmedaillon	Médaillon de saumon
Spiny lobster, crawfish	Languste	Langouste
Spiny lobster en bellevue (lobster meat in jelly)	Bellevue (Schwanzscheiben in Gelee)	à la parisienne (escalopes à le gelée)
Crawfish with mayon- naise	mit Mayonnaise	à la mayonnaise
Spiny lobster medallions	Langustenmedaillons	Médaillons de langouste
Ling	Leng	Lingue
Wrasse	Lippfisch	Vieille, labre
Alice shad, alose	Maifisch	Alose



FISH & SHELL-FISH / BALIKLAR (GB.)	FISCHE & SCHALTIERE (GER.)	POISSONS ET CRUSTACÉS (F.)
Mackerel (Uskumru)	Makrele (max.50 cm.)	Maquereau
en papillote	en Papillote	en popillote
with brown butter	mit schwarzer Butter	au beurre noir
Whitefish	Maräne	Marène, corégone
Conger, conger eel (miğir)	Meeraal (max 300 cm.)	Congre (siyah olani)
Grey mullet (kefal)	Meeräsche (max.90 cm.)	Mulet, muge
Broiled grey mullet	gegrillt	Mulet grillé
Red mullet (Barbunya)	Meerbarbe (max.40 cm.)	Rouget, rouget barbet
Red mullet en papillote	en Papillote	Rouget en papillote
Grilled red mullet	vom Rost	Rouget grillé
Surmullet, red mullet	(Streifenbarbe)	Rouget de roche, surmulet
Sea-bream, Am. porgy	Meerbrasse	Pagel, pageot
Date-shells	Meerdatteln	Dattes de mer
Seafood	Meeresfrüchte	Fruits de mer
	Meerforelle s. Lachsforelle	
Goby	Meergrundel	Gobie
Spider-crabs	Meerspinnen	Araignées de mer
Whiting	Merlan	merlan
Fried whiting	gebacken	frit
Whiting in white wine	in Weißwein	au vin blanc
Razor shells	Messermuscheln	Couteaux
Mussels	Miesmuscheln	Moules
au gratin	gratiniert	au gratin
à la marinière (in white wine)	nach Matrosenart (in Weißwein)	à la marinière (au vin blanc)
Moray	Muräne	Murène
Lamprey	Neunauge (Lamprete)	Lamproie
Scallops, fan shells	Pektenmuscheln	Pétoncles, peignes
Greater weever	Petermännchen	Vive
Dory, John Dory (trago- nya)	Peterfisch (max.40 cm.)	Saint-Pierre, dorée (çarpan)
Anchovy ( Hamsi)	Sardelle	anchois



FISH & SHELL-FISH / BALIKLAR (GB.)	FISCHE & SCHALTIERE (GER.)	POISSONS ET CRUSTACÉS (F.)
Scallops, escallops	Pilgermuscheln	Coquilles Saint-Jacques
Roach	Plötze (Routauge)	Gardon
Rainbow trout	Regenbogenforelle	Truite arc-en-ciel
Whitefish	Renke	Corégone
Rhine salmon	Rheinsalm	Saumon du Rhin
Skate, ray	Rochen	Raie
Boiled skate caper sauce	mit Kapernsauce	sauce aux câpres
Skate with black butter	mit schwarzer Butter Rotbarbe s. Meerbarbe	au beurre noir
	Rotbarsch s. Goldbarsch	
Red sea-bream	Rotbrasse	Pagel, pageot
Whitefish	Sandfelchen	Féra
Anchovies (hamsi)	Sardellen (max.15 cm.)	Anchois
Pilchards, sardines (sardalya)	Sardinen (max.25 cm.)	Sardines
Dublin (Bay) prawns, scampi, Norway lobsters	Scampi	Langoustines, scampi
Curried scampi	mit Curry	Langoustines au curry
Fried Dublin Bay prawns	gebacken	Langoustines frites
Razor shells, razor clams	Scheidenmuscheln	Couteaux
(Fresh) haddock	Schellfisch	Aiglefin, églefin
Turtle	Schildkröte	Tortue
	Schill s. Zander	
Tench	Schleie	Tanche
au bleu	blau	au bleu
au gratin	überbacken	gratinée
Loach	Schmerle (Bartgrundel)	Loche franche
Snails	Schnecken	Escargots
Plaice	Scholle	Plie, carrelet
Swordfish (kılıç balığı)	Schwertfisch (max.5 m.)	Espadon
	Seebarsch s. Wolfbarsch	
Lake-trout	Seeforelle	Truite de lac
Grilled lake-trout	vom Grill	Truite de lacs grillée

FISH & SHELL-FISH / BALIKLAR (GB.)	FISCHE & SCHALTIERE (GER.)	POISSONS ET CRUSTACÉS (F.)
Hake	Seehecht	Colin, merlu
Hake meunière	in Butter gebraten	Colin meunière
Boiled hake	gekocht	Colin poché
Fillets of hake	Seehechfilets	Filets de colin
Sea-urchins	Seeigel	Oursins, châtaignes de mer
	Seelachs s. Köhler	
Octopus	Seepolyp	Pieuvre, poulpe
Rockling	Seequappe	Motelle, loche de mer
Char, charr	Seesaibling	Ombles chevalier
Angler-fish (fener balıǵı)	Seeteufel (max.170 cm.)	Lotte (de mer), boudroie
Broiled angler-fish	vom Rost	Lotte, grillée
Sole (dil balıǵı)	Seezunge (max.60 cm.)	Sole
Sole Colbert (breaded, fried, filled with parsley butter)	Colbert (paniert, gebacken & mit Kräuterbutter gefüllt)	Colbert (panée, frite, four- rée de beurre maître d'hô- tel)
Fried sole	gebacken	frite
Grilled sole	gegrillt	grillée
Sole au gratin	gratiniert	au gratin
Sole Mornay	Mornay	Mornay (au gratin)
Sole meunière	nach Müllerinart	à la meunière (au beurre)
Fillets of sole	Seezungenfilets	Filets de sole
of sole Orly (deep-fried, served with tomato sauce)	Orly (gebäcken & mit Tomatensauce angerichtet)	de sole Orly (filets frits ser- vis avec sauce tomate)
Fillets of sole in white wine	Seezungenfilets in Weißwein	Filets de sole au vin blanc
Rolled sole fillets	Seezungenröllchen	Paupiettes de sole
Bleaks	Silberfische	Ablettes
Fried bleaks	gebäcken	Friture d'ablettes
Mirror carp	Spiegelkarpfen	Carpe miroir
Sprats	Sprotten	Sprats
Smoked sprats	(Kieler)	Saprats fumés de Kiel
Turbot (kalkan)	Steinbutt (max.100 cm.)	Turbot

Boiled turbot sauce hollandaise	gekocht mit holländischer Sauce	poché sauce hollandaise
Braised turbot	geschmort	braisé
Grilled turbot	vom Rost	grillé
Turbot in white wine	in Weißwein	au vin blanc
Date-sheels	Steindatteln	Dattes de mer
Sterlet	Sterlet	Sterlet
Smelt	Stint	Éperlan
Smelts en brochette	Stint-Spießchen	Éperlans en brochette
Salt cod, stockfish	Stockfisch	Morue
Salt cod in cream	in Rahmsauce	à la crème
Salt cod in tomato sauce	in Tomatensauce	sautée aux tomates
Brandade of salt cod (purée of salt cod)	Stockfisch-Brandade (Stockfischpüree)	Brandade de morue (purée de morue)
Sturgeon	Stör	Esturgeon
Broiled sturgeon steak	Störschnitte vom Rost	Darne d'esturgeon grillée
Shore crabs, green crabs	Strandkrabben	Crabes
Surmullet, red mullet	Streifenbarbe	Rouget de roche, surmulet
Crab	Taschenkrebs	Tourteau

<b>FISH &amp; SHELL-FISH / BALIKLAR (GB.)</b>	<b>FISCHE &amp; SCHALTIERE (GER.)</b>	<b>POISSONS ET CRUSTACÉS (F.)</b>
Tuna (-fish), tunny (ton balığı)	Thunfisch (max.300 cm.)	Thon
Braised tuna with mushrooms	Thunfisch gedünstet mit Champignons	Thon braisé aux champignons
Broiled tuna-fish	vom Rost	grillé
Cuttlefish	Tintenfische	Seiches
Burbot, eel-pout	Trüsche	Lotte (d'eau douce)
Bleaks	Ukeleie	Ablettes
Fried bleaks	gebacken	Friture d'ablettes
Bar	Umber	Ombrine
Clams, carpet shells	Venusmuscheln	Clovisses, palourdes
Venus clams	(warzige)	Praires
Whitebaits	Weißfische	Blanchailles
Fried whitebaits	gebacken	Friture de blanchailles



<b>FISH &amp; SHELL-FISH / BALIKLAR (GB.)</b>	<b>FISCHE &amp; SCHALTIERE (GER.)</b>	<b>POISSONS ET CRUSTACÉS (F.)</b>
	Weissling s. Merlan	
Sheat-fish	Wels (Waller)	Glane, silure glane
Bass (levrek)	Wolfbarsch (max.100 cm.)	Bar, loup (de mer)
Boiled bass	gekocht	Bar au court-bouillon
Cold bass with mayonnaise	mit Mayonnaise	Bar froid mayonnaise
Bass meunière	nach Müllerinart	Bar meunière, bar au beurre
Grilled bass	vom Rost	Bar grillé
Dentex	Zahnbrasse	Denté
Pike-perch	Zander	Sandre
Pike-perch au bleu	blau	au bleu
Stuffed pike-perch	gefüllt	farcié
Broiled pike-perch	vom Rost	grillée
Pike-perch au gratin	überbacken	au gratin
Pike-perch fillets	Zanderfilets	Filets de sandre
Trout from the fish-tank	Zuchtforellen	Traites d'élevage
<b>MEAT DISHES (GB.)</b>	<b>FLEISCHGERICHTE (GER.)</b>	<b>PLATS DE VIANDE (F.)</b>
Mutton	Hammelfleisch	Mouton
Veal	Kalbfleisch	Veau
Lamb	Lammfleisch	Agneau
Spring lamb, baby lamb	Milchlamm	Agneau de lait
Beef	Rindfleisch	Bœuf
Mutton	Schöpsenfleisch	Mouton
Pork	Schweinfleisch	Porc
Sucking-pig	Spanferkel	Cochon de lait, porcelet
Beefsteak, steak	Beefsteak	Bifteck, steak
Beefsteak with a fried egg	mit Setzei	à cheval (avec un œuf au plat dessus)
Lamb pluck	Beuschel von Lamm	Fressure d'agneau
Bitoke (kind of Hamburg steak)	Bitok (russisches Hacksteak)	Bitoke (beefsteak haché, sauté au beurre)



MEAT DISHES (GB.)	FLEISCHGERICHTE (GER.)	PLATS DE VIANDE (F.)
Black pudding	Blutwurst	Boudin noir
Grilled sausages	Bratwürste vom Grill	Saucisses grillées
Meatballs, meat croquettes	Buletten	Fricadelles, boulettes
Chateaubriand (double thick fillet steak)	Chateaubriand (doppelt dickes Filetsteak)	Chateaubriand (ou châteaubriant)
Escalope of veal Cordon bleu (two slices of veal with ham & cheese between)	Cordon bleu (zwei dünne, innen mit Käse & Schinken belegte Kalsschnitzel)	Escalope de veau Cordon bleu (escalope double panée, farcie de jambon et fromage)
Hamburger (fried cake of minced beef)	Deutsches Beefsteak (Hamburger)	Hamburger (bifteck haché de forme ronde)
Double sirloin steak	Doppeltes Entrecote	Entrecôte double
Fricasseeed veal	Eingemachtes Kalbfleisch	Blanquette de veau
Hot pot, hotchpotch	Eintopf	Potée
Knuckle of pork (salted)	Eisbein	Jarret de porc (salé)
of pork with sauerkraut	mit Sauerkraut	de porc à la choucroute
Sirloin steak, entrecôte	Entrecote	Entrecôte
Grilled sirloin steak with parsley butter	vom Grill mit Kräuterbutter	grillée maître d'hôtel
Sirloin steak with cress	mit Kresse	vert-pré (au cresson)
Sirloin steak lyonnaise (with fried onions)	nach Lyoner Art (mit Zwiebeln)	à la Lyonnaise (aux oignons)
Minute sirloin steak	minute	minute
Sirloin steak lyonnaise (with fried onions)	Mirabeau (mit Sardellenfilets & Oliven)	Mirabeau (garnie filets d'anchois et olives)
Tyrolean sirloin steak (with tomatoes & fried onion rings)	nach Tiroler Art (mit Tomaten & Zwiebelringen garniert)	tyrolienne (garnie tomates et rondelles d'oignons frits)
Sirloin steak in red wine sauce	nach Weinhändlerart (in Rotweinsauce)	marchand de vin (au vin rouge)

<b>MEAT DISHES (GB.)</b>	<b>FLEISCHGERICHTE (GER.)</b>	<b>PLATS DE VIANDE (F.)</b>
Beef Stroganov (beef stew in sour cream)	Filetgulasch Stroganow (in sauer Sahne)	Sauté de bœuf Stroganov (à la crème aigre)
Fillet steak	Filetsteak	Filet grillé
Flemish stew (slices of beef stewed in beer)	Flämische Karbonaden (Rinderschnitzel in Bier geschmort)	Carbonnades à la flamande (tranches de bœuf
<b>MEAT DISHES (GB.)</b>	<b>FLEISCHGERICHTE (GER.)</b>	<b>PLATS DE VIANDE (F.)</b>
Charcoal-broiled meats	Fleisch vomHolzkohlengrill	Grillades au feu de bois
Fondue bourguignonne	Fleischfondue	Fondue bourguignonne
Meatballs	Fleischklöße	Boulettes, fricadelles
Frankfurters	Frankfurter Würstchen	Saucisses de Francfort
Meatballs, meat croquettes	Frikadellen	Fricadelles, boulettes
Boiled beef	Gekochtes Rindfleisch	Bœuf bouilli
Chipped veal in cream	Geschnetzeltes (Kalbfleisch in Rahm)	Émincé de veau zurichoise
Grenadines (braised larded slices of veal)	Grenadins (gespickte Kalbsschnitzel)	Grenadins de veau (escalopes piquées)
Grilled meats, grills	Grilladen	Grillades
Grilled steak	Grill-Steak	Steak grillé
Hungarian goulash	Gulasch, ungarisch	Goulash à la hongroise
Meatloaf	Hackbraten	Pain de bœuf
Hamburger (or Hamburg steak)	Hamburger (Frikadelle, Hacksteak)	Hamburger
Roast mutton	Hammelbraten	Rôti de mouton
Leg of mutton, gigot	Hammelkeule	Gigot de mouton
Roast leg of mutton with onions & potatoes	nach Bäckerinart (mit Kartoffeln & Zwiebeln im Backofen gebraten)	de mouton boulangère (rôti avec pommes de terre et oignons)
Irish stew (mutton stew with onion & potato)	Irish Stew (Eintopf aus Hammelfleisch)	Irish stew (ragoût de mouton)
Escalope of veal chasseur	Jäger-Schnitzel	Escalope de veau chasseur
Galantine of veal	Kalbfleischgalantine	Galantine de veau
Veal pie	Kalbfleischpastete	Pâté de veau
Roast veal	Kalbsbraten	Rôti de veau



MEAT DISHES (GB.)	FLEISCHGERICHTE (GER.)	PLATS DE VIANDE (F.)
Cold roast veal	kalt	Rôti de veau froid
Calf's sweetbreads	Kalbsbries	Ris de veau
sweetbreads with mushrooms	mit Champignons	de veau aux champignons
Sweetbreads with peas	mit Erbsen	de veau Clamart
Stuffed breast of veal	Kalbsbrust, gefüllt	Poitrine de veau farcie
Calf's gristle	Kalbsbrustknorpel	Tendrons de veau
Braised calf's gristle	geschmort	de veau braisés
Fillet of veal	Kalbsfilet	Filet de veau
Larded fillet of veal	gespickt	Filet de veau piqué
Veal balls	Kalbsfrikadellen	Fricadelles de veau
Fricandeau of veal	Kalbs-Fricandeau	Fricandeau de veau
Fricassee of veal	Kalbs-Frikassee	Fricassée de veau
Fried calf's feet	Kalbsfüße, gebacken	Pieds de veau frits
Grilled calf's feet	vom Rost	Pieds de veau grillés
Veal goulash	Kalbsgulasch	Goulash de veau
Knuckie of veal	Kalbshaxe	Jarret de veau
Grilled calf's heart	Kalbsherz vom Rost	Cœur re veau grillé
Calf's brains (pl)	Kalbshirn	Cervelle de veau
Fried calf's brains	gebacken	Cervelle frite
Brains fried in butter	gebraten	de veau meunière
Brains with black butter	mit schwarzer Butter	Cervelle au beurre noir
Leg of veal	Kalbskeule	Cuisseau de veau
Calf's head	Kalbskopf	Tête de veau
Fried calf's head	gebacken	de veau frite
Calf's head vinaigrette sauce	Kalbskopf in grüner Sauce	Tête de veau à la vinaigrette
Calf's head en tortue (garnished with olives, mushrooms, gherkins)	auf Schildkrötenart (mit Oliven, Champignons, Essiggurken)	de veau en tortue (garnie olives, champignons, cornichons)
Veal cutlet	Kalbskotelett	Côte de veau
Jellied veal cutlet	Bellevue (in Gelee)	de veau en bellevue (en gelée)
Veal cutlet Milanese (breaded cutlet)	nach Mailänder Art (paniertes Kotelett)	de veau milanaise (côte de veau panée)

<b>MEAT DISHES (GB.)</b>	<b>FLEISCHGERICHTE (GER.)</b>	<b>PLATS DE VIANDE (F.)</b>
Veal cutlet sauté	natur	de veau sauté
Breaded veal cutlet	paniert	de veau panée
Veal cutlet en papillote	en Papillote	de veau en papillote
Veal cutlet Pojarski (minced veal cutlet, fried in butter)	Pojarski (gehacktes Kotelett in Butter gebraten)	de veau Pojarski (côte de veau hachée, sautée au beurre)
Grilled veal cutlet	vom Rost	de veau grillée
Calf's liver	Kalbsleber	Foie de veau
Calf's liver with apples	nach Berliner Art (mit Äpfeln)	à la berlinoise (aux pom- mes fruits)
Calf's liver & bacon	auf englische Art (mit Speckscheiben)	de veau à l'anglaise (sauté au bacon)
<b>MEAT DISHES (GB.)</b>	<b>FLEISCHGERICHTE (GER.)</b>	<b>PLATS DE VIANDE (F.)</b>
Fried calf's liver	gebacken	de veau frit
Calf's liver sauté	gebraten	de veau sauté
Calf's liver en brochette	am Spießchen	Brochettes de foie de veau
Calf's lights (pl)	Kalbslunge	Mou de veau
Medallion of veal	Kalbsmedaillon	Médaillon de veau
of veal with mushrooms	mit Champignons	de veau aux champignons
	Kalbsmilch s. Kalbsbries	
Calf's kidney	Kalbsniere	Rognon de veau
Calf's kidney flambé	flambiert	de veau flambé
Grilled calf's kidney	gegrillt	de veau grillé
Kidney in Madeira sauce	in Madeirasauce	de veau au Madère
Calf's kidney sauté	sautiert	de veau sauté
Calf's kidney Turbigo (gar- nished with mushrooms & sausage)	Turbigo (mit Champignons & Bratwürstchen)	de veau Turbigo (garni de champignons et d'une saucisse)
Calf's kidney in white wine	in Weißweinsauce	de veau au vin blanc
Loin of veal	Kalbsnierenbraten	Longe de veau
Roast loin of veal	Kalbsnuß, gebraten	Noix de veau rôtie
Braised loin of veal	geschmort	de veau braisée
Jellied loin of veal	gesülzt	de veau en gelée



MEAT DISHES (GB.)	FLEISCHGERICHTE (GER.)	PLATS DE VIANDE (F.)
Calf's ears	Kalbsohren	Oreilles de veau
Veal stew	Kalbsragout	Sauté de veau
Veal stew with spring vegetables	auf Frühlingsart (mit jungem Gemüse)	de veau printanier (aux primeurs)
Veal stew, hunter's style (with mushrooms & tomatoes)	nach Jägerart (mit Champignons & Tomaten)	de veau chasseur (aux champignons et tomates)
Veal stew Marengo (with tomatoes & mushrooms)	Marengo (mit Tomaten Champignons & Weißwein)	de veau Marengo (aux tomates et aux champignons)
Veal roulades	Kalbsrouladen	Paupiettes de veau
Saddle of veal	Kalbsrücken	Selle de veau
Saddle of veal chartreuse (with vegetables cooked in moulds)	nach Kartäuser Art (mit Gemüse, in Becherformen gekocht)	de veau à la chartreuse (garnie chartreuse de légumes)
Saddle of veal Orlov (braised sliced saddle browned in hot oven with onion purée)	Kalbsrücken Prinz Orlov (braisiert, in Scheiben geschnitten & mit Zwiebelmus glaciert)	Selle de veau Orlov (braisée, escalopée, glacée au four avec une purée Soubise)
Leg of veal	Kalbsschlegel	Cuisseau de veau
Escalope of veal	Kalbschnitzel	Escalope de veau
Veal escalope chasseur (with mushrooms)	nach Jägerart (mit Champignons)	de veau chasseur (aux champignons)
Escalope of veal sauté	natur	de veau sauté
Breaded escalope of veal	paniert	de veau panée
Creamed escalope of veal	in Rahm	de veau à la crème
Stuffed shoulder of veal	Kalbsschulter, gefüllt	Épaule de veau farcie
Veal steak	Kalbssteak	Steak de veau
Knuckle of veal, shin of veal	Kalbsstelze	Jarret de veau
Calf's tongue	Kalbszunge	Langue de veau
Ragout of tongue	Kalbszungen-Ragout	Langue de veau en ragoût
Tripe	Kaldaunen	Tripes (pl)
Cold meats, cold cuts	Kalte Platte	Viandes froides
Smoked spare-rib	Kasseler (Rippespeer)	Côte de porc fumée
Roast kid	Kitzbraten	Chevreau rôti

MEAT DISHES (GB.)	FLEISCHGERICHTE (GER.)	PLATS DE VIANDE (F.)
Meat-filled cabbage rolls	Kohl-Rouladen	Paupiettes de chou
Meatballs in savoury sauce	Königsberger Klopse	Boulettes de bœuf sauce piquante
Boiled pork with horse-radish	Krenfleisch	Porc bouilli au raifort
Tripe (işkembe)	Kutteln	Tripes (pl)
Roast lamb	Lammbraten	Rôti d'agneau
Lamb's sweetbreads	Lambries	Ris d'agneau
Stuffed breast of lamb	Lammbrust, gefüllt	Poitrine d'agneau farcie
Fricassee of lamb	Lamm-Frikassee	Fricassée d'agneau
Roast leg of lamb	Lammkeule, gebraten	Gigot d'agneau rôti
Lamb cutlet, lamb chop	Lammkotelett	Côtelette d'agneau
Breaded lamb cutlet	gebacken	d'agneau panée
Grilled lamb cutlet	vom Rost	d'agneau grillée
Lamb noisettes	Lammnüsschen	Noisettes d'agneau
Lamb stew	Lammragout	Sauté d'agneau
Lamb stew with spring vegetables	auf Frühlingsart (mit jungem Gemüse)	d'agneau printanier (aux primeurs)
Roast saddle of lamb	Lammrücken, gebraten	Selle d'agneau rôtie
Shoulder of lamb	Lammschulter	Épaule d'agneau
Roast shoulder of lamb with onions & potatoes	nach Bäckerin-Art (mit Kartoffeln im Backofen gebraten)	d'agneau boulangère (cuite au four sur pommes boulangère)
Liverwurst, liver sausage	Leberwurst	Boudin de fole
Roast sirloin (of beef)	Lendenbraten	Aloyau rôti
Tournedos (tenderloin steak)	Lendenschnitte	Tournedos (médaillon de filet de bœuf)
Tournedos, arlésienne (with egg-plant, onions & tomatoes)	auf arlesische Art (mit Eierfrüchten, Zwiebeln, Tomaten)	à l'arlésienne (garni d'aubergines, oignons et tomates)

MEAT DISHES (GB.)	FLEISCHGERICHTE (GER.)	PLATS DE VIANDE (F.)
Tournedos Clamart (with artichoke bottoms filled with peas)	mart (mit erbsengefüllten Artischockenböden)	Clamart (aux fonds d'artichauts remplis de pois)
Tournedos for gourmets (with gooseliver)	nach Feinschmeckerart (mit Gänseleber)	des gourmets (fourré escalope de foie gras)
Grilled tournedos	vom Grill	grillé
Broiled tournedos sauce béarnaise	vom Grill mit Béarner Sauce	béarnaise
Tournedos Henry IV (a: chipped potatoes, sauce béarnaise; b: artichoke bottoms, noisette potatoes)	Lendenschnitte Heinrich IV. (a: Pommes frites, Béarner Sauce; b: Artischockenböden, Nußkartoffeln)	Tournedos Henri IV (a: Pommes Pont-Neuf, sauce béarnaise; b: fonds d'artichauts, pommes noisettes)
Tournedos Helder (with tomatoes & Parisienne potatoes)	Helder (mit Tomaten & Pariser Kartoffeln garniert)	Helder (aux tomates concassées et pommes parisiennes)
in Madeira sauce	in Madeirasauce	sauté au Madère
masquette (with quartered artichokes & potatoes)	Masquette (mit geviertelten Artischocken, Kartoffeln & Trüffeln)	masquette (aux quartiers d'artichauts, pommes et truffes)
Masséna (with artichoke bottoms & marrow. Truffle sauce)	Masséna (mit Artischockenböden & Rindermark)	Masséna (aux fonds d'artichauts et moelle. Sauce Périgueux)
Tournedos Portugues (with tomatoes)	auf portugiesische Art (mit Tomaten)	à la portugaise (aux tomates)
Rossini (with slice of gooseliver & truffles. Madeira sauce)	Rossini (mit Gänseleberscheibe & Trüffeln, Madeirasauce)	Rossini (garni de foie gras et lames de truffes. Sauce madère)
Roast fillet of beef	Lungenbraten	Filet de bœuf rôti
Hash of calf's lighst	Lungen-Haschee	Hachis de mou de veau
Mixed grill	Mixed grill	Mixed grill
Escalope of veal sauté	Naturschnitzel	Escalope de veau sautée
Loin of veal	Nierenbraten (Kalbs-)	Longe de veau
Kidneys en brochette	Nierenspießchen	Rognons en brochettes
Roast beef	Ochsenbraten	Rôti de bœuf
Oxtail	Ochsenchwanz	Queue de bœuf



MEAT DISHES (GB.)	FLEISCHGERICHTE (GER.)	PLATS DE VIANDE (F.)
Ragout of oxtail	Ochsenchwanz-Ragout	de bœuf en ragoût
Ox-tongue	Ochsenzunge	Langue de bœuf
Braised ox-tongue	geschmort	de bœuf braisée
Ox-tongue in Madeira	in Madeira	de bœuf au Madère
Ossobuco (braised section of veal knuckle)	Ossobuco (Kalbshaxe in Scheiben gedünstet)	Osso-buco (rouelle de jarret de veau braisée)
Escalope of veal with paprika	Paprika-Schnitzel	Escalope de veau au paprika
Escalope of veal, Parisienne (dipped in beaten egg & fried)	Pariser Schnitzel (in verquirltes Ei getaucht & gebacken)	Escalope de veau à la parisienne (panée à l'œuf et frite)
Pepper-steak	Pfeffersteak	Steak au poivre
Piccata (slice of veal fried in butter with parsley & lemon)	Piccata (kleines Naturschnitzel mit Petersilie & Zitrone)	Piccata (petite escalope de veau sautée au persil et citron)
Salb ribs of pork	Pökelkarree	Carré de porc salé
salt ox-tongue	Pökelszunge	Langue écarlate
	Rahmschnitzel s. Sahne	
Smoked beef	Rauchfleisch	Bœuf fumé
Smoked ox-tongue	Räucherzunge	Langue de bœuf fumée
Roast beef	Rinderbraten	Rôti de bœuf
Breast of beef	Rinderbrust	Poitrine de bœuf
Fillet of beef, tenderloin	Rinderfilet	Filet de bœuf
Fillet of beef with mixed vegetables	nach Gärtnerin-Art (mit Gemüse)	de bœuf à la jardinière (aux légumes)
Roast fillet of beef	gebraten	de bœuf rôti
Fillet of beef in Madeira	in Madeirasauce	de bœuf au Madère
Fillet of beef Portuguese (with stuffed tomatoes)	auf portugiesische Art (mit Tomaten)	de bœuf portugaise (aux tomates farcies)
Fillet of beef Wellington (baked in pastry)	Rinderfilet Wellington (in Blätterteighülle)	Filet de bœuf Wellington (en croûte de feuilletage)
Beef stew, ragout of beef	Rinderragout	Estouffade (de bœuf)
Beef roulades, beef olives	Rinderrouladen	Paupiettes de bœuf

MEAT DISHES (GB.)	FLEISCHGERICHTE (GER.)	PLATS DE VIANDE (F.)
Burgundy beef stew (stewed in red wine with mushrooms & small onions)	Rindfleisch auf Burgunder Art (in Rotwein mit Zwiebelchen & Champignons geschmort)	Bœuf bourguignon (sauté au vin rouge avec champignons et petits oignons)
Boiled beef	gekocht	
Beef à la mode (braised with carrots, onions & calf's foot)	auf modische Art (mit Karotten & Kalbsfuß geschmort)	
	Rindslende s. Rinderfilet	
Roast sirloin (of beef)	Rippenstück, gebraten	Contrefilet rôti
	Rippespeer s. Kasseler	
Döner kebab, iskender kebab/ tabak iskender/ porsiyon / tabak servisi (Turkish special/Bursa/TUR.)	Döner kebab, iskender kebab / tabak iskender / Drechen spieß grill / portion / Teller service (Türkisch special/Bursa/TUR.)	Döner kebab, iskender kebab / plate service / Shish grill / portion (Turkish special/Bursa/TUR.)
Rodop köftesi / rodop meatballs (Turkish special/Bursa/Tur.)	Rodop köftesi / rodop frikadellen (Turkish special/Bursa/Tur.)	Rodop köftesi / rodop meatballs (Turkish special/Bursa/Tur.)
İnegöl köfte / inegöl meatballs (Turkish special/Bursa/Tur.)	İnegöl köfte / inegöl meatballs (Turkish special/Bursa/Tur.)	İnegöl köfte / inegöl meatballs (Turkish special/Bursa/Tur.)
Pideli köfte / Kayhan-Kayıhan (Turkish special/Bursa/Tur.)(İskender kebabının muadili / an alternative to iskender döner kebab	Pideli köfte / Kayhan-Kayıhan (Turkish special/Bursa/Tur.)(İskender kebabının muadili /(als alternative nacht iskender - döner kebab)	Pideli köfte / Kayhan-Kayıhan (Turkish special/Bursa/Tur.)(İskender kebabının muadili / an alternative to iskender döner kebab
Roast sirloin	Roastbeef	Rosbit
Rolled roast veal	Rollbraten	Roulade de veau
Grilled steak	Rostbraten (auf dem Rost)	Bifteck grillé
Rump-steak	Rumpsteak	Rumsteck, rumpsteak
Escalope of veal in cream	Sahneschnitzel	Escalope de veau à la crème

MEAT DISHES (GB.)	FLEISCHGERICHTE (GER.)	PLATS DE VIANDE (F.)
Sauerbraten (braised beef previously marinated in vinegar)	Sauerbraten (in Essigbeize vorherbehandelter Schmorbraten)	Bœuf braisé à l'aigre (bœuf mariné au vinaigre et braisé)
Garnished sauerkraut	Sauerkraut, garniert	Choucroute à l'alsacienne
Sour calf's liver	Saure Leber	Foie de veau à l'aigre
Kebabs, shashliks (meat on skewers)	Schaschliks (Hammelspießchen)	Kebabs, chachliks (brochettes de mouton)
Çöp şiş / shish kebab	Çöp şiş / shish (Spieß) kebab	Çöp şiş / shish kebab
Ham	Schinken	Jambon
Jellied ham, ham in jelly	in Gelee	en gelée
Ham in Madeira sauce	in Madeirasauce	braisé au Madère
with sauerkraut	mit Sauerkraut	à la choucroute
with spinach	mit Spinat	aux épinards
baked in pastry	in Teigkruste	en croûte
ham medallions	Schinkenmedaillons	Médaillons de jambon
Ham steak	Schinkensteak	Steak de jambon
Schlachplatte (fresh sausages, boiled pork meat & sauerkraut)	Schlachtplatte (frische Würste, Wellfleisch, Sauerkraut)	Schlachtplatte (saucisses fraîches, viande de porc bouillie, choucroute)
Braised beef, pot-roast	Schmorbraten	Bœuf braisé
Stewed steak	Schmorsteak	Steak étuvé, stew-steak
Roast pork (domuz rosto)	Schweinsbraten	Rôti de porc
Loin of pork	Schweinsfilet	Filet de porc
Boiled pig's trotters	Schweinsfüße, gekocht	Pieds de porc bouillis
Goulash de pork	Schweinsgulasch	Goulash de porc
Knuckie of pork	Schweinsshaxe	Jarret de porc
Roast knuckle of pork	gebraten	Jarret de porc rôti
Ribs of pork	Schweinskarree	Carré de porc
Ribs of pork with sauerkraut	mit Sauerkraut	Carré de porc à la choucroute
Leg of pork	Schweinskeule	Cuisse de porc
Pork cutlet, pork chop	Schweinskotelett	Côte de porc
Breaded pork cutlet	gebacken	de porc panée
Broiled pork cutlet	gegrillt	de porc grillée

MEAT DISHES (GB.)	FLEISCHGERICHTE (GER.)	PLATS DE VIANDE (F.)
Pork chop paprika sauce	in Paprikasauce	de porc au paprika
Pork liver	Schweinsleber	Foie de porc
Pig's ears	Schweinsohren	Oreilles de porc
Pig's ears with peas	mit Erbsenbrei	de porc à la purée de pois
Shoulder of pork	Schweinsschulter	Épaule de porc
moked loin of pork	Schweinsstelze s. Eisbein	Carré de porc fumé
Roast stuffed sucking-pig	Selchkarree	Porcelet farci rôti
Spit-roasted meat	Spanferkel, gefüllt	Rôti à la broche
Jellied pork cutlet	Spießbraten	Côte de porc en gelée
Boiled beef	Sülzkotelett	Bouilli
Pork goulash with sauerkraut	Suppenfleisch	Goulash de porc à la choucroute
Prime boiled beef	Szegediner Gulasch	Bœuf bouilli
Tartar steak (raw minced steak topped with egg)	Tatarbeefsteak (rohes Hacksteak mit Eigelb)	Steak tartare (steak cru haché avec un jaune d'œuf dessus)
Calf's liver, Tyrolean style (fried liver in sour cream sauce)	Tournedos s.Lendenschnitte	Foie de veau à la tyrolienne (sauté, nappé sauce crème aigre)
Fricassee veal	Weißes Kalbsragout	Blanquette de veau
White sausages	Weißwürste	Boudins blancs
Sour calf's lights	Wiener Beuschel (Saure Lunge)	Mou de veau à l'aigre
Sirloin steak with fried onions	Wiener Rostbraten	Entrecôte à la viennoise (aux oignons)
Wiener schnitzel (breaded veal slice)	Wiener Schnitzel (paniertes Kalbsschnitzel)	Escalope de veau viennoise (escalope panée)
Sausages with cabbage in white wine	Würstchen mit Kohl in Weißwein	Saucisses aux choux au vin blanc
Zampone (pork sausage enwrapped in the skin of a pig's trotter)	Zampone (Wurst in der Haut eines ganzen Schweinsfußes)	Zampone (saucisson enveloppé dans la peau d'un pied de porc)
with lentils	mit Linsen	aux lentilles
with sauerkraut	mit Sauerkraut	à la choucroute

<b>MEAT DISHES (GB.)</b>	<b>FLEISCHGERICHTE (GER.)</b>	<b>PLATS DE VIANDE (F.)</b>
Escalope of veal, gipsystyle (with strips of ham, tongue & mushrooms)	Zigeuner-Schnitzel (mit feinen Schinkenstreifen, Zunge & Champignons)	Escalope de veau zingara (garnie julienne de jambon, langue et champignons)
Ragout of tongue	Zungenragout	Langue de bœuf en ragoût
	Zwiebelrostbraten s. Wiener Rostbraten	
<b>POULTRY (GB)</b>	<b>GEFLÜGEL / KANATLILAR / KÜMES HAYVANLARI (GER)</b>	<b>VOLAILLE (F)</b>
Fried spring chicken	Backhähnchen	Poulet de grain frit
Roast chicken	Brathuhn	rôti
Spring chicken on the spit	vom Spieß	de grain à la broche
Chicken curry	Curryhuhn	sauté au curry
Duck	Ente	Canard
Roast duck	gebraten	Caneton rôti
Roast stuffed duckling	gefüllt	Caneton farci
Duckling	junge	Caneton
Ducking with turnips	mit Mairübchen	Caneton aux navets
Braised duck with olives	mit Oliven	Caneton aux olives
Duckling with oranges	mit Orangen	Caneton à l'orange
Pressed duck	in der Presse	Caneton à la presse
Duckling with red cabbage	mit Rotkohl	Caneton aux choux rouges
Goose (Mehrz. geese)	Gans	Oie
Braised goose with sauerkraut	auf eisässische Art (mit Sauerkraut)	à l'alsacienne (à la choucroute)
Roast goose with apple sauce	auf englische Art (mit Apfelmus)	à l'anglaise (rôtie, sauce aux pommes)
Roast goose	gabraten	rôtie
Goose giblets	Gänseklein	Abatis d'oie
Goose-liver	Gänseleber	Foie gras
Parfait de foie gras	Gänseleber-Parfait	Parfait de foie gras
Pâté de foie gras	Gänseleber-Pastete	Pâté de foie gras
Terrine de foie gras	Gänseleber-Terrine	Terrine de foie gras
Chaud-froid of chicken	Geflügel-Chaufroid	Chaud-froid de volaille
Galantine of chicken	Geflügel-Galantine	Galantine de volaille



<b>POULTRY (GB)</b>	<b>GEFLÜGEL / KANATLILAR / KÜMES HAYVANLARI (GER)</b>	<b>VOLAILLE (F)</b>
Giblets	Geflügelklein	Abatis
Chicken cutlet	Geflügelkotelett	Côtelette de volaille
Chicken croquettes	Geflügelkroketten	Croquettes de volaille
Chicken-livers	Geflügelleber	Foies de volaille
Chicken-livers en brochette	am Spießchen	Brochettes de foies de volaille
Chicken-mousse	Geflügel-Mousse	Mousse de volaille
Grilled chichken	Grillhächnen	Poulet grillé
Chicken baked in pastry	Hahn in Teigkruste	Coq en pâte
Spring chicken	Hähnchen	Poulet nouveau
Hamburg poussins	Hamburger Stubenküken	Poussins de Hambourg
Hen	Henne	Poule
Chicken	Huhn	Poulet
Broiled chicken with bacon	auf amerikanische Art (vom Rost, mit Speck)	grillé à l'américaine (au bacon)
Jellied chicken	in Aspik	en gelée
Boned stuffed chicken	ausgebeint & gefüllt	désossé et farci
Chicken in champagne	in Champagnerwein	au champagne
Chicken curry	mit Curry	sauté au curry
Roast chicken	gebraten	rôti
Roast stuffed chicken	gefüllt	farcî rôti
Grilled chicken	gegrillt	grillé
Boiled chicken	gekocht	bouilli
Chicken, hunter's style (with mushrooms)	nach Jägerart (mit Champignons)	sauté chasseur (aux champignons)
Spring chicken, broiler	junges	nouveau de grain
Casserole of chicken	in der Kasserolle	en cocotte
Chicken Marengo (with mushrooms & tomatoes)	Marengo (sautiert mit Champignons & Tomaten)	sauté Marengo (avec champignons et tomates)
with mayonnaise	mit Mayonnaise	froid mayonnaise
Chicken with paprika	mit Paprika	sauté au paprika
Chicken in cream sauce	in Rahmsauce	sauté à la crème



POULTRY (GB)	GEFLÜGEL / KANATLILAR / KÜMES HAYVANLARI (GER)	VOLAILLE (F)
Grilled chicken	Hun vom Rost	Poulet grillé
Chicken sauté	sautiert	sauté
Spring chicken on the spit	vom Spieß	de grain à la broche
Deviled spring chicken (broiled chicken)	nach Teufels-Art (vom Grill)	grillé à la diable
Breast of chicken		(sauce diable à part)
of chicken Maryland	Hühnerbrustfilet	Suprême de volaille
(with corn fritters & fried bananas)	Maryland (mit kleinen Maisbeignets & gebratenen Bananen)	de volaille Maryland (aux beignets de maïs et bananes frites)
of chicken with salt	mit Pökeltzunge	de volaille à l'écarlate
ox-tongue		
of chicken in cream	in Sahne	de volaille à la crème
Chicken curry	Hühnercurry	Curry de volaille
Stuffed winglets	Hühnerflügel, gefüllt	Ailerons farcis
Chicken fricassee	Hühner+Frikassee	Fricassée de poulet
Leg of chicken	Hühnerkeule	Cuisse de poulet
Chicken mayonnaise	Hühnermayonnaise	Mayonnaise de volaille
Chicken pilaw (pilavlı tavuk)	Hühnerpilaf	Pilaf de volaille
Capon	Kapaun	Chapon
Roast truffed capon	getruffelt	Chapon truffé rôti
Poussin	Küken	Poussin
Grilled poussin	vom Rost	grillé
Fried poussin	auf Wiener Art	frit à la viennoise
	Masthuhn s. Poularde	
Chicken with paprika	Paprika-Huhn	Poulet sauté au paprika
Guinea-fowl, guinea-hen	Perlhuhn	Pintade
Roast guinea-fowl	gebraten	rôtie
Guinea-hen en papillote	en Papillote	en papillote
Guinea-hen in cream	in Rahmsauce	à la crème
Salmi of guinea-hen	Perlhuhnragout	Pintade en salmis
Poulard, poularde	Poularde	Poularde
Poulard with tarragon	mit Estragon	à l'estragon



POULTRY (GB)	GEFLÜGEL / KANATLILAR / KÜMES HAYVANLARI (GER)	VOLAILLE (F)
Boiled poulard	gekocht	bouillie
Truffled poulard	getrüffelt	truffée
Poulard with rice	mit Reis	au riz
Suvorov (stuffed with gooseliver & truffles)	Suworow (mit Gänseleber & Trüffeln)	Souvarov (farcié de foie gras et truffes)
Roast turkey (hindi rosto)	Puterbraten	Dinde rôtie
Breast of turkey (or turkey fillets)	Puterbrustfilet	Suprême de dinde (ou filets de dinde)
	Suprême s. Hühnerbrustfilet	
Pigeon (junge Taube: squab)	Taube	Pigeon (junge Taube: pigeonneau)
Pigeon	gefüllt	Pigeonneau farci
(junge Taube: squab)	vom Grill	à la crapaudine
Roast stuffed squab	sautiert	à la minute
Broiled squab	vom Spieß	rôti à la broche
Pigeon sauté	Taubenpastete	Pâté de pigeons
Pigeon on the spit	Truthahn	Dinde
Pigeon pie	gebraten	rôtie
Turkey (hindi)	gefüllt	farcié rôtie
Roast turkey	gekocht	bouillie
Roast stuffed turkey	geschmort	braisée
Boiled turkey	getrüffelt	truffée
Braised turkey	junger	Dindonneau
Truffed turkey	mit Maronen gefüllt	Dinde farcié aux marrons
Fried spring chicken	Wiener Backhendi	Poulet frit à la viennoise





<b>GAME (GB.) (AV ETi)</b>	<b>WILDBRET (GER.)</b>	<b>GIBIER (F.)</b>
Blackbirds	Amseln	Merles
Capercaillie, wood-grouse	Auerhahn	Coq de bruyère
Snipe	Bekassine	Bécassine
Broiled snipe	vom Rost	grillée
Black-Cock, heath-cock	Birkhahn	Coq des bois
Bald coot, water-hen	Bläßhuhn	Foulque noire
Fallow-deer	Damhirsch	Daim
Thrushes, fieldfares	Drosseln	Grives
à la bonne femme (with diced bacon & croûtons)	nach Hausfrauenart (mit Speckwürfeln & Craûtons)	à la bonne femme (aux lardons et croûtons)
on the spit	am Spieß gebraten	à la broche
with juniper sauce	mit Wacholdersauce	au genièvre
Pheasant	Fasan	Faisan
Roast pheasant	gebraten	rôti
Roast truffled pheasant	getruffelt	truffé
Casserole of pheasant	in der Kasserolle	en casserole
Pheasant with sauerkraut	mit Sauerkraut	à la choucroute
Breast of pheasant	Fasanenbrüstchen	Suprême de faisán
of pheasant in cream	in Rahm	de faisán à la crème
Medallions of pheasant	Fasanenmedallions	Médallions de faisán
Pheasant pie	Fasanenpastete	Pâté de faisán
Beccaficos	Feigendrosseln	Becfigues
	Fettammern s. Ortolane	
Young wild boar	Frischling	Marcassin
Saddle of young wild boar	Frischlingsrücken	Selle de marcassin
Chamois	Gemse	Chamois
Jugged chamois	Gemsenpfeffer	Civet de chamois
Hare	Hase	Lièvre
Hazen grouse, hazel hen	Haselhuhn	Gelinotte
Roast hare	Hasenbraten	Lièvre rôti
Fillets of hare	Hasenfilets	Filets de lièvre
Hare pie	Hasenpastete	Pâté de lièvre
Jugged hare	Hasenpfeffer	Civet de lièvre



<b>GAME (GB.) (AV ETI)</b>	<b>WILDBRET (GER.)</b>	<b>GIBIER (F.)</b>
Ragout of hare	Hasenragout	Ragoût de lièvre
Saddle of hare	Hasenrücken	Râble de lièvre
of hare with juniper	mit Wacholdersauce	de lièvre au genièvre
Deer, stag	Hirsch	Cerf
Roast venison	Hirschbraten	Cerf rôti
Venison steak	Hirschsteak	Steak de cerf
Hunter's brochette	Jadgspeißchen	Brochette du chasseur
Rabbit	Kaninchen	Lapin, lapereau
Fried rabbit	gebacken	Lapereau frit
Roast rabbit	gebraten	Lapin rôti
Rabbit fricassee	Kaninchen-Frikasse	Blanquette de lapin
Jugged rabbit	Kaninchen-Pfeffer	Lapin en civet
Rabbit ragout	Kaninchenragout	Ragoût de lapin, lapin sauté
Lapwing, peewit, pewit	Kiebitz	Vanneau
	Krammetsvögel s. Drosseln	Sarcelle
Teal, teal duck	Krickente (Kriekente)	Alouettes, mauviettes
Larks	Lerchen	Ortolans rôtis
Roast ortolans	Ortolane, gebraten	Perdreau (perdrix)
Partridge	Rebhuhn	Perdreau rôti sur canapé
Roast partridge on toast	gebraten auf Röstbrot	aux choux
Partridge with cabbage	mit Kohl	à la normande (aux pommes reinettes)
Partridge with apples	äuf normannische Art (mit Äpfeln)	à la crème
Partridge in cream	in Rahmsauce	Suprêmes de perdreau
Breast of partridge	Rebhuhnbrüstchen	Chevreuil
Roe (buck), venison	Reh	Chevreuil rôti
Roast venison	Rehbraten	Filets de chevreuil
Fillets of venison	Rehfilets	Cuissot de chevreuil
Haunch of venison	Rehkeule	de chevreuil à la crème
of venison with cream	in Rahmsauce	Côtelette de chevreuil
Venison cutlet	Rehkotelett	de chevreuil Conti (aux lentilles)

<b>GAME (GB.) (AV ETI)</b>	<b>WILDBRET (GER.)</b>	<b>GIBIER (F.)</b>
Venison cutlet Conti (with lentil purée)	Conti (mit Linsenspüree)	de chevreuil Saint-Hubert (avec champignons et sauce poivrade)
Venison cutlet St.Hubert (with mushrooms & poivrade sauce)	St.Hubertus (mit Champignons & Pfeffersauce)	Médallions de chevreuil
Medallions of venison	Rehmedaillons	de chevreuil chasseur (aux champignons et tomates)
of venison, hunter's style (with mushrooms & tomatoes)	nach Jäger-Art (mit Champignons & tomat- en)	de chevreuil à la purée de marrons
Medallions of venison with chestnuts	Rehnsüßchen	Noisettes de chevreuil
Venison noisettes	Rehpastete	Pâté de chevreuil
Venison pie	Rehpfeffer	Civet de chevreuil
Jugged venison	Rehragout	Ragoût de chevreuil
Venison ragout	Rehrücken	Selle de chevreuil
Saddle of venison of venison with mushrooms	nach Försterin-Art (mit Pilzen)	de chevreuil forestière (aux champignons)
Larded saddle of venison	gespickt	de chevreuil piquée
Saddle of venison with cherries	mit Kirschen	de chevreuil aux cerises
of venison with fried bananas	nach Kreolen-Art (mit gebratenen Bananen)	de chevreuil à la créole (aux bananes)
Escalope of venison	Rehschnitzel	Escolope de chevreuil
Escalope of venison with mushrooms	mit Champignons	de chevreuil aux champi- gnons
Venison steak	Rehsteak	Steak de chevreuil
Saddle of venison	Rehziemer	Cimier de chevreuil
Reindeer	Rentier	Renne
Reindeer steak	Rentiersteak	Steak de renne
Wood-pigeon, ring-dove	Ringeltaube	Palombe
Stuffed wood-pigeon	gefüllt	Palombe farcie
Salmi of pheasant	Salmi von Fasan	Salmis de faisan



<b>GAME (GB.) (AV ETI)</b>	<b>WILDBRET (GER.)</b>	<b>GIBIER (F.)</b>
Salmi of partridges	von Rebhühnern	Salmis de perdreaux
Salmi of woodcock	von Schnepfen	Salmis de bécasses
Salmi of wild duck	von Wildente	Canard sauvage en salmis
White grouse, ptarmigan	Schneehuhn	Perdrix des neiges
Woodcock	Schnepfe	Bécasse
Woodcock flambé	flambiert	flambée
Roast woodcock on toast	gebraten auf Röstbrot	rôtie sur canapé
Broiled woodcock	gegrillt	grillée
Breast of woodcock	Schnepfenbrüstchen	Suprême de bécasse
Woodcock pie	Schnepfenpastete	Pâté de bécasses
Black-cock, heath-cock	Spielhahn	Coq des bois
Snipe	Sumpfschnepfe	Bécassine
Water-hen, moor hen	Teichhuhn	Poule d'eau
Quails	Wachteln	Cailles
Roast quails	gebraten	rôties
Quails en casserole	in der Kasserolle	en cocotte
Quails in nests	im Nest	au nid
Quails with rice	mit Reis	au riz
Broiled quails	vom Rost	grillées
Minute quails	auf schnellste Art	a la minute sautées
Quails on the spit	Wachteln vom Spieß	Cailles à la broche
Quails Suworov (stuffed with gooseliver & truffles)	Suworow (mit Gänseleber & Trüffeln gefüllt)	Souvarov (farcies de foie gras et truffes)
Quails roasted in wine-leaves	in Weinblättern gebraten	aux feuilles de vigne
Quails with grapes	nach Winzer-Art (mit Weinbeeren)	à la vigneronne (aux raisins)
Quails with risotto	Wachtel-Risotto	Risotto de cailles
Water-hen, bald coot	Wasserhuhn	Foulque noire
Wild-duck, mallard	Wildente	Canard sauvage
Wild-duck with oranges	mit Orangen	sauvage à la bigarade
Wild rabbit	Wildkaninchen	Lapin de garenne
Game pie, venison pie	Wildpastete	Pâté de gibier



<b>GAME (GB.) (AV ETi)</b>	<b>WILDBRET (GER.)</b>	<b>GIBIER (F.)</b>
Wild boar	Wildschwein	Sanglier
Roast wild boar	Wildschweinbraten	Sanglier rôti
Jugged wild boar	Wildschweinpfeffer	Sanglier en civet
Haunch of wild boar	Wildschweinskeule	Cuissot de sanglier
Haunch of wild boar in sweet & sour sauce	Süß-sauer	Cuissot de sanglier à l'aigre-doux
<b>VEGETABLES (GB.) (SEBZELER)</b>	<b>GEMÜSE (GER.)</b>	<b>LÉGUMES (F.)</b>
Pineapple sauerkraut	Ananaskraut	Choucroute à l'ananas
Artichokes	Artischocken	Artichauts
Fried artichokes	gebacken	frits
Artichokes tartare sauce	mit Tartarensauce	sauce tartare
Artichoke bottoms	Artischockenböden	Fonds d'artichauts
Stuffed artichoke bottoms	gefüllt	d'artichauts farcis
Aubergines, eggplant	Auberginen	Aubergines
Fried aubergines	gebacken	frites
Baked stuffed eggplant	gefüllt	farcies
Sweet potatoes, batatas	Bataten	Patates douces
Kale	Blattkohl	Chou vert
Buttered leaf-spinach	Blattspinat	Épinards à l'anglaise
	Blaukraut s. Rotkohl	
Cauliflower	Blumenkohl	Chou-fleur
Sautéed cauliflower	in Butter	sauté au beurre
Boiled cauliflower	auf englische Art	à l'anglaise
Cauliflower cheese	gratiniert	au gratin, Mornay
Cauliflower with fried breadcrumbs	auf polnische Art (mit Butterbröseln)	à la polonaise (à la mie de pain frite)
Cauliflower pudding	Blumenkohlauflauf	Pain de chou-fleur
French beans	Bohnen, grüne	Haricots verts
Buttered French beans	in Butter	verts au beurre
French beans in cream	in Rahmsauce	verts à la crème
Red beans	, rote	rouges
White beans	, weiße	blancs
Brunswick asparagus	Braunschweiger Spargel	Asperges de Brunswick



VEGETABLES (GB.) (SEBZELER)	GEMÜSE (GER.)	LÉGUMES (F.)
Nettle	Brennessel	Ortie
Broccoli	Brokkoli	Brocolis
Buttered French beans	Butter-Bohnen	Haricots verts au beurre
Buttered green peas	Butter-Erbesen	Petits pois au beurre
(White mushrooms, champignons)	Champignons	Champignons (de Paris)
Stuffed mushrooms	gefüllt	farcis
Broiled mushrooms	gegrillt	grillés
Creamed mushrooms	in Rahmsauce	à la crème
Mushrooms sauté	sautiert	sautés
Belgian endives	Chicorée	Endives
Braised Belgian endives	gedünstet	Endives braisées
Belgian endives in cream	in Rahm	Endives à la crème
Gherkins	Cornichons	Cornichons
Chanterelles	Eierschwämme	Chanterelles, girolles
Endive	Endivie	Chicorée frisée
Green peas	Erbesen	Petits pois
Buttered green peas	in Butter	pois au beurre
Green peas, French style (stewed with small onions & lettuce)	auf französische Art (mit Zwiebelchen & Kopfsalat gedünstet)	pois à la française (cuits avec petits oignons et laitue)
Peas in potato nests	im Nestchen	pois au nid
Minted peas	mit Pfefferminze	pois à la menthe
Green peas with bacon	mit Speck	pois au lard
Fennel, Florence fennel	Fenchelknollen (Finocchi)	Fenouils
Fried fennel	gebacken	frits
Fennel au gratin	gratiniert	au gratin
Early vegetables	Frühgemüse	Primeurs
Vegetables in season	Gemüse der Jahreszeit	Légumes de saison
Assorted vegetables	Gemüseplatte	Légumes variés
Assorted vegetables	mit Ei	variés à l'œuf
Kale	Grünkohl	Chou vert
Cucumbers	Gurken	Concombres



VEGETABLES (GB.) (SEBZELER)	GEMÜSE (GER.)	LÉGUMES (F.)
Stuffed cucumbers	gefüllt	Concombres farcis
Stewed cucumbers	Gurkengemüse	Concombres étuvés
Hop sprouts	Hopfensprossen	Jets de houblon
Mushrooms	Kaiserlinge (Kaiserpilze)	Oronges
Cardoons	Kardonen	Cardons
in cream	in Rahmsauce	à la crème
with marrow sauce	mit Rindermark	à la moelle
Carrots	Karotten	Carottes
Glazed carrots	glaciert	glacées
Carrots in cream	in Rahmsauce	à la crème
Carrots Vichy	Vichy	Vichy
Chick-peas	Kichererbsen	Pois chiches
Celeriac	Knollensellerie	Céleri-rave
Japanese artichokes	Knollenziest	Crosnes
artichokes sauté	sautiert	sautés
Cabbage	Kohl	Chou
Kohlrabi, turnip cabbage	Kohlrabi	Chou-rave (pl.choux-raves)
Meat-filled cabbage rolls	Kohlrouladen	Paupiettes de choux farcies
Swedes, swedish turnips	Kohlrüben	Navets, rutabagas
Lettuce	Kopfsalat	Laitues
Braised lettuce in gravy	gedünstet	braisées au jus
	Kraut s. Kohl	
Horse-radish	Kren	Raifort
Cress	Kresse	Cresson
Pumpkin, squash, gourd	Kürbis	Potiron, courge
Leek	Lauch	Poireaux
Lentils	Linsen	Lentilles
Lentils with bacon	mit Speck	au lard
Mushrooms	Maipilze (Mairitterlinge)	Mousserons
Turnips	Mairüben	Navets
Corn on the cob, sweet corn	Maiskolben	Mais en épis



VEGETABLES (GB.) (SEBZELER)	GEMÜSE (GER.)	LÉGUMES (F.)
(Swiss) chards, spinach beets	Mangold	Blettes, bettes, poirées
Buttered chards	in Butter	Blettes au beurre
Chestnuts	Maronen	Marrons
Horse-radish	Meerrettich	Raifort
Creamed horse-radish	Meerrettichsahne	à la crème
Mixed vegetables	Mischgemüse	Jardinière (ou macédoine) de légumes
Morels	Morcheln	Morilles
Sautéed morels	geröstet	sautées
(Green) peppers, pimien- tos	Paprikaschoten	Poivrons, piments
Stuffed green peppers	gefüllt	Poivrons farcis
Parsnip	Pastinake	Panais
Chanterelles	Pfifferlinge	Chanterelles, girolles
Mushrooms	Pilze	Champignons
Leek	Porree	Poireaux
Leek au gratin	überbacken	au gratin
French beans, string beans	Prinzessbohnen	Haricots verts
Broad beans	Puffbohnen	Fèves
Purée	Püree	Purée
Mushroom purée	von Champignons	de champignons
Purée of peas	von Erbsen	Saint-Germain
Lentil purée	von Linsen	Ésaü
Chestnut purée	von Maronen	de marrons
White bean purée	von weißen Bohnen	soissonnaise
Mashed turnips	von weißen Rüben	de navets
Onion purée	von Zwiebeln	Soubise
Red chicory	Radicchio	Trévisé, chicroée rouge
Radishes	Radieschen	Radis (roses)
Rataouille niçoise (Provençal stew of vegeta- bles)	Ratatouille niçoise (provenzalisches Gemüsaragout)	Ratatouille niçoise (ragoût de légumes variés)
Rocket, garden rocket	Rauke	Roquette





VEGETABLES (GB.) (SEBZELER)	GEMÜSE (GER.)	LÉGUMES (F.)
Radish	Rettich	Radis (blanc ou noir)
Raw vegetable platter	Rohkostplatte	Assiette de crudités
Brussels sprouts	Rosenkohl	Choux de Bruxelles
Sautéed brussels sprouts	in Butter	de Bruxelles sautés
Beetroots, red beets	Rote Rüben	Betteraves
Red cabbage	Rotkohl	Chou rouge
Red cabbage, Flemish style (with apples)	auf flämiische Art (mit Äpfeln)	rouge à la flamande (aux pommes fruits)
Red cabbage with chestnuts	mit Maronen	rouge à la limousine (aux marrons)
Broad beans	Saubohnen	Fèves
Sorrel	Sauerampfer	Oseille
Sauerkraut	Sauerkraut	Choucroute
Garnished sauerkraut	garniert	à l'alsacienne
Black salsify, scorzonera	Schwarzwurzeln	Salsifis, scorsonères
Fried black salsify	gebacken	Salsifis frits
Sautéed black salsify	in Butter	sautés
Celery	Sellerie	Céleris
Braised celery	gedünstet	braises
Celery au gratin	gratiniert mit Parmesan	au parmesan gratinés
Celery in gravy	in Jus	au jus
Creamed celery	in Rahmsauce	à la crème
Asparagus	Spargel	Asperges
with a fried egg	auf Mailänder Art (mit Spiegelei)	à la milanaise (garnies œuf poêlé)
with fried breadcrumbs	auf polnische Art (mit Butterbröseln)	à la polonaise (à la mie de pain frite)
au gratin		au gratin
vinaigrette sauce	überbacken	à la vinaigrette
with melted butter	mit Vinaigrette	au beurre fondu
Broccoli	mit zerlassener Butter Spargelkohl	Brocolis
Asparagus tips	Spargelspitzen	Pointes d'asperges
Asparagus tips in cream	in Rahmsauce	d'asperges à la crème

VEGETABLES (GB.) (SEBZELER)	GEMÜSE (GER.)	LÉGUMES (F.)
Beans & bacon	Speckbohnen	Haricots blancs au lard
Lentils with bacon	Specklinsen	Lentilles au lard
Spinach	Spinat	Épinards
Buttered leaf-spinach	(Blattspinat)	à l'anglaise
Creamed spinach	mit Rahm	à la crème
Spinach with fried egg	mit Spiegelei	à l'œuf
Spinach pudding	Spinat-Auflauf	Pain d'épinards
Spinach purée	Spinatpüree	Purée d'épinards
Mushrooms, ceps	Steinpilze	Cèpes
Mushrooms Bordelaise (sauté with shallots)	auf Bordelaiser Art (mit Schalotten geröstet)	à la bordelaise (sautés aux échalotes)
Mushrooms, Provençal style (sautéed in oil with garlic)	auf provenzalische Art (mit Knoblauch in Öl geröstet)	à la provençale (sautés à l'huile avec ail et persil)
au gratin	überbacken	au gratin
Mushroom caps	Steinpilzköpfe	Chapeaux de cèpes
Broiled mushroom caps	grilliert	de cèpes grillés
Tomatoes	Tomaten	Tomates
Baked stuffed tomatoes	gefüllt	farcies
Rice-stuffed tomatoes	mit Reis gefüllt	farcies de riz
Broiled tomatoes	gegrillt	grillées
Baked tomatoes Provençal (baked halved tomatoes filled with breadcrumbs & garlic)	auf provenzalische Art (mit Brösel & Knoblauch gra- tinierte Tomaten)	à la provençale (demi tomates gratinées, farcies mie de pain, ail et persil haché)
Tomatoes au gratin	überbacken	au gratin
Jerusalem artichokes	Topinamburs	Topinambours
Truffles	Trüffeln	Truffes
baked in ashes	in der Asche gebraten	sous la cendre
in napkin	in der Serviette	à la serviette
White beans	Weißer Bohnen	Haricots blancs
Turnips	Weißer Rüben	Navets, raves
White cabbage	Weißkohl (Weißkraut)	Chou blanc
Braised cabbage	gedünstet	blanc braisé

<b>VEGETABLES (GB.) (SEBZELER)</b>	<b>GEMÜSE (GER.)</b>	<b>LÉGUMES (F.)</b>
Stuffed cabbage	gefüllt	blanc farci
Savoy	Wirsing	Chou de Milan
Courgettes, zucchini	Zucchini	Courgettes
Fried courgettes	gebacken	frites
Baked stuffed courgettes	gefüllt	farciés
Zucchini sauté	geröstet	sautées
Onions	Zwiebeln	Oignons
Fried onion rings	gebacken	frits
Stuffed onions	gefüllt	farciés
Smothered onions	geschmort	braisés
Glazed onions	glaciert	glacés
<b>POTATOES (GB.) PATATES</b>	<b>KARTOFFELN (GER.)</b>	<b>POMMES DE FERRE (F.)</b>
Potatoes Anna (sliced potatoes cake-shaped & baked in a special casserole)	Anna-Kartoffeln (Kartofelscheiben fladenförmig in einer Kasserolle überbacken)	Pommes Anna (galette de pommes de terre)
Boulangère potatoes (baked with onions)	Bäckerin-Kartoffeln (mit Zwiebeln gebraten)	boulangère (cuites au four avec oignons)
Croquette potatoes amandine	Berny-Kartoffeln (Kartoffelkroketten mit Mandeln paniert)	Berny (pommes croquettes aux amandes)
Bouillon potatoes	Bouillon-Kartoffeln	au bouillon
Sauté potatoes, fried potatoes	Bratkartoffeln	sautées, rissolées
Potato chips	Chips	chips
Steamed potatoes	Dampfkartoffeln	vapeur
Dauphine potatoes (potato croquettes)	Dauphine-Kartoffeln (Kartoffelkroketten)	dauphine (croquettes en forme de bouchon)
Dill potatoes	Dillkartoffeln	à l'aneth
Duchesse potatoes (croquette potatoes browned in the oven)	Duchesse-Kartoffeln (Kartoffelkroketten im Backofen gebraten)	duchesse (pommes croquettes cuites au four)
Stuffed potatoes	Gefüllte Kartoffeln	farciés



POTATOES (GB.) PATATES	KARTOFFELN (GER.)	POMMES DE FERRE (F.)
Roast potatoes, baked potatoes	Geröstete Kartoffeln	rôties
Potato soufflé	Kartoffelauflauf	Soufflé de pommes
Mashed potatoes	Kartoffelbrei	Pommes en purée
Potato chips	Kartoffelchips	Pommes chips
Potato dumplings	Kartoffelößchen	Gnocchi de pommes
Potato croquettes	Kartoffelkroketten	Pommes (en) croquettes
Baked jacket potatoes (baked in their skins)	Kartoffeln, in der Schale gebraten	Pommes au four (cuites telles quelles)
Potato nests	Kartoffelnestchen	Nids de pommes paille
Potato cakes	Kartoffelpuffer	Galettes de pommes
Mashed potatoes	Kartoffelpüree	Pommes en purée
Caraway potatoes	Kümmelkartoffeln	au cumin
Lorette potatoes (potato croquettes)	Lorette-Kartoffeln (Kartoffelkroketten)	Lorette (pommes croquettes au fromage)
Lyonnaise potatoes (fried with onions)	Lyoner Kartoffeln (mit Zwiebeln gebraten)	à la lyonnaise (sautées aux oignons)
Macaire potatoes (potato cake fried in butter)	Macaire-Kartoffeln (Kartoffelkuchen in der Pfanne gebräunt)	Macaire (galette de pommes rissolée à la poêle)
Maitre d'hôtel potatoes (creamed potatoes with parsley)	Maitre-Kartoffeln (Rahmkartoffeln mit Petersilie) Kartoffeln	maitre d'hôtel (pommes à la crème avec persil)
New potatoes	Neue Kartoffeln	nouvelles
Noisette potatoes (nut-shaped potatoes fried in butter)	Nußkartoffeln (haselnuß große Bratkartoffeln)	noisettes (pommes rissolées en forme de noisette)
Parisienne potatoes (noisette potatoes rolled in meat-glaze)	Pariser Kartoffeln (Nuß Kartoffeln in Fleischglaze gerollt)	à la parisienne (pommes noisettes à la glace de viande)
Parmentier potatoes (cube-shaped potatoes fried in butter)	Parmentier-Kartoffeln (gebratene Kartoffel würfel)	Parmentier (pommes en gros dés, sautées au beurre)



POTATOES (GB.) PATATES	KARTOFFELN (GER.)	POMMES DE FERRE (F.)
Potatoes in their jackets, jacket potatoes	Pellkartoffeln (Kartoffeln in der Schale)	en robe des champs
Parsley potatoes	Petersilienkartoffeln	Pommes persillées
Shoestring potatoes	Pommes allumettes	allumettes
potato croquettes	croquettes	croquettes
French fried potatoes	frites	frites
Soufflé potatoes (sliced potatoes fried twice in deep fat)	soufflées (zweimal in heißem Fett gebacken)	soufflées (pommes frites, replongées dans la friture)
Pont-Neuf potatoes (French-fried potato strips)	Pont-Neuf-Kartoffeln (gebackene Kartoffel stäb- chen)	Pont-Neuf (pommes frites en bâtonnets)
Creamed potatoes	Rahmkartoffeln	à la crème
	Reibekuchen	
	s.Kartoffelpuffer	
Rosemary potatoes	Rosmarinkartoffeln	au romarin
Roast potatoes	Röstkartoffeln	rôties
Boiled potatoes	Salzkartoffeln	à l'anglaise, nature
Savoy potatoes (potatoes gratinated with broth & cheese)	Savoyer Kartoffeln (mit Käse & Bouillon über- backen)	Gratin savoyard (gratin de pommes au bouillon et fro- mage)
Mousseline potatoes (mashed potatoes with whipped cream)	Schaumkartoffeln (Kartoffelpüree mit Schlag sahnemisch)	Pommes mousseline (purée de pommes à la crème)
Château potatoes (olive- shaped fried potatoes)	Schloßkartoffeln (oliven förmig geschnitten & in Butter gebraten)	château (tournées en grosses olives et cuites au beurre)
Fondant potatoes	Schmeizkartoffeln	fondantes
Stewed potatoes	Schmorkartoffeln	à l'étuvée
Sauté potatoes	Schwenkartoffeln	sautées
Bacon potatoes	Speckkartoffeln	au lard
Shoestring potatoes	Streichholzkartoffeln	Pommes allumettes
Potato straws	Strohkartoffeln	paille
Sweet potatoes	Süßkartoffeln	Patates douces



<b>POTATOES (GB.) PATATES</b>	<b>KARTOFFELN (GER.)</b>	<b>POMMES DE FERRE (F.)</b>
Potatoes au gratin	Überbackene Kartoffeln	Pommes au gratin
Surprise potatoes	Überraschungskartoffeln	en surprise
Voisin potatoes (cake of potato, butter & cheese)	Voisin-Kartoffeln (Kartoffeltörtchen mit Butter & Käse)	Voisin (galette de pommes au beurre et fromage)
Lattice French fried potatoes	Waffelkartoffeln	gaufrettes
<b>FARINACEOUS DISHES (GB.) HAMUR İŞLERİ &amp; PİRİNÇ</b>	<b>TEIGWAREN &amp; REIS (GER.)</b>	<b>PÂTES ET RIZ (F.)</b>
Noodles	Bandnudeln	Nouilles
with butter	mit Butter	Nouilles au beurre
in cream sauce	in Rahmsauce	Nouilles à la crème
Buttered rice	Butterreis	Riz au blanc, riz au beurre
Cannelloni (stuffed rolls of noodle dough)	Cannelloni (gefüllte Nudelteigrollen)	Cannelloni (sorte de gros macaroni farci)
Florentine cannelloni	auf Florentiner Art	à la florentine
Cannelloni à la niçoise	auf Nizzaer Art	à la niçoise
Crêpes with ham	Crêpes mit Schinken	Crêpes au jambon
with spinach	mit Spinat	à la florentine
Curried rice	Curryreis	Riz au curry
Vermicelli	Fadennudeln	Vermicelle, vermicelles
Lenten ravioli	Fastenravioli	Ravioli farcis au maigre
Fish risotto	Fischrisotto	Risotto de poisson
Green noodles	Grüne Bandnudeln	Nouilles vertes
Ginger rice	Ingwerreis	Riz au gingembre
Potato dumplings	Kartoffelklößchen	Gnocchi de pommes
Creole rice	Kreolenreis	Riz à la créole
Lasagne, noodles	Lasagne	Lasagnes, lasagne
Liver dumplings	Leberknödel	Boulettes de foie
Macaroni	Makkaroni	Macaroni
with butter	mit Butter	au beurre
cheese, au gratin	gratiniert	au gratin
with tomato sauce	mit tomatensauce	à la napolitaine
Macaroni timbale	Makkaroni-Pastete	Timbale de macaroni



FARINACEOUS DISHES (GB.) HAMUR İŞLERİ & PİRİNÇ	TEIGWAREN & REIS (GER.)	PÂTES ET RIZ (F.)
Gnocchi à la parisienne (baked dumplings of flour, egg & cheese)	Pariser Gnocchi (gratini- erte Klößchen aus Brandteig)	Gnocchi à la parisienne
Pilaff, pilau, pilaw, Pilav	Pilaf (Pilaw, Pilau, Pilav)	(gnocchi de pâte à choux fromagée)
Polenta (maize porridge)	Polenta (Maisbrei)	Riz pilaf, riz pilaw, pilav
Ravioli	Ravioli	Polenta
in gravy	mit Jus	Ravioli, raviolis
Cheese-filled ravioli	mit Quarkfüllung	au jus
Rice	Reis	au fromage blanc
Greek rice	auf griechische Art	Riz
Rice with mushrooms	mit Steinpilzen	à la grecque
Rice croquettes	Reiskroketten	aux cèpes
Rice timbale, rice pie	Reis-Pastete	Croquettes de riz
Rice ring (with mush- rooms)	Reisring (mit Pilzen)	Timbale de riz
Risotto	Risotto	Turban de riz (aux champi- gnons)
Chicken-liver risotto	mit Hühnerleber	Risotto
Saffron risotto	auf Mailänder Art	aux foies de volaille
Mushroom risotto	(mit Safran gewürzt)	à la milanaise (risotto safrané)
Truffle risotto	mit Steinpilzen	aux cèpes
Gnocchi à la romaine (semolina dumplings)	mit Trüffeln	aux truffes
Saffron rice	Römische Gnocchi (grati- nierte Grießklößchen)	Gnocchi à la romaine
Bread dumplings	Safranreis	(à la semoule)
Spaghetti	Semmelknödel	Riz auf safran
with bolognese sauce, with meat sauce	Spaghetti	Boulettes de pain
with anchovies	auf Bologneser Art (mit Fleischsauce)	Spaghetti, spaghettis
with tomato sauce	mit Sardellen	à la bolonaise (avec petit ragoût de bœuf)

<b>FARINACEOUS DISHES (GB.) HAMUR İŞLERİ &amp; PİRİNÇ</b>	<b>TEIGWAREN &amp; REIS (GER.)</b>	<b>PÂTES ET RIZ (F.)</b>
Spätzle (small flour dumplings)	mit Tomatensauce	aux anchois
	Spätzle	sauce tomate
Bacon dumplings	Speckknödel	Spätzle (petits gnocchi de farine)
Tagliatelle, noodles	Tagliatelle	Boulettes au lard
Tyrolean dumplings	Tiroler Knödel	Tagliatelles
		Boulettes à la tyrolienne
<b>SALADS (SALATALAR) (GB.)</b>	<b>SALATE (GER.)</b>	<b>SALADES (F.)</b>
<u>Plain salads</u>	<u>Einfache Salate</u>	<u>Salades simples</u>
Cauliflower salad	Blumenkohlsalat	Salade de choux-fleurs
French bean salad	Bohnensalat, grüner	de haricots verts
Water-cress salad	Brunnenkressesalat	de cresson de fontaine
Belgian endive salad	Chicoréesalat	d'endives
Escarote salad	Eskariolsalat	de scarole
Corn salad, lamb's lettuce salad	Feldsalat	de mâche, de doucette
Endive salad	Friséesalat	de chicorée frisée
Garden cress salad	Gartenkressesalat	de cresson alénois
Green salad	Grüner Salat	verte
Cucumber salad	Gurkensalat	de concombres
Potato salad	Kartoffelsalat	de pommes (de terre)
Lettuce salad	Kopfsalat	de laitue
Lettuce salad in cream	in Sahne	de laitue à la crème
Cabbage salad, cole-slaw	Krautsalat	de choux
Dandelion salad	Löwenzahnsalat	de pissenlit
Spinach beet salad	Mangoldsalat	de bettes
Green pepper salad	Paprikasalat	de poivrons
Purslane salad	Portulaksalat	de pourpier
Red chicory salad	Radicchio-Salat	de trévisé
Radish salad	Radieschensalat	de radis (roses)
Cos (lettuce) salad	Rapunzelsalat s. Feldsalat	romaine





SALADS (SALATALAR) (GB.)	SALATE (GER.)	SALADES (F.)
Beetroot salad	Römischer Salat	de betterave
Red cabbage salad	Rote-Rüben-Salat	de choux rouges
Salad in season	Rotkohlsalat	de saison
Black salsify salad	Salat der Saison	Salade de salsifis
Celery salad	Schwarzwurzelsalat	de céleri
Celeriac salad	Selleriesalat (Knollensellerie)	de céleri-rave
Cos lettuce salad, romaine	Sommerendiviensalat	romaine
Asparagus salad	Spargelsalat	d'asperges
Tomato salad	Tomatensalat	de tomates
Escarole salad	Winterendiviensalat	de scarole
Compound salads	Zusammengesetzte Salate	Salades composées
Fancy salad	Bunter Salat	Salade mêlée
Carmen salad (red peppers, breast of chicken, peas & rice)	Carmen-Salat (rote paprikaschoten, Hühnerfleisch, Erbsen, Reis)	Carmen (poivrons rouges, blanc de poule, petits pois, riz)
Francillon salad (potatoes, mussels, truffles)	Francillon-Salat (Kartoffeln, Miesmuscheln, Trüffeln)	Francillon (pommes de terre, moules et truffes)
Springtime salad	Frühlingssalat	printanière
Mixed salad	Gemischter Salat	mêlée, panachée
Tomato & cucumber salad	Gurken-Tomaten-Salat	de concombres et
Lorette salad (lamb's lettuce, celery, beetroot. French dressing)	Lorette-Salat (Rapunzel, Staudensellerie, rote Rüben)	Lorette (mâche, céleri,
Mimosa salad (lettuce hearts, oranges, bananas, grapes, Cream & lemon juice)	Mimosa-Salat (Kopfsalatherzen, Orangen, Bananen, Trauben, Sahne & Zitronensaft)	betteraves, Vinaigrette)
Ninon salad (lettuce & orange salad)	Ninon-Salat (Kopfsalat & Orangenspalten)	Salade mimosa (cœurs de laitue, oranges, bananes, raisins. Crème et jus de citron)

<b>SALADS (SALATALAR) (GB.)</b>	<b>SALATE (GER.)</b>	<b>SALADES (F.)</b>
Niçoise salad (a: string beans, potatoes, tomatoes, olives; b: raw tomatoes, onions & green peppers with anchovies & black olives)	Nizzaer Salat (a: Kartoffeln, grüne Bohnen, Tomaten, Oliven; b: rohe Tomaten, Paprikaschoten & Zwiebeln mit Sardellen & schwarzen Oliven)	niçoise (a: haricots verts, pommes de terre, tomates, olives; b: tomates, poivrons, oignons crus avec anchois et olives noires)
Rachel salad (celery, artichoke bottoms, truffles, potatoes, asparagus tips)	Rachel-Salat (Sellerie, Artischockenböden, Kartoffeln, Trüffeln & Spargelspitzen)	Rachel (céleri, truffles, pommes de terre, fonds d'artichauts, pointes d'asperges)
Rice salad	Reissalat	de riz
Russian salad (mixed vegetable salad dressed with mayonnaise)	Russischer Salat (Gemüsesalat mit Mayonnaise angemacht)	russe (salade de légumes divers liée à la mayonnaise)
Black & white salad (potatoes & black truffles. Mayonnaise)	Schwarzweißer Salat (Kartoffeln & Trüffeln, Mayonnaise)	demi-deuil (pommes de terre et truffes noires.)
Lettuce-tomato salad	Tomaten-Kopfsalat	de tomate et laitue
Tosca salad (celery, poultry, truffles, Parmesan, Mayonnaise)	Tosca-Salat (Sellerie, Geflügel, Trüffeln, Parmesan, Mayonnaise)	
Waldorf salad (apples, celeriac & walnuts. Mayonnaise)	Waldorf-Salat (Äpfel, Knollensellerie, Walnüsse. Mayonnaise)	Waldorf (pommes reinettes, céleri-rave, noix. Mayonnaise)
<b>CHEESE (PEYNİR) (GB.)</b>	<b>KÄSE (GER.)</b>	<b>FROMAGES (F.)</b>
Camembert (soft cheese)	Camembert (Weichkäse)	Camembert (Weichkäse)
Edam (cheese)	Edamer	Edamer
Emmenthal	Emmentaler	Emmentaler
Swiss fondue	Fondue (Käsefondue)	Fondue (Käsefondue)
Gorgonzola (blue cheese)	Gorgonzola (Blauschimmelkäse)	Gorgonzola (Blauschimmelkäse)
Swiss cheese, gruyère	Gruyère (Greyerzer)	Gruyère (Greyerzer)
Dutch cheese	Holländer Käse	Holländer Käse
Cheese soufflé	Käse-Auflauf	Käse-Auflauf
Choice of cheese	Käseauswahl	Käseauswahl
Cheese tray	Käseplatte	Käseplatte

<b>CHEESE (PEYNİR) (GB.)</b>	<b>KÄSE (GER.)</b>	<b>FROMAGES (F.)</b>
Cheese-straws	Käsestangen	Käsestangen
Ramekins, cheese tartlets	Käsetörtchen	Käsetörtchen
Cheese-puffs	Käsewindbeutel	Käsewindbeutel
Green cheese	Kräuterkäse	Kräuterkäse
Liptauer (curds of ewe's milk with paprika & caraway-seeds)	Liptauer (Quark aus Schafmilch, mit Paprika & Kümmel)	Liptauer (fromage blanc de brebis, additionné de paprika et cumin)
Parmesan (cheese)	Parmesankäse	Parmesan
Petit-suisse (soft full-cream cheese)	Petit-suisse (milder frischer Rahmkäse)	Petit suisse (fromage frais très gras)
Cottage cheese, curd(s)	Quark	Fromage blanc
Cream-cheese	Rahmkäse	Fromage à la crème
Smoked-cheese	Räucherkäse	Fromage fumé
Roquefort (blue cheese of ewe's milk)	Roquefort (Schimmelkäse aus Schafmilch)	Roquefort (fromage persillé)
Ewe's milk cheese	Schafkäse	Fromage de brebis
Cheese spread	Streichkäse	à tartiner, fondu
	Topfen s.Quark	
Goat-cheese	Ziegenkäse	Fromage de chèvre
<b>SWEETS &amp; ICE CREAMS TATLILAR (GB.)</b>	<b>SÜßSPEISEN, EISSPEISEN (GER.)</b>	<b>ENTREMETS ET GLACES (F.)</b>
Pineapple with kirsch	Ananas mit Kirsch	Ananas au kirsch
with whipped cream	mit Schlagsahne	Ananas à la Chantilly
Pineapple fritters	Ananasbeignets	Beignets d'ananas
Pineapple tartlets	Ananastörtchen	Tartelettes à l'ananas
Baked stuffed apple	Apfel nach Hausfrauenart (Bratapfel mit Butter & Zucker gefüllt)	Pomme à la bonne
Meringue apple	mit Meringe	femme (pomme au four remplie beurre et sucre)
Apple dumpling (apple baked in pastry)	im Schlafrock	meringuée
Apple fritters	Apfelbeignets	Pomme en surprise
Apple charlotte (stewed apples enclosed in bread slices)	Apfel-Charlotte (Apfelmus in Brotscheibenhülle)	Beignets de pommes



<b>SWEETS &amp; ICE CREAMS TATLILAR (GB.)</b>	<b>SÜßSPEISEN, EISSPEISEN (GER.)</b>	<b>ENTREMETS ET GLACES (F.)</b>
Apple tart, apple pie	Apfelkuchen	Charlotte aux pommes
Apple fritters	Apfelringe, gebacken	(marmelade de pommes dans enveloppe de tranches de pain)
Apple strudel	Apfelstrudel	Tarte aux pommes
Apple turnover	Apfeltasche	Beignets de pommes
Apple tart	Apfeltorte	Strudel aux pommes
Apricot soufflé	Aprikosenauflauf	Chausson aux pommes
Apricot tart	Aprikosentorte	Tarte aux pommes
French toast	Arme Ritter	Soufflé aux abricots
Assorted pastries	Auswahl an Backwerk	Tarte aux abricots
Variety of pies & cakes	an Torten	Pain doré, pain perdu
Rum baba	Baba mit Rum	Pâtisserie assortie
Pastry	Backwerk	Gâteaux variés
Meringue Chantilly	Baiser mit Schlagsahne	Baba au rhum
Bananas flambé	Bananen, flambiert	Pâtisserie, petit gâteau
Banana fritters	Bananenbeignets	Meringue Chantilly
Bavarian cream (custard with gelatine & whipped cream added)	Bayerische Creme (kalte Süßspeise aus Eiercreme & Schlagsahne)	Bananes flambées
Ribboned Bavarian cream	Schichtcreme	Beignets de bananes
Bavarian chocolate cream	Schokoladencreme	Bavarois (entremets froid à base de crème anglaise et Chantilly)
Bavarian vanilla cream	Vanillecreme	à la vanille
Fritters	Beignets	Beignets
Doughnuts	Berliner Pfannkuchen	Beignets viennois
Pear Alma (stewed in port wine, decorated with whipped cream)	Birne Alma (in Portwein pochiert, mit Schlagsahne verziert)	Poire Alma (pochée au porto, décorée de crème Chantilly)
Condé (pear on rice border with fruit sauce)	Condé (Birne auf Reisrand mit Fruchtsauce)	Condé (dressée sur socle de riz et arrosée de sirop)
Helena (pear on vanilla ice-cream with hot chocolate sauce)	Helene (auf Vanilleeis, mit heißer Schokoladensauce)	Belle-Hélène (sur glace vanille avec sauce au chocolat chaude)



<b>SWEETS &amp; ICE CREAMS TATLILAR (GB.)</b>	<b>SÜßSPEISEN, EISSPEISEN (GER.)</b>	<b>ENTREMETS ET GLACES (F.)</b>
Sponge cake	Biskuittorte	Biscuit de Savole
Swiss roll, baked jam roll	Biskuitrolle	Biscuit roulé
Biscuits, Am. cookies	Biskuits	Gâteaux secs, biscuits
French blancmange (almondmilk & gelatine)	Blancmanger (Mandelmilch mit Gelatine)	Blanc-manger (gelée aux amandes)
Baked apple	Bratapfel	Pomme au four
Brioche	Brioche	Brioche
Butter-cream cake	Buttercremetorte	Gâteau à la crème au beurre
Cassata (ice-cream slice with candied fruits)	Cassata (Eisschnitte mit kandierten Früchten)	Cassate (glace composée aux fruits confits)
Champagne sherbet	Champagner-Sorbet	Sorbet au champagne
Charlotte russe (custard with casing of sponge bis- cuits)	Charlotte russe (Vahillecreme in Biskuithülle)	Charlotte russe (bavarois à la vanille dans enveloppe de biscuits)
Custard	Creme, englische	Crème anglaise
Crème Beau rivage (cus- tard with whipped cream)	Creme Beau-Rivage (Vanillecreme mit Schlagsahne verziert)	Crème Beau rivage (crème renversée à la vanille, décorée Chantilly)
Crêpes Georgette (with slices of pineapple)	Georgette (mit Ananasscheiben)	Georgette (fourrées tranches d'ananas)
Pancakes with jam	mit Konfitüre	aux confitures
Norman pancakes (with apples)	äuf normannische	à la normande (aux pom- mes)
Crêpes Suzette (spread with orange butter cream)	Suzette (mit Orangen Buttercreme bestrichen)	Suzette (tartinées avec un beurre d'orange au curaçao)
Cabinet pudding (made of custard, sponge biscuits & candied fruits)	Diplomatenpudding (aus Eiercreme, Löffelbiskuits, kandierten Früchten)	Pudding diplomate (fait de crème anglaise, biscuits et fruits confits)
Éclairs	Eclairs	Éclairs
Coffee éclairs	(Mokka-)	au café
Chocolate éclairs	(Schokoladen-)	au chocolat
Custard	Eiercreme	Crème anglaise
Ice-cream	Eis	Glace
Ice-soufflé	Eisauflauf	Soufflé glacé



<b>SWEETS &amp; ICE CREAMS TATLILAR (GB.)</b>	<b>SÜßSPEISEN, EISSPEISEN (GER.)</b>	<b>ENTREMETS ET GLACES (F.)</b>
Ice-cream meringue	Eisbaiser	Meringue glacée
Sundae, coupe	Eisbecher	Coupe glacée
Coupe Jacques (ice cream with fruit salad)	Eisbecher mit Früchten	Coupe Jacques
Jamaica coupe	Jamaika	(macédoine garnie de glace)
Bombe (cone-shaped ice-cream)	Eisbombe (zwei Eissorten in Halbkugelform)	Jamaïque
Bombe Nesselrode (chestnut & vanilla ice-cream)	Nesselrode (außen kastanieneis, innen Vanilleeis)	Bombe glacée (glace composée)
Iced coffee with whipped	Eiskaffee	Bombe Nesselrode (glace aux marrons, bombe vanille)
Ice cream tart cream	Eistorte	Café liégeois
Custard	Englische Creme	Gâteau glacé
Strawberries with cream	Erdbeeren mit Sahne	Crème anglaise
Bavarian strawberry cream	Erdbeer-Bavarois	Fraises à la Chantilly
Strawberry cream	Erdbeer-Creme	Bavarois aux fraises
Strawberry ice-cream	Erdbeer-Eis	Crème aux fraises
Strawberry parfait	Erdbeerhalbgefrorenes	Glace aux fraises
Strawberry mousse	Erdbeer-Mousse	Parfait aux fraises
Strawberry tart	Erdbeer-Torte	Mousse aux fraises
Doughnuts	Faschingskrapfen	Tarte aux fraises
Flummery of semolina & fruit sauce	Flammeri (Grieß) mit Fruchtsaft	Beignets viennois
Fruit ice-cream	Frucht-Eis	Pudding de semoule sauce aux fruits rouges
Prince Pückler ice-cream	Fürst-Pückler-Eis (Vanille-, Erdbeer & Schokoladeeis)	Glace aux fruits
(vanilla, strawberry & chocolate ice-cream)		Glace prince Pückler (glace vanille, fraise et chocolat)
Mixed ice-cream	Gemischtes Eis	Glace panachée
Granita	Granita (Gramolata)	Granité
Semolina pudding	Grießpudding	Pudding de semoule

<b>SWEETS &amp; ICE CREAMS TATLILAR (GB.)</b>	<b>SÜßSPEISEN, EISSPEISEN (GER.)</b>	<b>ENTREMETS ET GLACES (F.)</b>
Gugelhupf (yeast cake with raisins)	Gugelhupf	Kouglof, kugelhopf
Parfait; mousse	Halbgefrorenes	Parfait; mousse glacée
Harlequin soufflé (half vanilla, half chocolate)	harlekin-Auflauf (Vanille & Schokolade)	Soufflé Arlequin (moitié vanille, moitié chocolat)
Filbert soufflé	Haselnuß-Auflauf	Soufflé aux avelines
Hazelnut cream	Haselnuß-Creme	Crème aux noisettes
Hazelnut ice-cream	Haselnuß-Eis	Glace aux noisettes
Raspberry ice-cream	Himbeer-Eis	Glace aux framboises
Raspberry jelly	Himbeer-Gelee	Gelée de framboises
Wedding cake	Hochzeitstorte	Gâteau de mariage
Currant jelly	Johannisbeer-Gelee	Gelée de groseilles
Currant tart	Johannisbeer-Torte	Tarte aux groseilles
Coffee ice-cream	Kaffee-Eis Diplomaten	Glace au café
Coffee parfait	Kaffee-Parfait	Parfait au café
Kaiserschmarren (raisin omelet cut up into pieces)	Kaiserschmarren (Rosinen-Omelette in Stücke zerkleinert)	Kaiserschmarren (omelette aux raisins coupée en morceaux)
Caramel custard	Karamelcreme	Crème au caramel
Cheese-cake	Käsekuchen	Gâteau au fromage blanc
Biscuits, Am. cookies	Kekse	Gâteaux secs, biscuits
Cherries jubilee (flaming cherries)	Kirschchen auf Jubiläums	Cerises jubilé (flambées au kirsch)
Cherry strudel	Kirschstrudel	Strudel aux cerises
Cherry tart, cherry pie	Kirschtorte	Tarte aux cerises
Cherry tartlet	Kirschtörtchen	Tartelette aux cerises
Kirsch soufflé	Kirschwasserauflauf	Soufflé au kirsch
Plum-cake, fruit-cake	Königskuchen	Cake
Fritters	Krapfen (Küchel)	Beignets
Doughnuts	Krapfen (Faschings)	Beignets viennois
Cake, tart	Kuchen (Mürbeteig)	Tarte, flan
Tart, flan, shortcake	Lebkuchen	Pain d'épice

<b>SWEETS &amp; ICE CREAMS TATLILAR (GB.)</b>	<b>SÜßSPEISEN, EISSPEISEN (GER.)</b>	<b>ENTREMETS ET GLACES (F.)</b>
Gingerbread	Linzer Torte (Mürbeteig mit Zimt & Nüssen, mit Marmelade bestrichen)	Linzertarte (tarte en pâte brisée à la cannelle, garnie de confiture)
Linzer tart (latticed jam tart made of spiced short pastry with nuts)	Löffelbiskuits	Biscuits à la cuiller
Sponge biscuits, lady fingers	Makronen	Macarons
Macaroons	Mandarinen-Eis	Glace aux mandarines
Tangerine ice-cream	Mandel-Auflauf	Soufflé aux amandes
Almond soufflé	Mandeltorte	Gâteau aux amandes
Almond cake	Marillenknödel	Chaussons aux abricots
Apricot dumplings	Melone (eisgekühlte)	Melon frappé
Iced melon	Meloneneis	Glace au melon
Melon ice-cream	Meringe	Meringue
Meringue	Milchreis	Riz au lait
Rice pudding	Mohnkuchen	Gâteau au pavot
Poppy-seed cake	Mokkaeis	Glace au café
Coffee ice-cream	Mokkaparfait	Parfait au café
Coffee parfait	Mokkasoufflé	Soufflé au café
Coffee soufflé	Mokkatorte	(Gâteau) moka
Mocha cake	Montblanc (Kastanien püree mit Schlagsahne bedeckt)	Mont-blanc (purée de marrons garnie Chantilly)
Mont-Blanc (mashed chestnuts topped with whipped cream)	Mousse (gefrorene aromatisierte Schlagsahne)	Mousse glacée; parfait
Mousse (frozen whipped cream mixture)	Napfkuchen	Napfkuchen (baba allemand)
Napfkuchen (yeast cake with raisins)	Neapolitanisches Eis (Eisschnitte aus drei verschiedenfarbigen Lagen)	Tranche napolitaine (glace à trois parfums disposée en couches)
Neapolitan ice (ice-cream made in layers of different flavours)	Nougat-Eis	Glace au nougat
Nougat ice-cream	Nußeis	Glace aux noisettes



<b>SWEETS &amp; ICE CREAMS TATLILAR (GB.)</b>	<b>SÜßSPEISEN, EISSPEISEN (GER.)</b>	<b>ENTREMETS ET GLACES (F.)</b>
Hazelnut ice-cream	Nußtorte	Gâteau aux noix
Nut cake	Obstkuchen	Tarte aux fruits
Fruit tart, fruit pie	mit Meringe	aux fruits meringuée
Fruit meringue pie	Obstsalat	Fruits rafraîchis
Fruit salad	mit Schaumwein	Fruits rafraîchis au cham- pagne
Fruit salad with cham- pagne	Obsttörtchen	Tartelette aux fruits
Fruit tartlet	Omelette	Omelette
Omelet(te)	mit Eis	à la norvégienne, en
Baked ice-cream, Am. baket Alaska		surprise
Omelette flambé	flambiert	flambée
Omelette with cherries	mit Kirschen	Montmorency
Jam omelet	mit Konfitüre	aux confitures
Rum omelette	mit Rum	au rhum
Soufflé omelette	soufflée	soufflée
Stephanie omelette (con- taining strawberries)	Stephanie (mit Erdbeeren gefüllt)	Stéphanie (aux fraises)
Orange cake	Orangentorte	Gâteau à l'orange
Pancakes with jam	Palatschinken	Pannequets aux confitures
Parfait	Parfait	Parfait; mousse
Petits fours	Petits fours	Petits fours
Pancake	Pfannkuchen	Pannequet
Pancake with jam	mit Konfitüre	Pannequet aux confitures
Gingerbread	Pfefferkuchen	Pain d'épice
Peach Alexandra (on vanilla ice-cream, with strawberry purée)	Pfirsich Alexandra (auf Vanilleeis, mit Erdbeerpüree)	Pêche Alexandra (sur glace vanille, avec purée de frai- ses)
Peach flambé	flambiert	flambée
Peach Cardinal (with raspberry sauce & slivered almonds)	nach Kardinalsart (mit Himbeerpüree & Mandelsplittern)	à la cardinal (avec purée de framboises et amandes effilées)



<b>SWEETS &amp; ICE CREAMS TATLILAR (GB.)</b>	<b>SÜßSPEISEN, EISSPEISEN (GER.)</b>	<b>ENTREMETS ET GLACES (F.)</b>
Peach Melba (with vanilla ice-cream & & raspberry sauce)	Melba (auf Vanilleeis mit Himbeersaft)	Melba (sur glace vanille avec purée de framboises)
Plum tart, plum flan	Pflaumenkuchen	Tarte aux prunes
Pistachio ice-cream	Pistazien-Eis	Glace aux pistaches
Profiterols au chocolat (small cream-puffs with chocolate sauce) / Ekler	Profiteroles au chocolat(Windbeutel mit Schokoladensauce)	Profiteroles au chocolat (choux à la crème nappés de sauce chocolat)
Pudding	Pudding	Pudding (pouding)
Nesselrode pudding (iced chestnut pudding)	Nesselrode (Maronen Eispudding)	Nesselrode (pudding glacé aux marrons)
Punch-cake	Punschtorte	Gâteau au punch
Cheese cake	Quarkkuchen	Gâteau au fromage blanc
Rice pudding	Reisauflauf	Gâteau au riz
Rice Trauttmansdorff (rice pudding mixed with cream, gelatine, candied fruits)	Reis Trauttmansdorf(Milchreis mit Schlagsahne & Gelatine vermischt)	Riz à l'impératrice (riz au lait additionné de crème fouetté et gélatine)
Rhubarb tartlet	Rhabarber-Törtchen	
Soufflé Rothschild (vanilla soufflé with candied fruits)	Rothschild-Auflauf(Vanilleauflauf mit kandierten Früchten)	
Iced chocolate cake	Sabayon s. Zabaglione	
Meringue Chantilly	Sacher-Torte	Sachertorte (gâteau viennois au chocolat)
Ice-cream	Sahne-Baiser	Meringue Chantilly
Cream cornet, cream roll	Sahneeis	Glace à la crème
Cream cake	Sahnerolle	Cornet à la crème
Salzburg sweet dumplings (kind of floating islands)	Sahnetorte	Gâteau à la crème
Madeira cake, pound cake	Salzburger Nockern(eine Art Schnee-Eier)	Noques à la viennoise (sorte d'œufs à la neige)
Savarin (ring-shaped yeast cake soaked in liqueur)	Sandkuchen	Quatre-quarts
with fruits	Savarin (Hefekranz, mit Likör getränkt)	Savarin

<b>SWEETS &amp; ICE CREAMS TATLILAR (GB.)</b>	<b>SÜßSPEISEN, EISSPEISEN (GER.)</b>	<b>ENTREMETS ET GLACES (F.)</b>
with whipped cream	mit Früchten	aux fruits
Layer cake	mit Schlagsahne	Chantilly
Chantilly, whipped cream	Schichttorte	Gâteau à la crème
Floating island	Schlagsahne	(Crème) chantilly(Œufs à la neige (meringues en forme d'œuf sur crème anglaise)
(meringue shells in custard sauce)	Schnee-Eier (eierförmige Meringen auf englischer Creme)	Soufflé au chocolat
Chocolate soufflé	Schokoladeauflauf	Bavarois au chocolat
Bavarian chocolate cream	Schokoladebavarois	Crème au chocolat
Chocolate cream	Schokoladencreme	Eclairs au chocolat
Chocolate éclairs	Schokoladeneclairs	Glace au chocolat
Chocolate ice-cream	Schokoladeneis	Mousse au chocolat
Chocolate mousse	Schokoladenmousse	Pudding au chocolat
Chocolate pudding	Schokoladenpudding	Sauce au chocolat
Chocolate sauce	Schokoladensauce	Gâteau au chocolat
Chocolate cake	Schokoladentorte	Truffes au chocolat
Chocolate truffles	Schokoladentrüffeln	Gâteau de la Forêt-Noire
Black Forest kirsch cake	Schwarzwälder Kirschtorte	(au kirsch)
Silvester bombe	Silvester-Eisbombe	Bombe Saint-Sylvestre
Sherbet, sorbet	Sorbet(t)	Sorbet
Gooseberry tart, gooseberry pie	Stachelbeertorte	Tarte aux groseilles à maquerreau
Saint-honoré (rich cream cake bordered with small puffs)	St.Honoré-Torte(Cremetorte mit Windbeutelchen garniert)	Saint-honoré (gâteau à la crème avec bordure) de petits choux
Millefeuille (cake of puff pastry & cream)	Tausendblätterkuchen	Millefeuille, mille-feuille
Petits fours, fancy biscuits	Topfenkuchen	Gâteau au fromage blanc
Cheese-cake	Topfenstrudel	Strudel au fromage blanc
Cheese strudel (filled with sweet curds)	Törtchen (Tortelett)	Tartelette
Tartlet	Torte	Gâteau, tarte



<b>SWEETS &amp; ICE CREAMS TATLILAR (GB.)</b>	<b>SÜßSPEISEN, EISSPEISEN (GER.)</b>	<b>ENTREMETS ET GLACES (F.)</b>
Cake, gâteau, pie	Überraschungs-Melone(mit Obstsalat gefüllt)	Melon en surprise (farci macédoine de fruits)
Surprise melon (filled with fruit salad)	Überraschungs-Omelette (Eis mit Eierschnee bedeckt & gebacken)	Omelette en surprise(glace meringuée, colorée au four)
Baked ice-cream (Ice cream covered with meringue & baked)	Überraschungs-Orangen(mit Orangeneis gefüllt)	Orangen en surprise(remplies de glace à l'orange)
Surprise oranges (filled with orange ice-cream)	Vacherin (runde Meringeböden mit aromatisierter Schlagsahne zusammengesetzt)	Vacherin Chantilly (cercles de meringue superposés, garnis de Chantilly)
Vacherin (some rounds of meringue alternated with flavoured whipped cream)	mit Eis	glacé
with ice	Vanille-Auflauf	Soufflé à la vanille
Vanilla soufflé	Vanille-Bavarois	Bavarois à la vanille
Bavarian vanilla cream	Vanille-Creme	Crème anglaise
Custard, vanilla cream	Vanille-Eis	Glace à la vanille
Vanilla ice-cream	Vanille-Sauce	Sauce anglaise
Custard sauce	Verschiedene Torten	Gâteaux variés
Variety of pies & cakes	Waffeln	Gaufres
Waffles	Weihnachtsbaumstamm	Bûche de Noël
Christmas cake / Noel keki	Weinschaum s. Zabaglione	Chou
Puff, chou	Windbeutel	(x)
Cream-puff	mit Sahne	Chou à la crème
Zabaglione, sabayon (foamy wine sauce of egg-yolk, sugar & wine)	Zabaglione (schaumige Creme aus Eigelb, Zucker & Wein)	Sabayon (crème moussueuse de jaunes d'œufs, sucre et vin)
Iced zabaglione	gefroren	Sabayon glacé
Lemon soufflé	Zitronen-Auflauf	Soufflé au citron
Lemon cream	Zitronen-Creme	Crème au citron
Lemon ice-cream	Zitronen-Eis	Glace au citron
Lemon sherbet	Zitronen-Sorbet	Sorbet au citron



SWEETS & ICE CREAMS TATLILAR (GB.)	SÜßSPEISEN, EISSPEISEN (GER.)	ENTREMETS ET GLACES (F.)
Kirsch cake	Zuger Kirschtorte	Gâteau au kirsch de Zoug
Plum dumplings	Zwetschgenknödel	Chaussons viennois aux prunes
Plum tart, plum flan	Zwetschgentorte	Tarte aux prunes, tarte aux quetsches

**ICE-CREAMS / EIS, EISCREME, EIS-SORTEN /  
GELATI / DONDURMALAR**  
desserts / sweets / nachtsiche  
Eiscremekunde / dondurma işletmeciliği



**ART.NR.**

**₺ / € / \$**

- 01 SUPER COPPA CRISTALLO**  
Macedonia, gelato, panna  
Obstsalat, Eiscreme, Schlagsahne  
Fruit-salat, ice-cream, whipped cream  
Meyve salatası, dondurma, krem şanti



- 02 EIS-CHOKOLADE**  
Cioccolato, gelato, panna  
Frischer, abgekühlter kaffee oder ein köstliches Schokoladengetränk  
- darin eine Kugel Vanille-Eiscreme & oben "versiegelt" mit einer  
Sahnehaube.  
Schokolade, Vanilleeis, Schlagsahne, 2 Hippenröllchen (rollewaffle)  
Chocholate, vanilla ice-cream, whipped cream, 2 roll vaffle-like  
Çikolata, dondurma, krem şanti, 2 rulo gofret

- 03 EIS-KAFFEE**  
Caffè, gelato, panna  
Kalter Kaffee, mit Vanilleeis & Schlagsahne,  
2 Hippenröllchen (rollewaffle)  
Cold instant Coffe, ice-cream vanilla,  
whipped cream, 2 roll vaffle-like  
Soğutulmuş sert kahve, vanıyalı dondurma, krem şanti, 2 rulo gofret



- 04 O CAPPUCCINO MIO (Ice coffee / Eiskaffee-I.)**  
"Eiskaffee auf italienisch": die süße Herbe von Cappuccino -&  
Schoko- Eiscreme, pronto garniert mit Schlagsahne & Schokoraspehn.



05

**PESCA MELBA**

Gelato, panna, pesche  
Eiscreme, Schlagsahne, Pfirsich  
Ice-cream, whipped cream, peaches  
Dondurma, krem şanti, şeftali



06

**COPPA FRAGOLE**

Fragole, panna, gelato  
Erdbeeren, Schlagsahne, Eiscreme  
Strawberries, whipped cream, ice-cream  
Çilek, krem şanti, dondurma



07

**COPPA ANANAS**

Ananas, gelato, panna  
Ananas, Eiscreme, Schlagsahne  
Ananas, ice-cream, whipped cream  
Ananas, dondurma, krem şanti



08

**COPPA DELL'AMICIZIA**

Macedonia, gelato, panna  
Obstsalat, Eiscreme, Schlagsahne  
Fruit salad, ice-cream, whipped cream  
Meyve salatası, dondurma, krem şanti



09

**COPPA CRISTALLO**

Macedonia, gelato, panna  
Obstsalat, Eis, Schlagsahne  
Fruit salad, ice-cream, whipped cream  
Meyve salatası, dondurma, krem şanti



10

**COPPA FRUTTI DI BOSCO**

Gelato, frutti di bosco, panna  
Eis, Waldfrüchte, Schlagsahne  
Ice-cream, wild berries, whipped cream  
Dondurma, yabani çilekler, krem şanti



11

**BANANEN SPLIT / BANANA BOAT**

Banana, gelato, panna  
Banane, Eis, Schlagsahne (Eine Banane, der Länge nach halbiert, darauf 3 Kugeln Vanille-Eiscreme, garniert mit Schoko-Sauce, Mandelsplittern & Sahnehäubchen  
Banana, ice-cream, whipped cream  
Muz, dondurma, krem şanti

12

**COPPA BUTTERFLY**

Gelato, amarene, panna  
Eis, Sauerkirschen, Schlagsahne  
Ice-cream, sour cherries, whipped cream  
Dondurma, vişne, krem şanti



- 13 **COPPA CON PANNA**  
Gelato misto, panna  
Gemischtes-Eis, Schlagsahne  
Mixed ice-cream, sour cherries, whipped cream  
Karışık dondurma, vişne, krem şanti
- 14 **AFFOGATO**  
Gelato, amarena o liquore  
Eis, Kirschen oder Likör  
Ice-cream, sour cherries or liqueurs  
Dondurma, vişne veya likörler
- 15 **AFFOGATO ALLO YOGURT**  
Gelato allo yogurt, yogurt  
Yogurt-Eiscreme, Yogurt  
Yogurt-ice-cream, yogurt  
Yoğurtlu dondurma, yoğurt
- 16 **COPPA NORMALE**  
Gelato misto  
Gemischtes Eiscreme  
Mixed ice-cream  
Karışık dondurma
- 17 **COPPA AZZURRA**  
Gelato, panna, albicocche  
Eis, Schlagsahne, Aprikose  
Ice-cream, whipped cream, apricots.  
Dondurma, krem şanti, kayısı
- 18 **FRAPPÉS**  
Mokka, Schokolade, Erdbeer, Amarenakirsche,  
Banane, Orange, Zitrone.  
Mocca, Chocolate, strawberry, Ameranacherries,  
Banana, Orange, Citron  
Mokka, çikolata, çilek, amerana kirazı, muz, portakal, limon
- 19 **FRUCHTBECHER**  
Mit Früchten der Saison, Vanilleis & Sahne  
With fruit in season, ice cream vanilla & cream  
sezon meyveleri & krem şanti
- 20 **SPAGHETTI-EIS**  
Vanilleis mit Erdbeersoße & weißer geraspelter Schokolade  
Vanilla ice-cream with strawberrie sauce & white to rasp chocolate  
Çilek soslu vanilyalı dondurma & rendelenmiş beyaz çikolata  
(kasap kıyma makinelerine benzer el aleti ile dondurma çekilir.)



- 21 AMERANA-BECHER**  
Mit gemischtem Milcheis (vanille ice-cream),  
Amarenakirschen & sahn  
with mixed milk ice-cream, amerana cherries & cream  
karişik sütlü dondurma, amerana kirazi & krem şanti.
- 22 ERDBEERBECHER / STRAWBERRY CUP**  
mit frischen erdbeeren & Maraschino (in Saison)  
with fresh strawberry & maraschino sour cherry liqueur (in season)  
taze çilek & vişne likörü (sezonunda)
- 23 HAWAII-BECHER**  
mit vanille & Stracciatellais (Langnese Spc.), Ananas & Sahne  
with vanilla & Stracciatella ice cream, ananas & cream  
vanilyalı dondurma, Stracciatella dondurma, ananas & k.şanti.
- 24 ICE-CREAM WITH ALCOHOLIC**  
Eiscreme mit alkohol / Alkollü dondurma
- 25 ICE-CREAM WITH FLAMBÉ**  
Eiscreme mit flambiért / alevli (flambé) dondurma
- 26 EIERLIKÖR-BECHER**  
mit Vanilleeis & Sahne, Eierlikör  
with vanilla ice-cream & cream, Eggliqueur  
vanilyalı dondurma & krem şanti, yumurta likörü
- 27 CALIFORNIA-BECHER**  
Eiscreme mit Pflaumen in Alkohol  
Ice-cream with plum (prune) in alcohol  
Erikli dondurma (alkollü)
- 28 APRIKOT-BECHER**  
mit Vanille & Nußeis, 1/2 aprikose  
with vanilla & nut ice-cream, 1/2 apricot  
vanilyalı & fıstıklı dondurma, 1/2 kayısı
- 29 EIS-BOMMI**  
1 kugel sahnigem Vanille-Eis, 4 cl. Bommerlunder  
(% 40° spirits / spiritouse), & prickelnder Zitronenlimonade  
zubereitet, 2 strohhalme, 1 tranche zitrone  
1 ball cream vanilla ice-cream, 4 cl. Bommerlunder (% 40°  
spirits / spiritouse), lemonade, 2 straws, 1 tranche lemon  
1 top vanilyalı dondurma (krem şantili), 4 cl. Bommerlunder  
(% 40° spirits / spiritouse), limonata, 2 pipette,  
1 tranche limon





- 30 MARASCHINO BECHER**  
mit gemischtem Eiscreme, Likör & Sahne  
with mixed ice-cream, liqueur & cream  
karişik dondurma, likör & krem şanti
- 31 CHERRY-BECHER / CUP**  
Eiscreme mit kirsch  
Ice-cream with cherry  
kirazlı dondurma.
- 32 BABA-BECHER**  
mit Vanilleeis, zartem Hefeteiggebäck in Alkohol  
vanilla ice-cream, in alcohol  
vanilyalı dondurma, ince yumuşak mayalı hamur (alkollü)
- 33 GEMISCHTES EIS**  
Ein bunter Becher mit den beliebtesten Eiscreme &  
Fruchteisorten nach Wahl, mit oder ohne Sahne.
- 34 FRÜCHTEBECHER**  
Die beliebtesten Eissorten Ihrer Gäste, angerichtet mit  
einem Früchte-Cocktail (frisch oder als conserve) & 1  
Waffel (waffle-like / gofret)
- 35 SCHWARZWALD-BECHER**  
Vanille & Schokoladen-Eiscreme mit Kirschen,  
einem Schuß Kirschwasser (spiritousen / spirits), Sahnehaube,  
etwas geraspelter Schokolade & 1 Waffel.
- 36 PFIRSICH MELBA**  
Vanille-Eiscreme & 1/2 Pfirsich-Hälfte auf Himbeermark (raspberry /  
ahududu) mit einem Sahnehäubchen.  
(Ahududu şurubunun üzerine vanilyalı dondurma, 1/2 şeftali,  
krem şanti, tekrar ahududu şurubu)
- 37 EISBECHER "WALNUS"**  
Premium-Eiscreme "Walnuß" mit vielen kandierten  
Walnuß-Stückchen, abgerundet mit Vanille-Eiscreme, Sahne & Waffel  
(waffle-like/gofret)
- 38 COPPA BELLA STRACCIATELLA**  
Eine der beliebtesten italienischen Eissorten, "Stracciatella"  
(Langnese spc.) & Schokoladen-Eiscreme, garniert mit Früchten &  
Eisgebäck (1 Hippenroll, rollwaffle-like / rulo gofret)  
İtalya'nın sevilen dondurma çeşitlerinden "Stracciatella"  
Langnese spc. & çikolatalı dondurma, meyvelerle süslenmiştir  
& rulo gofret..



- 39 EIS & HEISS MIT HIMBEEREN**  
**ice-cream & hot with raspberries**  
 Vanille-Eiscreme mit heißen Himbeeren in eigenem Saft  
 & obendrauf ein Sahnekrönchen.  
 Serin günler için: Ahududu & şurubunun üzerine vanilyalı  
 dondurma, üzerine krem şanti.
- 40 EIS & HEISS MIT SAUERKIRSCHEN**  
**ice-cream & hot with sour cherries**  
 Jahreszeit: zartschmelzendes Vanille-Eis mit Sauerkirschen,  
 erhitzt im eigenen Saft.  
 Vanilya dondurması & kendi şurubunda ısıtılmış vişne.
- 41 KINDERBECHER KUNTERBUNT**  
 2 Sorten Eiscreme (Vanille & Erdbeer) mit Sahne, bunten Zuckerstreuseln  
 & Schoko-Linsen. (draje, renkli mercimek çikolata şekerleme) İki çeşit  
 dondurma (vanilya & çilek) krem şanti
- 42 COPPA CAPRI**  
 mit beliebig gemischten Fruchteis-Sorten.  
 İstenilen çeşitte meyveli dondurma
- 43 SCHLEMMERBECHER COPPA GRANDE**  
 Ein Schlemmerbecher mit gemischten Eiscreme Sorten wie  
 B. Stracciatella, Walnuß, Schokolade & Vanille, garniert mit  
 Schlagsahne, Eierlikör, schokofflocken & 1 Fächerwaffel.  
 Değişik dondurma çeşitleri, stracciatella, fıncıklı, çikolatalı &  
 vanilyalı dondurma, krem şanti ile süslenmiş, yumurta likörü, çikolata  
 taneleri & yelpaze gofret.
- 44 COUPE DÄNEMARK**  
 Cremiges Vanille-Eis, großzügig übergossen mit kalter oder warmer  
 Schoko-Sauce, garniert mit Sahne & 1 Herzwaffel (1 kalp gofret)  
 Vanilyalı dondurma, üzerine soğuk veya sıcak çikolata sosu, krem şanti &  
 1 kalp gofreti.
- 45 ERDBEER-BECHER**  
 Vanille Eiscreme mit frischen Erdbeeren, Sahnekrönchen &  
 einer Eiswaffel. (1 dondurma gofreti), Vanilyalı dondurma,  
 taze çilek, krem şanti & 1 dondurma gofreti.
- 46 BIRNE HÉLÈNE**  
 Vanille-Eiscreme mit einer halbierten Kompottbirne, möglichst  
 heißer schokoladensauce Schlagsahne & Waffelkeks. Vanilyalı  
 dondurma ile armut, sıcak çikolata sosu, krem şanti.
- 47 SCHLEMMERBECHER ROMANTICA**  
 Cremiges Erdbeer & Vanille-Eis mit einem Fruchtcocktail (frisch oder als Kon-  
 serve), Sahne & Erdbeersauce. Çilekli & vanilyalı dondurma 1 kokteyl kirazı,  
 krem şanti, çilekli sos.



- 48 **SANFTER ENGEL (Ice-cream drinks)**  
 Orangensaft (auf Gästewunsch leicht beschwipst mit einem Schuß Rum)  
 mit einer Kugel Vanille-Eiscreme. Portakal suyu  
 (müşterinizin isteği üzerine biraz rum) bir top vanilyalı dondurma.
- 49 **SHISH ICE (Maraş Special / TUR.)**  
 Şiş dondurma / Ice-cream with spit  
 Eiscreme am Spieß
- 50 **SYMPHONIE IN NUSS**  
 Ein, „nussikalisches“ Erlebnis von cremigem Pistazien -&  
 Walnuß-Eiscreme. Dazu ein Tupfer Sahne & 1 Waffel.  
 (1 gofret / waffle-like.)  
 Kremalı, çam fıstık & cevizli dondurma, krem şanti & 1 gofret.
- 51 **EISBECHER RUMTOPF**  
 Ein Wintermärchen: eine Kelle Rumtopf-Früchte-darauf zartschmelzende  
 Rumtopf-Eiscreme mit vielen Früchten-dekoriert mit Sahne & Waffel.  
 Nugat & Krokant dondurma, krem şanti, gofret, yumurta likörü.
- 52 **FLORENTINER NÄCHTE**  
 Nougat -& Krokant- Eiscreme, garniert mit Sahne, Waffel &  
 einem Schuß Eierlikör, 1 waffle-like / 1 gofret.
- 53 **COPPA CIGNO**  
 Gelato, panna, melone, kiwi  
 Eiscreme, Schlagsahne, Melon, Kiwi  
 Ice-cream, whipped cream, melon, kiwi  
 Dondurma, krem şanti, kavun, kiwi,  
 (Gelato, panna, kavun, kiwi, dondurma, krem şanti).
- 54 **EISBECHER, CHAMPAGNER-TRÜFFEL**  
 Der Eisbecher für hohe Ansprüche mit den Premium-Eiscremes  
 „Champagner-Trüffel“ & „Bourbon-Vanille“, garniert mit  
 Schlagsahne, Schokoladensauce & einer Fächerwaffel.  
 (yelpaze gofret / fan waffle-like)  
 Şampanyalı pralin & Bourbon-dondurma, krem şanti, çikolata  
 sosu & 1 yelpaze gofret.
- 55 **EISBECHER EIERLIKÖR-KIRSCH**  
 Saftige Kirschen in zartschmelzender Eierlikör-Eiscreme, garniert mit  
 Kirschen (heiß oder kalt), Sahnehäubchen, Schokoladenraspeln & einer  
 Fächerwaffel. (yelpaze gofret / fan waffle-like)  
 Kiraz, yumurta likörlü dondurma, kiraz ile süsleyin. (sıcak veya soğuk)  
 krem şanti, rendelenmiş çikolata, 1 yelpaze gofret.



- 56 EISBECHER WEISSE SCHOKOLADE**  
Eine totale Schokoladen-Schlemmerei mit den Premium-Eiscremes aus weißer & dunkler Schokolade. Als feiner Kontrapunkt eine Garnierung aus Mandarinen-Filets. Obendrauf ein Hippenröllchen. (2 ring-roll waffle) Beyaz & koyu çikolatalı dondurma, dilim mandalina ile süsleyin, üzerine 1 rulo gofret.
- 57 EISBECHER PFIRSICH**  
Fruchteiscreme mit Pfirsichstückchen & Pfirsich-Cocktail, garniert mit Früchten & Sahne. Şeftalili dondurma, şeftali parçacıkları & şeftali kokteyli, meyvelerle süsleyin & krem şanti.
- 58 EISBECHER KIRSCH**  
Feinste Kirsch-Frucht-eiscreme mit saftigen Kirschen, garniert mit Kirschen, etwas Sahne & einer Fächerwaffel. Kirazlı dondurma, kiraz ile süsleyin, krem şantili 1 yelpaze gofret.
- 59 EISBECHER MALAGAÑA**  
Malaga-Eiscreme mit echtem Malagawein & Rumsultaninen, begleitet von einer Kugel Vanille-Eiscreme & garniert mit Rum-Rosinen & 1 Eiswaffel. Hakiki Malaga şarabından yapılmış Malaga-dondurma, rumlu kuru üzüm ile süsleyin & 1 dondurma gofreti.
- 60 EISBECHER TIRAMISÙ**  
Tiramisù -& Vanille-Eiscreme mit einem Sahnetupfer. Tiramisu & vanilyalı dondurma, krem şanti.
- 61 EISBECHER KAFFEE**  
Kaffee-Eiscreme mit vielen Stückchen zarter Kaffee-Schokolade, abgerundet mit einer Kugel Vanille-Eiscreme & garniert mit Sahne & Schokosauce. Kahveli, çikolatalı dondurma, 1 top vanilyalı dondurma & krem şanti çikolatalı sos.
- 62 EISBECHER JOGHURT-WALDBEEREN**  
Joghurt-Eiscreme mit Waldbeeren-Cocktail & Vanille-Eiscreme, garniert mit Beerenfrüchten & einem Joghurt-Häubchen. Yoğurtlu dondurma, orman çilekli kokteyl & vanilyalı dondurma, orman çilekleri, ahududu v.s., biraz yoğurt ile süsleyin.
- 63 COPPA ORANGE-MILANO**  
Je eine kugel orangen-fruchteis mit Bitterlikör, Erdbeer-Fruchteis & Vanille-Eiscreme, umlegt mit Mandarinen-Filets, Sahne & Hippenröllchen (2 rulo gofret, 2 roll waffle-like), 1 top portakallı bitter likörlü dondurma, çilekli dondurma & vanilyalı dondurma, dilimlenmiş mandalina, krem şanti & rulo gofret.



- 64 **COPPA ZABAIONE**  
Zabaione -& Amaretto-Eiscreme mit einer Sahne-Eierlikör-Garnierung, überstret mit Krokant-Streusel.  
Zabainne & Amaretto dondurması, krem şanti, yumurta likörü, rendelenmiş krokant.
- 65 **EISBECHER MANDEL**  
Ein Potpourri aus Mandel-, Schokoladen- & Vanille-Eiscreme auf Sauerkirschen, garniert mit einem Sahnehäubchen & Kirschsauce.  
Vişne üzerine badem, çikolatalı, vanilyalı dondurma, krem şanti, vişne sosu.
- 66 **COPPA ITALIA**  
Eiscreme Vanille-Kiwi, garniert mit südlichen Früchten.  
Vanilyalı-kivili dondurma, güney meyveleri ile süsleyin.
- 67 **EISBECHER BOTTERMELK FRESH**  
Ein Eisbecher mit bottermelk-fresh-Eiscreme nach Wahl, garniert mit Limonen- oder zitronenscheibe.  
1 dondurma kupasına bottermelk-fresh dondurması (tercihe göre dekor limon veya limetten dilimleri).
- 68 **COUPE MOZART**  
Çam fıstık (pistachios) & çilek (strawberries / erdbeere), Mozart Çikolata - Nugat Liqueur, kiraz & badem parçaları (almonds / mandels), rulo gofret



## ICE-CREAM FRAPPÉS

Ice-Cream Frappés werden mit Speiseeis im Blender zubereitet. 2 Kugeln (balls / top) Fruchteis, 1 Barlöffel Zucker, 4 cl. Milch & 4 cl. der gewünschten Spirituose werden gemischt. Das Glacé wird in einem Tumbler mit 4 cl. der gewünschten Spirituose, viel Eis, Löffel & Trinkhalm serviert. Dazu reicht man eine Karaffe Wasser.

Ice-Cream Frappés: Bunlar dondurma ile blenderde hazırlanır. 2 top (kugeln / balls) meyveli dondurma, 1 bar kaşığı şeker, 4 cl. süt & 4 cl. istenilen ispirotolu içki (spirits / spiritouse) karıştırılır.

Glacé: Bir Tumbler bardağına 4 cl. istenilen ispirotolu içki (spirits / spiritouse), çok buz, kaşık, pipet & su ile servis edilir.



## EISCREME-SHAKES & DRINKS (eisgetränke)

### 01 EISSHAKE "ST.JOHN"



Ein erdbeeriger Sommerflip, alkoholfrei gemixt aus Vollmilch, einer Kugel Erdbeer-Eiscreme. decor: am cocktailspieß 2 x 1/2 frischen Erdbeeren (strawberries / çilek).

### 02 EISSHAKE "ST.THOMAS"



Ein alkoholfreier Sommershake aus herrlich fruchtigem Ananas-Eis mit Orangensaft (juice / suyu) & Kokosnuß-Creme. decor: am cocktailspieß 1/2 tranche orange (portakal), 1/4 kiwi, 1 cocktailcherry (cocktailkirsche / kokteyl kiraz).

### 03 EISDRINK "SAN JOSÉ"



Ein exotischer Sommerdrink, gemixt aus Ananassaft mit Ananas-Eis & abgestimmt mit Kokosnuß-Likör. decor: am cocktailspieß 1/2 tranche ananas (pineapple), 1 cocktailcherry (cocktailkirsche / kokteyl kiraz).

### 04 GRENADINE SHAKE



2 cl. Grenadine, 4 bar sp. lemon juice (saft/suyu), 1/8 lt. süt / milch / milk, 1 pipette / straw / strohhalm

## Langnese / Algida ice-cream / eiscreme / dondurma-special



### **Vanilla / Vanille / Vanilya**

Chocolate / Schokolade / Çikolata (brown / braun / kahverengi)  
(Eiscreme mit Schoko-Stückchen, çikolata parçalı dondurma)



### **Chocolate / Schokolade / Çikolata (white / weiß / beyaz)**

(Eiscreme mit Stückchen weißer Schokolade / rendelenmiş beyaz çikolatalı dondurma)



### **Strawberries / Erdbeere / Çilek**

(Fruchteiscreme mit Erdbeer-Stückchen, çilekli, meyveli dondurma)



### **Walnut / Walnuß / Ceviz**

(Eiscreme mit kandierten Walnüssen, ceviz şekerlemeli dondurma)



### **Pistachio / Pistazie / Çam Fıstığı**

(Eiscreme mit Pistazien-Stückchen, çam fıstığı parçalı dondurma)



### **Stracciatella**

Citron, Lemon / Zitronen / Limon



### **Almond / Mandel / Badem**

(Eiscreme mit schokolierten Mandel-Stückchen, çikolatalı, bademli dondurma)



### **Champagner-Trüffel**

(Praliné-Eiscreme mit Champagner-Trüffeln & Schoko-Sauce, şampanyalı dondurma, pralin & çikolata sos)



### **Coffee / Kaffee / Kahve**

(Eiscreme mit Mokka Schokoladen Stückchen, kahve & çikolata parçalı dondurma)



### **Caramel / Caramel / Karamela**



(Caramel Eiscreme mit Toffee-Stückchen)



**Pineapple / Ananas**

(Fruchteis mit Ananas-Stückchen, ananas parçalı, meyveli dondurma)



**Cherry / Kirsche / Kiraz**

(Fruchteiscreme mit saftigen Kirschen, kiraz sulu, meyveli dondurma)



**Peach / Pfirsich / şeftali**

(Fruchteiscreme mit Pfirsich-Stückchen & Pfirsich-Sauce, şeftali parçalı, meyveli dondurma & şeftali sosu)



**Pear / Birne / Armut**

(Fruchteiscreme mit Birnen-Stückchen, armut parçalı, meyveli dondurma)



**Yoghurt Wildfruit / Yoghurt Waldfrucht /**

**Yoghurt Yabani, Orman Meyveleri**

(Joghurt- Eiscreme mit Himbeeren & Heidelbeeren / Raspberry / Ahududu, ağaç çilekli, yoğurtlu dondurma)



**Currant / Johannisbeeren / Frenk Üzüümü / Cassia**

(Fruchteis mit schwarzen Johannisbeeren, siyah frenk üzümü meyveli dondurma)



**Diet-Cocktail / Diät-Cocktail / Diet Kokteyl**

(Eiscreme Vanille-Geschmack mit Erdbeer-Sauce, çilek soslu, vanilya tadında dondurma)



**Cinnamon / Zimt / Tarçın / Pflümlü**

(Zimt- Eiscreme mit Pflaumenstückchen in Armagnac, Armagnac brendili, tarçınlı, erik parçalı dondurma)



**Malaga**

(Malaga-Eiscreme mit Rum-Sultanien)



**Bourbon-Vanille**

(Vanille-Eiscreme mit echter Bourbon-Vanille, vanilyalı dondurmali Bourbon whiskey)



**Rumtopf**

(Eiscreme mit Rumtopf- Früchten)



**Advokat-Kirsch / Yumurta Likörü & Kiraz**

(Eierlikör- Eiscreme mit Kirsch-Stückchen, kiraz parçalı dondurma & yumurta likörü)



**Tiramisù**

(Eiscreme mit Biskuit- Stückchen & Mokka-Sauce, bisküvi parçalı & kahve soslu dondurma)



## Ice-cream drinks / eiscreme drinks / dondurmali içkiler

### 01 New York Fresh



Grapefruit juice (saft/suyu), vodka & 2 ball / Kugeln / top ice-cream / Eiscreme / dondurma (istek üzerine alkolsüz). Decor: 1/2 tranche orange, 1 pipette / straw / strohhalm.

### 02 Heavy Fresh



Marajuca juice (saft/suyu), cin, curaçao blue liqueu & 2 ball / Kugeln / top ice-cream / Eiscreme / dondurma (istek üzerine alkolsüz). Decor: Tranche lemon, 1 pipette / straw / strohhalm, casis / johannisbeer frucht / salkım frenk üzümü.

### 03 Sanfter Engel



Vanilla-ice-cream in orange juice / vanille-Eiscreme in Orangensaft / portakal suyu içinde vanilyalı dondurma, 1 pipette / straw.

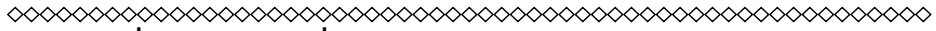

## ice-cream glass, cup terminology

## eiscreme glas, becher terminologie

## dondurma bardak, kupa terminoloji



### Art.Nr.

01 (36 480)

Ice-cream goblet,  
cup-lilie

Eiscremekelch Lilie

Dondurmakelch (ayaklı  
kupa, çanak)

ø : 7 cm.

h. : 20 cm.

cap.: 40 cl. / 400 gr./ml.



### Art.Nr.

02 (36 439)

Ice-cream chocolate cup

Eis-Schoko-Becher

Dondurma kupası,  
kadehi

ø : 6.5 cm.

h. : 15.5 cm.

cap.: 18 cl. / 180 gr./ml.



### Art.Nr.

03 (38 717)

Ice-cream goblet, cup

Eiscremekelch-Flora

Dondurma kelch (ayaklı  
kupa, çanak)

ø : 13 cm.

h. : 15 cm.

cap.: 35 cl. / 350 gr. / ml.

### Art.Nr.

04- (36 110)

Ice-cream bowl

Eiscremeschale Gala

Gala Dondurma schale  
(kâse, çanak)

ø : 12.5 cm.

h. : 12.5 cm.

cap.: 32 cl. / 320 gr./ml.



### Art.Nr.

05 (37 168)

Ice-cream cup, goblet  
(big)

Eispokal Bonaparte  
groß

Dondurma kupası  
(büyük)

ø : 13 cm.

h. : 12.5 cm.

cap.: 35 cl. / 350 gr./ml.







Art.Nr.  
06 (36 404)  
Ice-cream cup, goblet (little)  
Eispokal Bonaparte klein  
Dondurma kupası (küçük)  
ø : 11 cm.  
h. : 12 cm.  
cap.: 22.5 cl. / 225 gr./ml.



Art.Nr.  
07- (38 008)  
Actionscup (stocksbar)  
Aktionsbecher (stapelbar)  
Etkili kupa (istiflenebilir)  
ø : 11 cm.  
h. : 8 cm.  
cap.: 30 cl. / 300 gr./ml.



Art.Nr.  
08- (38 059)  
Banana-Split, boat-  
bowl  
Bananen-Split-  
Schale  
Muz schale, bot,  
kayık, kase, çanak  
Länge 21 cm.  
Breite: 10 cm.



Art.Nr.  
09 (36390)  
Ice-cream glass petit  
Eiscreme glas Petit  
Dondurma bardağı petit  
ø : 10 cm.  
h. : 7 cm.  
cap.: 20 cl. / 200 gr./ml.

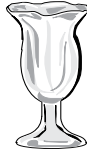

Art.Nr.  
10 (38 024)  
Ice-cream cup, goblet classic  
Eiscremekelch classic  
Dondurma kupası klasik  
ø : 10 cm.  
h. : 15 cm.  
cap.: 19 cl. / 190 gr./ml.



Art.Nr.  
11 (39 675)  
Ice-cream cup  
Eis-café-Becher  
Dondurma kupası  
ø : 8 cm.  
h. : 13 cm.  
cap.: 23 cl. / 230 gr./  
ml.



Art.Nr.  
12 (37 966)  
Ice-cream glass tutti  
frutti  
Eiscreme glas tutti  
frutti  
Dondurma bardağı  
tutti frutti  
ø : 12 cm.  
h. : 10 cm.  
cap.: 31 cl. / 310 gr./  
ml.



Art.Nr.  
13 (36 013)  
Ice-cream glass-Grandioso  
Eiscreme glas-Grandioso  
Dondurma bardağı-  
Grandioso  
ø : 10.5 cm.  
h. : 10 cm.  
cap.: 12.5 cl. / 125 gr./  
ml.



Art.Nr.  
14 (38 016)  
Amerana-Glass /  
glas / bardağı  
ø : 9 cm.  
h. : 10 cm.  
cap.: 12.5 cl. / 125  
gr./ml.





Art.Nr.  
15 (38 164)  
Gino Ginelli-  
Promotion  
Glass / Glas  
Gino Ginelli-  
promosyon bardađı  
ø : 10 cm.  
h. : 12,5 cm.  
cap.: 18 cl. / 180 gr./  
ml.



Art.Nr.  
16 (36 790)  
Ice-cream glass Carte  
D'or  
Eisglas Carte D'or  
Carte D'or dondurma  
bardađı  
ø : 11,5 cm.  
h. : 13 cm.  
cap.: 50 cl. / 500 gr./ml.



Art.Nr.  
17 (36 005)  
Astoria-Cup  
Astoria-Schale  
Astoria-kupası, cup  
ø : 17 cm.  
h. : 10 cm.



Art.Nr.  
18 (39 918)  
Ice-cream gondalla Gino Ginelli  
(porcelain or glass)  
Eiscremegondel Gino Ginelli  
(Porzellan oder glas)  
Dondurma gondol Gino Ginelli  
(porselen veya cam)

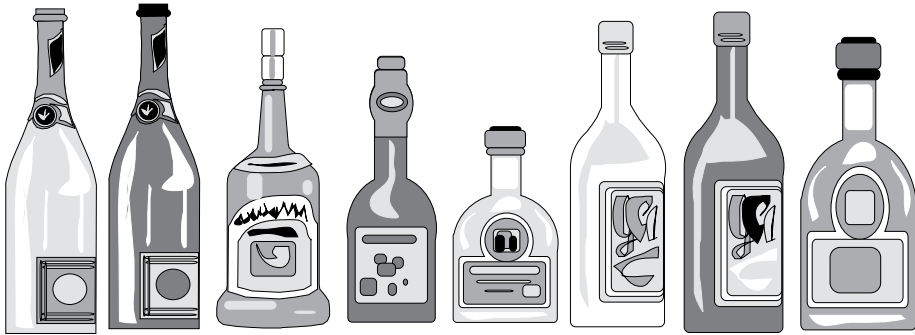

# master menu guide / führer / rehber

art. nr.

₺ / € / \$

## LUNCH & DINNER MENU (11.30 am - 23.00 pm)

- 01- SANDWICHES ham, chicken, white or kashar cheese  
soğuk-cold
- 02- CLUB SANDWICH
- 03- TOASTS with kashar cheese, sausages, salami, mixed-  
kaşarlı, sucuklu, salamlı, karışık
- 04- HAMBURGER with chips
- 05- CHEESEBURGER



### STARTERS

- 06- ORDÖVR TABAĞI / HORS D'ŒUVRES PLATE
- 07- PEYNİR TABAĞI / CHEESE PLATER
- 08- POMMES - FRITES / CHIPS / patates / fried potatoes
- 09- SIGARA BÖREĞİ / CHEESE PASTRY CIGAR
- 10- AVCI BÖREĞİ / hunter pastry cigar / Jäger pa'stete zigarre
- 11- KARIŞIK OMLET / MIXED OMLETTE



### MIXED MEZE'S/entrées/starters

- 12- RUSSIAN SALAD - ANTEP EZME - HAYDARI
- 13- KARIŞIK SALATA / seasonal MIXED SALAD  
"çoban salata - shepherd's salad"
- 14- SOĞUK ET TABAĞI / ASSORTED COLD MEAT PLATER
- 15- YOĞURT / YOGHURT (Joghurt-yaourt-yogourt-iogurt-yogur)
- 16- CACİK, CACİKİ "cucumber with yoghurt"

### BARBECUE GRILLS / IZGARALAR (main course haupgerichte)

- 17- KÖFTE / MEATBALLS / FRIKADELEN
- 18- KARIŞIK IZGARA / MIXED GRILL
- 19- ŞİŞ KEBAP / SHISH KEBAB "çöp şiş"
- 20- PİRZOLA / RIBS OF BEEF "cotlet"



## SOTELER / SAUTES / GERÖSTED

- 21- ET SOTE / SAUTÉ MEAT "turkish goulash"  
22- MANTARLI ET SOTE / SAUTÉ'D MEAT WITH MUSHROOMS  
23- ÇOBAN KAVURMA / SHEPHERD'S ROAST  
"lamb stew / meat roast with sauce"  
24- BALIK / FISH / FISCH (extras)  
seafood / meeresfrüchte / fruits de mer / deniz ürünleri



## TATLILAR / DESSERTS / sweets / nachtische

(süßspeisen / piattoforte / plato fuerte / soğuklar / patisserie)

- 25- MEYVE TABAĞI / SEASONAL FRUIT PLATE  
26- BAL, KAYMAK, MUZ / BANANAS  
WITH HONEY & FRESH CREAM "in season" aphrodisiac  
27- KABAK ŞEKERİ / PUMPKIN SUGAR / KURBIS ZUCKER  
"Barantico spc." aphrodisiac / afrodisyak özellikli  
28- KOKTEYL KİRAZI / COCKTAIL CHERRY "green, red"  
29- MEYVE ŞEKERİ / FRUIT SUGAR / OBST ZUCKER  
30- DRAJE ÇİKOLATA / CHOCOLATE DRAGE "mixed" 'kadehte  
31- MEYVE SALATASI / FRUIT SALAD "non alcoholic" - "season" 'kadehte  
32- ALKOLLÜ MEYVE SALATASI / FRUIT SALAD with alcohol 'kadehte  
33- • KAŞIK AYVA / QUINCE BALLS "plain" (in season) - sade/pure/pur 'kadehte  
34- KAŞIK ELMA / APPLE BALLS "plain" (in season) - sade/pure/pur 'kadehte  
35- • SOLGUN GÜNEŞ / QUINCE BALLS "in white wine, lemon 'kadehte  
juice, salt - b.şarap, limon suyu, tuz." (in season - sezonunda)  
36- • KIZGIN AYŞE / APPLE BALLS "in season - sezonunda" 'kadehte  
"in white wine, white pepper, salt - b.şarap, beyaz biber, tuz."  
37- KARIŞIK ÇEREZ / ASSORTED NUTS / GEMISCHTE NÜBE  
38- ANTEP FISTIK / PISTACHIOS  
39- BADEM / ALMONDS / MANDELS  
40- PANÇO & RUFFLES  
41- YEŞİL ZEYTİN / GREEN OLIVES  
sade, biberli, bademli / with almonds, red pepper or pur.  
42- HAVUÇ, LİMON SUYU, TUZ /  
CARROT, LEMON JUICE, SALT "in season - sezonunda"



## BİRALAR / BEERS / BIERE 3.5°-5°

43-	küçük / small	0.33 l. /33 cl./330 gr./ml.
44-	medium	0.4 l./40 cl./400 gr./ml.
45-	büyük / large	0.5 l./50 cl. / 500 gr./ml.
46-	mega	1 l./1000 gr./ml.
47-	bottled / flaschen / şişe	30cl./300 gr./ml.

## BEER COCKTAILS / biralı kokteyller

48-	• RADLER / SHANDY	0.4 l. / 40 cl. / 400 gr.
		0,2 l. beer, 0,2 l. lemonade (limonade / limonata / citronnade / limonada)
49-	BEER PUNCH	
		2 cl. brandy, 2 cl. sherry, 2 cl. lemon juice, 1 bar sp. grenadine syrup, beer fill up (to fill (up)/füllen (auf)/doldurunuz (üzerine) /remplir/riempire), spiral lemon
50-	WISA GLORIA	
		1 cl. * grenadine syrup, beer fill up (to fill (up)/füllen (auf) / doldurunuz remplir / riempire), spiral lemon
51-	TAWARISH 4 cl.	
		vodka, 2 bar sp. lemon juice, beer fill up (to fill (up) / füllen (auf) / doldurunuz / (üzerine) remplir / riempire), spiral lemon
52-	CHURCHILL	
		2.5 - 3 cl. *campari "bitter", beer fill up (to fill (up)/füllen (auf) / doldurunuz (üzerine) / remplir / riempire), spiral lemon

## ŞARAPLAR / WINES / WEINE (local) 18°-22° "dry, medium, sweet"

53-	beyaz / white	0.35 cl.
54-	beyaz / white	0.70 cl.
55-	beyaz / white	0.2 l.
56-	roze / rosé	0.35 cl.
57-	roze / rosé	0.70 cl.
58-	roze / rosé by glass / glas / kadeh	0.2 l.
59-	kırmızı / red	0.35 cl.
60-	kırmızı / red	0.70 cl.
61-	kırmızı / red by glass / glas / kadeh	0.2 l.
62-	WINE DE - LUXE (local)	0.35 cl.
63-	WINE DE - LUXE (local)	0.70 cl.
64-	SPARKLING WINE / CHAMPAIN (local) "aperitifs"	0.70 cl.



## SPIRITS "aperitifs", LIQUEURS "digestifs"

& BITTERS (import/ithal) 16°-24°-43°-45°-47°

- 69- İTHAL İÇKİLER /IMPORTED DRINKS 4 cl.  
70- DE - LUXE DRINKS 4 cl.  
71- SPIRITS "aperitifs" & LIQUEURS "digestifs" (local) 40°-45° 4 cl.  
72- SPIRITS "aperitifs & digestifs - yemek öncesi & sonrası içilen ispirotolu içkiler.(import)

## WHISKY / WHISKEY / VİSKİ

before & after dinners / digestifs / (biradan damıtılmış, destille edilmiş içkiler)

- 73- SCOTCH WHISKY single Malt / pur / pure / sade  
(non on the rocks) özelliği arpa / pınar suyu, peat  
(kurutulmuş turba yakıtı kokulu, bu koku dünyada tek  
iskoç viskilere özgüdür.)  
74- SCOTCH WHISKY blended / harmanlı  
75- BOURBON WHISKEY /American whiskey malt & blended / harmanlı  
(mısır, çavdar, buğday & mayalanmış arpadan, meşe fiçisinde dinlendirilmiş,  
odun kömürü kokulu)  
76- IRISH WHISKEY / Eire blended / harmanlı  
(mısır, çavdar, buğday, yulaf & mayalanmış arpa, meşe fiçisinde  
dinlendirilmiş), duman tatsız, 3 kez damıtılmış, pure / pur / sade - buzsuz içilir.  
77- CANADIAN WHISKY blended / harmanlı  
(çavdar & mısırdan damıtılmış)  
78- ANKARA VİSKİ / Turkish whiskey blended / harmanlı  
79- SANTORY / Japan whiskey blended / harmanlı (peat /  
kurutulmuş turba yakıtı kokusuz, kaliteli viski)

## COCKTAILS (import/ithal) "these mixtures include max. 5 materials"

- PRÉ DINNER DRINKS "aperitifs - short drinks" 7 cl.  
AFTER DINNER DRINKS "desserts / digestifs" max. 7 cl.  
LONG DRINKS min. 14 cl, max. 28 cl.  
81- COCKTAILS (local/yerli) "these mixtures include max. 5 materials"  
PRÉ DINNER DRINKS "aperitifs - short drinks" 7 cl.  
AFTER DINNER DRINKS "desserts / digestifs" max. 7 cl.  
LONG DRINKS min. 14 cl, max. 28 cl.  
82- non-alcoholic COCKTAILS (import) "tropical" "Barantico spc." (sh.)  
83- non-alcoholic COCKTAILS (local) "Barantico spc." (sh.)



## NON -ALCOHOLIC DRINKS / ALKOHOL FREİE GETRÄNKE / ALKOLSÜZ İÇKİLER /

boissons sans alcool/bevande analcoliche / bebidas sin alcohol / beverages "cold drinks"

84-	KOLA / COLA	250 ml./gr./g.
85-	• SPEZİ "şpetisi" 1/2 cola, 1/2 fanta "yedigün"	20 cl./200 gr.
86-	DIET KOLA / DIETCOLA "tranche limón"	250 ml./gr.
87-	7 UP "lemonade - gazoz"	250 ml./gr.
	YEDİGÜN "lemonade - orange"	250 ml./gr.
88-	MINERAL WATER "slice of lemon" (rondelle lemon)	20 cl./200 ml.
89-	SODA, LİMON SUYU, TUZ /	
90-	MINERAL WATER, LEMON JUICE, SALT	
	SODA, AYRAN, TUZ /	
91-	MINERAL WATER, BUTTER MILK, SALT "after game"	
	• APFELSPRUDEL "apfelshorle" ELMA SUYU, SODA	
92-	• ORANGENHORLE / PORTAKAL SUYU, SODA	
93-	MEYVE SULARI / FRUIT JUICES	250 ml./gr.
94-	TONİK / TONIC WATER "lemon slice, rondella limon - tranch limón"	
95-	DOMATES SUYU / TOMATO JUICE "serve salt & pepper"	
96-	SÜT / MILK / MILCH	20 cl. / 200 ml.
97-	AYRAN / • buttermilk /yoghurt drink	20 cl. / 200 ml.
98-	sıkma (pressé) PORTAKAL SUYU / fresh ORANGE JUICE	
99-	SU / WATER	0,30 cl.
100-	BUZLU ÇAY / ICE TEA / EISTEE (Iced tea / the glacé / tè ghiacciato / té helado)	

## SICAK İÇKİLER / HOT DRINKS "hot beverages"

"alkolsüz, non-alcoholic"

101-	ÇAY / TEA (Tee-Thé-Tè-Té) "çay bardağı / fincan - tea glass / cup"	
102-	KUŞBURNU ÇAYI / Rosehip tea / hibiscus	
103-	SICAK ÇİKOLATA / Hot chocolata	
104-	MEYVELİ ÇAY'lar / FRUIT TEA's / apple tea / apfeltee / elma çayı	
105-	TÜRK KAHVESİ / TURKISH COFFEE (Kahve, Coffee-Kaffee-Caffè-Café, mocca)	
106-	NESCAFÉ / INSTANT COFFEE	
107-	FILTER COFFEE (Drip coffee / Café filtre / filtreli kahve / Filterkaffee / Caffè filtro / Café filtro)	
108-	CAPPUCCINO & ESPRESSO	
109-	KAKAO / COCOA (Cacao) afrodisyak özellikli	
110-	SÜT / MILK (Milch-Lait-Latte-Leche)	
111-	KANT "slice of lemon - rondelle lemon - tranche limón"	



## SICAK İÇKİLER / HOT DRINKS

### "hot beverages" "alkollü, with alcoholic" (desserts)

- 112- CAFÉ LACER "3 cl. lacer, cognac & cream liqueur, nescafe"
- 113- • MALIBU HOT CHOCOLATE  
4 cl. malibu, hot cocoa (üzerine doldurunuz, fill up, auf füllen), cream, bitter chocolate (rendelenmiş bitter çikolata - üzerine serpiniz)
- 114- • LUMUMBA "hot chocolate with rum, or apricot brandy liqueur"
- 115- TEA OLATE "2 cl. rum or brandy" (2 cl. rum veya / or / oder/ brandy)  
COFFÉÉ OLATE "2 cl rum or brandy" (2 cl. rum veya or / oder/ brandy)
- 116- GROG 3 - 4 cl. rum or gin, 2-3 bar sp. sugar, juice of 1/2 lemon, hot water (üzerine doldurun, fill up, auf füllen )
- 117- IRISH COFFÉÉ / irlanda kahvesi / café irlandés / Eire coffee  
hot coffee with irish whiskey ( ~ 3-4 cl.) & cream on top krem şanti (cream / sahne / crème fraîche / panna, crema / Nata, crema)  
bitter chocolate (rendelenmiş bitter çikolata, üzerine serpiniz)
- 118- FRENCH COFFÉÉ / fransız kahvesi  
3 cl. Grand Marnier "liqueur", filter veya / or / oder nescafe, krem şanti (cream / sahne / crème fraîche / panna, crema / Nata, crema)  
bitter chocolate (rendelenmiş bitter çikolata, üzerine serpiniz)

\* gıda boyalı / \* dye-stuff / \* mit farbstoff, \*\* gıda boyasız /

\*\* ohne farbstoff

• tavsiye / • recommended / • empfehlen

American Express, Visa-Card, Master-Card, Euro-Card, Access

accepted - wird angenommen - kabul edilir.

fiyatlarımıza K.D.V. dahildir. / prices included service & V.A.T. / inklusivpreise  
(bedienung & mehwert steuer)

message / mesaj

Turba (peat) yakıtı nedir ?

Info.: +90. 533. 321 83 28

Sn. Fa. : Professional menu hazırlarken lütfen! cod. / art. no. ' larını yazmalısınız.  
Garson sipariş alırken menu yazısını yazıp zaman kaybedeceğine art. no.' sunu yazarak zaman kazanır & unutmaz.





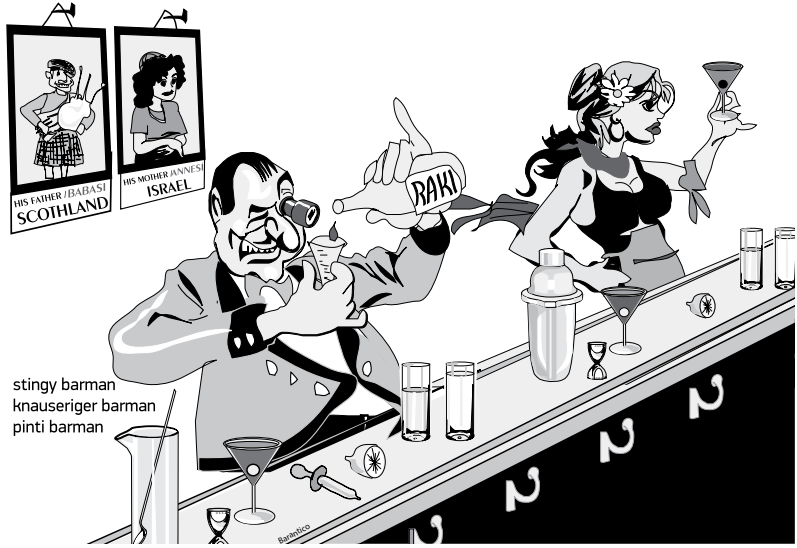



- hey barmaid bir "horozkuyruğu" lütfen, yok yok! barmen sen değil! (cısst!)







## COCKTAILS / KOKTEYLLER





### cocktail (Hahnenschwanz / horoz kuyruğu / queu de coc)









- 01  **ACAPULCO (Sh.)** **long drink/after dinner**  
 4 ice cubes, bar sp. sugar syrup, 5 cl. Tequila, 2.5 cl. crème de cassis liqueur, a tranche lemon (slice / scheibe / schnitte / fetta, trancia / tranciol lonja/ taja da/kesme), soda- water fill up (to fill (up) / füllen (auf) / doldurunuz (üzerine) /remplir / riempire)
- 02 **ADIDAS DRINK (Sh.)** **after game**  
 2 cl. mandarin syrup, 8 cl. orangejuice, egg-yolk (yolk of egg / eigelb / yumurta sarısı / rosso d'uovo, tuorlo / yema de huevo), tranche orange (slice / scheibe / schnitte / fetta, trancia / tranciol lonja/ tajada kesme), cocktail cherry (kokteyl kirazı/cocktailkirsche)
- 03 **AFTER DINNER (Sh.)**  
 1/2 Curaçao (Liqueur/Likör), Apricot brandy (Liqueur/Likör).
- 04  **ALASKA (Sh.)** **short drink**  
 3.5 cl. gin, 1.5 cl. Chartreuse yellow / gelb "liqueur (likör / liqueure / licor)





- 05 **ALEXANDRA (Sh.)** **short drink/sweet & digestif**  
 2 cl.gin, 2 cl.crème de cacao “liqueur ( likör / liqueure / licor)”,  
 2 cl. cream (sahne / rahm / krem şanti / crème fraiche / panna,  
 ceram / Nata, crema),coconut (kokosnuş, hindistan cevizi, cocos).  
 gin yerine brandy konulursa ALEXANDER olur.
- 06  **AMERICANO** **dry cocktail / aperitif/classic cocktail**  
 3 ice cubes, 2.5 cl. vermouth red, 2.5 cl. campari bitter  
 (or cinzano / cynar bitter), 3cl. soda - water, straw  
 (trinkhalm - pipette - chalumeau - paille), tranche lemon  
 (slice / scheibe / schnitte/ fetta, trancia / tranciol lonja/ tajada/kesme)
- 07 **AMERICAN GLORY**  
 3 x ice, 2 cl. dry gin, orangejuice, 2 bar sp.grenadine syrup,  
 champagne fill up (to fill (up) / füllen (auf) / doldurunuz (üzerine)  
 /remplir / riempire), 1/2 tranche orange (slice / scheibe / schnitte  
 /fetta, trancia / tranciol lonja/ tajada/kesme)
- 08  **ANGELA (Sh.)** **sweet cocktail**   
 4 cl. crème de cacao “liqueur ( likör / liqueure / licor)”,  
 2 cl.cream (sahne / rahm / krem şanti / crème fraiche  
 /panna, ceram /Nata, crema). “veya cream likör”.
- 09  **ANGEL FACE (Sh.)** **apéritif**  
 1/3 gin, 1/3 calvados (apfelschnaps), 1/3 apricot brandy  
 “liqueur (likör / liquor(e) / licor/liqueur)”.
- 10 **AMERICAN**  
 4 cl. Jim Beam, 2 cl. lemon juice (Zitronensaft/limon suyu),  
 2 cl. L-Zucker (sugar/şeker syrup “sirup / şurup / sirop  
 /scioppo /jarabe”), 6 cl. orange juice (saft/portakal suyu).
- 11 **ANNA & SIBER**  
 Bacardi rum, whisky, Grand Marnier (conag & orange liqueur,  
 konyak & portakal likörü), orange juice (portakal suyu),  
 2 d. grenadine syrup ( sirup / şurup / sirop / scioppo / jarabe),  
 "top on".
- 12 **APPETISER (Sh.)**   
 1/2 Dubonnet bitter (acı / amer (f.amère) / amaro / amargo)  
 1/2 gin, 1/2 juice of orange (portakal suyu/saft).
- 13 **ŞİRİNÉ (Sh.)** **(Profi Spc.)**   
 Whisky, Cointreau liqueur ( likör / liqueure / licor), orange juice  
 (portakal suyu).

- 14 **ASBACH-MANHATTAN (Mg.)**   
 3/4 Asbach Uralt brandy (Hugo Asbach), 1/4 vermouth red,  
 3- 4 d. angostura bitter (acı / amer (f.amère) / amaro / amargo),  
 ice, 1 cocktailcherry (kokteyl kirazı/cocktailkirsche).
- 15  **ASTORIA (Mg.)** **cold glass / glas**  
 2/3 gin, 1/3 french vermouth dry, 1 d. orange bitter (acı / amer  
 (f.amère) / amaro / amargo)
- 16  **AYDA (Sh.)** **fancy drink (Barantico Spc.)**  
 cracked ice, 3 cl. Green Curaçao BOLS liqueur ( likör / liquore / licor), 1 cl. safari liqueur ( likör / liquore / licor) orange  
 juice (portakal suyu) fill up (to fill (up) / füllen (auf) /  
 doldurunuz (üzerine) /remplir / riempire), **garnish** (garnished  
 /garnieren, garniert / garnir, garnir / guarnire, guarnito  
 /guarnecer, guarnecido) pickled /çubuk cocktailcherries & mandarins.
- 17 **ASLIM** **direct in glass/direkt bardakta (Barantico's Sp.)**  
 ice, 4 cl. mandarine or orange juice (mandalina veya portakal  
 suyu), 2.cl. grenadine juice or syrup, 1 cl. archers liqueur (li-  
 kör / liquore / licor), 1 cl. curaçao blue liqueur, 1 cl. mocca  
 liqueur.
- 18  **ARACAJU COCKTAIL (Sh.)** **long drink**  
 ice cubes 1 part (teil/bölüm) batida de Menta Cacao,  
 1 part (teil/bölüm) Crème de cacao liqueur ( likör / liquore /  
 licor), 1 part (teil/bölüm) Rossantico.
- 19 **APRICOT COCKTAIL (Sh.)**  
 3 cl. BOLS Apricot brandy, 3 cl. lemon juice (Zitronensaft/  
 limon suyu ), 1 cl. brandy, (Weinbrand), champagne  
 (sekt/şampanya), fill up (to fill (up) / füllen (auf) / doldurunuz  
 (üzerine) /remplir/riempire)
- 20 **APRITOP** **direct in glas/direkt bardakta**  
 ice, whisky, 2 cl. BOLS Apricot brandy, Ginger ale (7 up, le-  
 monade (limonade / limonata / citronnade / limonada / gazoz),  
 fill up (to fill (up) / füllen (auf) / doldurunuz (üzerine) /remplir  
 /riempire)
- 21 **ALASKA (Sh.)** **short drink**   
 3.5 cl. gin, 1.5 cl. Chartreuse yellow liqueur ( likör / liquore/licor)



- 22  **B & B (Sh.)** sweet cocktail / after dinner  
brandy benedictine D.O.M. liqueur (likör), 3 cl. whisky,  
1-2 bar sp. sugar syrup (sirup - şurup), soda - water.
- 23 **BLUE BACALICA**  
Votka, lemon juice (Zitronensaft/limon suyu), Blue Cuaçao  
liqueur ( likör / liqueure / licor), Cointreau liqueur  
( likör / liqueure / licor).
- 24 **BOBBY BURNS**  
Vermouth sweet, scotch whisky, Benedictine D.O.M. liqueur  
(likör / liquor(e) / licor).
- 25 **BETWEEN THE SHEETS**  
lemon juice (Zitronen saft/limon suyu), brandy, Cointreau liqueur  
( likör / liquor(e) / licor), yorkrum.
- 26 **BOKMAN SPECIAL**  
Tequila (tekila), smirnof vodka, archers liqueur (likör / liqore /  
licor), safari liqueur (likör / liquor(e) / licor).
- 27 **BRIAN CORCOVADO**  
Tequila (tekila), drambuie (whisky liquer / viski likörü).
- 28 **a) BAHIA** long drink / direct in glass / direkt bardakta  
ices, 1 part (teil/bölüm) Batida de limao dobre, 1 part (teil/  
bölüm) pineapple juice (ananas suyu/saft), 1 part (teil/bölüm) gin,  
1 part (teil/bölüm) orange juice (Orangensaft/portakal suyu).  
**b) BAHIA (Sh.)**  
4 cl. Bacardi rum, lemon juice (saft/suyu) pineapple juice  
(ananas saft/suyu).
- 29 **BATIDA-COCKTAIL ispo 81 (Mg.)**  
6 cl. pineapple juice (ananassaft/ananas suyu), 6 cl. Batida  
de Coco liqueur , 3 cl. lime-juice (misket limonu suyu),  
2 cl. Bacardi rum gold, dash grenadine syrup  
decor: tranche ananas, 1 straw (pippette).
- 30 **BBC**  
Baileys, banana, coconut, rum (rom / rhum).
- 31  **BANANA ROYAL (Sh)**  
3 cl. BOLS Crème de Bananes liqueur (likör / liquor(e) / licor),  
2 cl. BOLS Blue Curaçao liqueur (likör / liquor(e) / licor),  
2 cl. Weizenkorn, 2 cl. lemon juice (Zitronen saft/limon suyu),  
2 x Cocktail cherry (kokteyl kirazı/cocktailkirsche).

- 32 **BANANA BLISS (Sh)**  
3 cl. BOLS Crème de Banana liqueur (likör / liquor(e) / licor),  
3 cl. weinbrand (brandy).
- 33  **BANANA BOAT** **direct in glass / direkt bardakta**  
ices (eis/buz) 3 cl. BOLS Crème de Bananes liqueur (likör  
/liqore / licor), 2 cl. gin, 1 d. (spritzer) **grenadine syrup** ( sirup  
/ şurup / sirop /sciropo / jarabe), **orange juice** (saft/suyu) fill  
up (to fill (up) / füllen (auf) / doldurunuz (üzerine)  
/remplir/riempire).
- 34 **BÉNÉDICTINE “on the rocks / auf eis / buz üstü”**  
ices (eis/buz), 4 cl. **Bénédictine D.O.M. liqueur** (likör  
/liquor(e) / licor).
- 35 **BÉNÉDICTINE TONIC** **long drink**  
ices (eis/buz), 4 cl. **Bénédictine D.O.M.**, tonic-water: fill up  
(to fill (up) / füllen (auf) / doldurunuz (üzerine) /remplir/riempire).
- 36  **BÉNÉDICTINE YELLOWJACKET** **long drink**  
ices (eis/buz), 2 cl. **Bénédictine D.O.M.**, 2 cl. **vodka Eristoff**,  
8 cl. **orange juice** (saft/suyu), garnish  
decor: (garnished / garnieren, garniert / garnir, / guarnire, guarnito  
/guarnecer, guarnecido) 2 x **cocktail cherry** (kokteyl kirazı  
/cocktailkirsche), tranche orange “orangen/portakal or lemon”  
(slice / scheibe / schnitte / fetta, trancia /tranciol lonja/ tajada/kesme).
- 37  **BÉNÉDICTINE SUNDOWNER** **long drink**  
cracked ices “gestoßeness” (eis/buz), 2 cl. **Bénédictine**  
D.O.M., 2 cl. **grenadine syrup** ( sirup/ şurup / sirop /sciropo  
/ jarabe), 8 cl. **orange juice** (saft/suyu), garnish  
/decor: (garnished / garnieren, garniert / garnir, garnir / guarnire,  
guarnito / guarnecer, guarnecido), **tranche orange** “orangen  
/portakal or lemon” (slice / scheibe / schnitte / fetta, trancia  
/tranciol lonja/ tajada/kesme).
- 38  **BÉNÉDICTINE VERFÜHRUNG**  
cracked ice “gestoßeness” (eis/buz), 3 cl. **Bénédictine**  
D.O.M., 2 cl. **Dolfi pfirirsischlikör** (peach), 1 dash (Spritzer /  
fişkirtı) **Angostura bitter** (acı / amer (f.amère) / amaro / amargo),  
1.5 cl. **lemon juice** (saft/suyu), 1.cl. **sugar** (Zucker / şeker)  
syrup ( sirup/ şurup / sirop /sciropo / jarabe), **tranche peach**  
(slice / scheibe / schnitte / fetta, trancia / tranciol lonja/  
tajada/ kesme şeftali).



- 39 **BÉNÉDICTINE SUNBURST**  
 2 cl. **Bénédictine D.O.M.**, 2 cl. **Martini Bitter**,  
 3 cl. **orange juice** (saft/suyu), **Martini Brut Sekt**  
 (champagne /şampanya) fill up (to fill (up) / füllen (auf)  
 /doldurunuz (üzerine) /remplir/riempire) decor/garnish: **star fruit**  
 (Sternfrucht-obst / yıldız meyve).
- 40  **BÉNÉDICTINE FRENCH CLASSIC**  
 3 cl. **Bénédictine D.O.M.**, 1 cl. **cognac**, 1 d. (Spritzer /  
 fişkirtı) **Angostura bitter**, **Martini Brut Sekt**  
 (campagne/şampanya) fill up (to fill (up) / füllen (auf)  
 doldurunuz (üzerine) /remplir/riempire).
- 41  **BÉNÉDICTINE DUC DE NORMANDIE**  
 3 cl. **Bénédictine D.O.M.**, 3 cl. **Calvados Boulard**,  
 2 cl. **Dolfi Erdbeere liqueur** (strawberry / çilek likör),  
 2 cl. **lemon juice** (saft/ suyu), decor/garnish: **Erdbeere**  
 (strawberry / çilek).

### MONIN COCKTAILS (with or non-alcoholic)

- 42 **BLUE PASSION (Sh.)**  
 2 cl. **Curaçao blue syrup** ( sirup/ şurup / sirop /sciropo / ja-  
 rabe), 2 cl. **Passion fruit syrup**, 2 cl. **grapefruit juice** (greyfurt  
 suyu/saft), a dash **lemon juice** (saft/suyu).  
 decor/garnish: **tranche lemon**, **2x cocktail cherries**.
- 43 **BANCO (Sh.)**  
 2 cl. **Green banana syrup** ( sirup/ şurup / sirop /sciropo / jarabe),  
 2 cl. **coconut syrup** (hindistan cevizi / cocos), **6 cl.**  
**pineapple juice** (ananas saft/suyu), **1 dash grenadin syrup**  
 decor/garnish: **tranche lemon**, **straw** (trinkhalm - strohhalm -  
 pipette - chalumeau - paille).
- 44 **BANDOLERO (Sh.)**  
 2 cl. **rose syrup** ( sirup/ şurup / sirop /sciropo / jarabe),  
 2 cl. **passion fruit syrup**, 1 cl. **coconut syrup**, (hindistan cevizi /  
 cocos), 1 cl. **cherry syrup**, fill up with tonic-water.
- 45  **BABY SPECIAL (Sh.)**  
 1/3 (17 g./ml.) **Peach brandy liqueur** ( likör / liqueur / licor),  
 1/3 (17 g./ml.) **Apricot Brandy likör**, 1/3 (17 g./ml.) **cream**  
 (sahne / rahm / krem şanti / crème fraiche / panna, ceram /  
 Nata, crema).

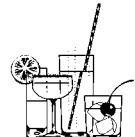



- 46 **BACARDI (Sh.)** apéritif  
3/4 Bacardi Rum, 1/4 lemon juice (saft/suyu), 1 bar sp.  
grenadine syrup ( sirup/ şurup / sirop /scioppo / jarabe).
- 47 **BARBARA (Sh.)**  
2 cl. Crème de Cacao likör, 2 cl. vodka, 2 cl. cream (sahne /  
rahm / krem şanti / crème fraiche / panna, ceram / Nata, crema).  
"bitter chocolate or coconut" (on top/üzerine serpiniz)
- 48 **BARBARELLA**  
Raspberry brandy, orange juice (portakal suyu/saft), lemon juice  
grenadine syrup ( sirup/ şurup / sirop /scioppo / jarabe).
- 49 **BANCO (Sh.)**  
ice, 1 cl. lemon juice (saft/suyu). 3 cl. Cointreau likör, 2.5 cl.  
Pisang Ambon likör,"exotic" soda-water (siphon/syphon/sifon).
- 50 **BADEN-BADEN (Sh.)**   
4 cl. vodka, 2 cl. Apricot Brandy liqueur ( likör / liquore /  
licor), decor/garnish: tranche orange (slice / scheibe /  
schnitt / fetta, trancia / tranciol lonja/ tajada/kesme), 1x Cock-  
tailcherry (kokteyl kirazı/cocktailkirsche).
- 51  **BAMBOO (Mg.)** dry. cocktail / before dinner  
2 x ices, 2.5 cl. vermouth dry., 2.5 cl. sherry (port / porto  
wine), 2 d. Angostura bitter, 1 d. orange bitter,  
1 cocktailcherry, lemon peel (schale / kabuk / pelure / buccia  
/cáscara).
- 52 **BEACH DREAM** Long drink / direct in glass  
ice cubes, (eiswürfel / buz), 4 cl. white rum, 1 cl. grenadine  
syrup, Ginger Ale, tranche orange, 1 cocktail cherry.
- 53 **BARRACUDA (Sh.)**  
Barack apricot liqueur (likör), lemon juice (saft/suyu),  
grenadine syrup (sirup/ şurup / sirop /scioppo / jarabe).  
pineapple juice (ananas saft/suyu).
- 54 **BANANA & MILK**  
Banana liqueur (muz likörü) & milk (milch/süt)  
pineapple juice (ananas saft/suyu).
- 55  **BROWN COW** kahverengi inek  
Mocca liqueur (likör), milk (milch/süt).



- 56 **BERRİ TA** Barantico sp. / modern drink  
 direct in glass-glas / direkt bardakta “Nicea / Nikaia / İznik”  
**Cracked ice, 3 cl. Blue Curoçao, BOLS likör, 1 cl. Pisang**  
**Ambon** (exotic banana liqueur), **orange juice** (saft/suyu) “fill up”  
 decor / garnish: cocktailcherries, pickled grapes./çubukta üzüm
- 57 **BEAU SITE (Sh.)**  
 2/3 **apricot brandy likör, 1/6 cream** (sahne / rahm / krem şanti / crème fraiche / panna, ceram / Nata, crema), 1/6 **gin** (cin).
- 58 **BIG BOY (Sh.)** -----  
 1/2 **cognac, 1/4 curoçao likör, 1/4 lemon juice** (saft/suyu).
- 59 **BOMBAY (Sh.)**  
 2/3 **Arrak** (hindistan / pirinçten yapılan ruma / rakıya benzer isportolu içki)- 1/6 **curoçao orange likör, 1/6 lemon juice** (saft/suyu)
- 60 **BONGO COCKTAIL SPECIAL (Sh.)**  
 Prof.Dr. **Sırmalı sp. / Club Altın Ceylan**  
 2 cl. **Gordon’s gin, 2 cl. Black & White whisky, 2 cl. Malibu**  
 (Hindistan cevizi sütlü rum), 2 cl. **vermouth bianco** (white / weiss / beyaz), 2 d. **lemon juice** (saft / suyu), 2 d. **grenadine syrup** (nar şurubu), 2 cloves ( nelke - karanfil - clou de girofleclove chioda di garofano-elavo “de especia”).
- 61 **BODY BUILDING (mixer)** short drink  
 2 cl. **Maraschino cherry liqueur** (likör), 2 d **brandy,**  
 2 cl. **cream** (sahne / rahm / krem şanti / crème fraiche / panna, ceram /Nata, crema), 1 **egg-yolk** (yolk of egg / eigelb / yumurta sarısı / rosso d’uovo, tuorlo / yema de huevo),  
 (yumurta sarısını üzerine yavaşça bırakınız).
- 62  **BURSA SWORD-SHIELD COCKTAIL (Mg.)**  Barantico sp.  
**Bursa kılıç & kalkan cocktail**  
 mise en place / vorbereitung / ön hazırlık: bardak ağzı  
 şekerlenilecek: 2 cl. **gin** (cin), 1 cl. **Grand Marnier likör, peach,**  
**apricot, orange, grapefruit juice** (greylfurt suyu/saft), 2 d.  
**grenadine syrup, 1 bar sp. honey** (bal), 1 **cinnamon** (zimt / tar  
 çın / canelle / canella / canela) & **clove** (nelke - karanfil -  
 cloude girofle - clove - chioda di garofano - elavo “de especia”),  
 1 **cocktail cherry, 1 pumpkin sugar** (kürbis zucker / kabak  
 şekeri), 1 pipette, spiral **lemon peel** (schale / kabuk / pelure /  
 buccia / cáscara).







- 63  **a) BRONX (Sh.)** classic cocktail / medium cocktail  
 3 cl. gin (cin), 1 cl. vermouth red (rot / kırmızı),  
 1 cl. vermouth dry, 1 cl. orange juice (saft/suyu),  
 1 d. angostura bitter, spiral orange peel (schale / kabuk / pelure / buccia / cáscara). 
- b) BRONX (Sh.)** classic cocktail / medium cocktail  
 1/2 gin, 1/4 dry vermouth, 1/4 sweet vermouth, dash orange juice (saft/suyu), orange slice optional.
- 64 **BRANDY SODA** long drink / digestif  
 65 **BRANDY COLA** long drink / digestif  
 66 **BRANDY (Sh.)**  
 1/1 cognac, 1 bar sp. powder sugar (puder zucker / pudra şeker), 2 d. Angostura (aromatic bitter).  
 (şeker şurup yerine grenadine / curaçao veya triple sec kullanılabilir.)
- 67  **BIJOU (Mg.)** "cold glass"  
 1/3 (17 g./ ml.) French vermouth, 1/3 gin (cin), 1/3 Chartreuse green likör, 1 d. orange bitter, 1 olive (zeytin).
- 68 **BLACK HAWK (Mg.):** "Mixglass"  
 1/2 whisky, 1/2 gin (cin).
- 69 **BLACK RUSSIAN** sweet cocktail  
 2/3 vodka, 1/3 crème de mocca likör (liqueur, licor).
- 70 **BLUE LADY (Sh.)** speical drink for hard ladies /  
 sert hanımlar için special içki  
 2 cl. gin (cin), 1 cl. Curoçao blue likör, 2 cl. lemon juice (saft/suyu), 1 cocktailcherry (kokteyl kirazı/cocktailkirsche)  
 (extra would / wunsch / istek: 1 bar sp. white of egg & brandy)
- 71 **BUTTERFLY (Sh.): (shaker)** sweet cocktail  
 1/2 Sweden-Punch (İsveç-Schweden punch-Rumbasis likör),  
 1/4 rum, 1/4 pineapple juice (ananas saft/suyu), 1 tranche ananas (rondela) (slice / scheinbe / schnitte / fetta, trancia / tranciol lonja/ tajada/kesme)
- 72  **BRANDY ALEXANDER (Sh.)** sweet cocktail / digestive / short drink  
 2 cl. brandy, 2 cl. crème de cacao (kakao / cocoa) liqueur (likör / liquore / licor), 2 cl. cream (sahne / rahm / krem şanti / crème fraîche / panna, ceram / Nata, crema), bitter chocalate "rende" (acı / amer (f.amère) / amaro / amargo) "on top"  
 (brandy yerine gin konulursa, "Alexandra" olur.)

73 **BREAKFAST (Sh.)**  
2/3 gin (cin), 1/3 grenadine syrup “nar” (sirup / şurup / sirop / scioppo / jarabe), 1 white of egg (eiweiß / yumurta akı / blanc d’œuf / chiara d’uovo, albume / clara de huevo).

74  **BRIDGE CLUB (Sh.)**  
1/2 cherry brandy “liqueur” (likör / liqueure / licor),  
1/2 french vermouth, 2 d. Orange Bitter, 2 d. cherry juice  
(saft/suyu), 1 cocktail cherry.

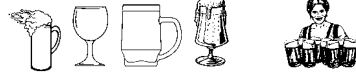
**BEER COCKTAILS recipe (recette/rezepte/reçete)**



75  **BEER PUNCH**  
2 cl. brandy, 2 cl. sherry (fortified wine / port / porto / liman şarabı) 2 cl. lemon juice (saft / suyu), 1 br sp. grenadine syrup “nar” ( sirup / şurup / sirop/ scioppo / jarabe), beer (bier / bira), fill up (to fill (up) / füllen (auf) / doldurunuz (üzerine) /remplir / riempire), lemon peel “spiral” (schale / kabuk / pelure / buccia / cáscara).

76  **CHURCHILL**  
2.5 - 3 cl. Campari bitter, beer (bier / bira) “fill up”.

77  **EROTIC BEER ----- Prof. Dr. Sırmalı Cocktails**  
“exotic” (Barantico Special for ladies)  
2 cl. Grüne banana (exotic banana likör), beer (fill up)

78 **RADLER / SHANDY**  
0.2 l. beer, 0.2 l. ginger ale lemonade (limonade / limonata / citronnade / limonada / gazoz, 7 up / ginger ale).

79 **SEXY COWBOY** “erotic”  
beer, whisky.





80 **TOWARISH**  
4 cl. vodka, 2 bar sp. lemon juice (saft / suyu), beer “fill up”.

81  **TROPIC BEER** Prof. Dr. Sırmalı Cocktails  
“erotic” (Barantico Special for ladies) 2 cl. Blue Curaçao likör (liqueur / licor), 2 cl. orange juice (saft / suyu), beer “fill up”.





82 **CAMPARI a slice of orange** on the rocks / auf Eis / buz üstü

83 **CAMPARI ORANGE slice of orange** long drink

84 **CAMPARI SODA**  
ice cubes, 1/3 campari, 2/3 orange juice.



- 85  **CAPTAIN SILVER (Sh.)**  
2 cl. lemon hart rum (73 %), 2 cl. Batida de Coco, 1 cl. bananen  
liqueur (muz likörü), 6 cl. pineapple juice (ananas saft/suyu),  
3 cl. Mango juice (saft/suyu), 1 cl. grenadine syrup (sirop/ şurup)
- 86 **CARDINAL (Sh.)**  
2 cl. gin (cin), 2 cl. vermouth dry, 2 cl. fruitjuice.  
(meyve suları)
- 87 **a) CARUSO (Sh.)** medium cocktail / digestif  
2 cl. crème de menthe likör, 2 cl. vermouth, 2 cl. gin (cin),  
(Grüne Witwe ile aynı, fark nane yaprağı, bknz. art. no. 293).  
**b) CARUSO**  
gin, lemon.
- 88  **CHARLESTON (Mg.)** short drink / after dinner drink  
1 cl. French vermouth, 1 cl. Italy vermouth, 1 bar sp. Curaçao  
orange liqueur (likör), 1 cl. gin (cin), 1 cl. Marashino cherry  
likör 1/6 cherry juice (saft/suyu), lemon peel "spiral" (schale /  
kabuk / pelure / buccia / cáscara).
- 89  **CHARLIE CHAPLIN (Sh.)** medium cocktail  
2-3 eis, (ice), 2 cl. gin, 1 cl. apricot brandy likör, 2 cl. lemon  
juice (saft/suyu), 1 cocktail cherry (kokteyl kirazı/cocktaillirsche).
- 90 **CHERRY BLOSSOM (Sh.)** apéritif  
1/3 cherry brandy likör, 1/3 cognac, 1/3 orange juice (saft/  
suyu), 3 d.grenadine syrup (sirop / şurup), 3 d. Curaçao  
orange liqueur (likör).
- 91  **CHERRY BRANDY (Sh.)**  
1/3 (17 g. / ml.) cherry brandy likör, 1/3 Italian vermouth,  
1/3 French vermouth, 1 cocktail cherry.
- 92 **CHIC & SHOCK**  
1/3 vermouth rosso (red / rot / kırmızı), 1/3 brandy, 1/3  
orange juice & lemon juice (saft/suyu) 1 x rondela lemon + 1 x  
rondela orange "tranche (slice / scheibe / schnitte / fetta, tran-  
cia / tranciol lonja/ tajada/kesme)".
- 93 **CLARIDGE (Sh.)** digestif / medium cocktail  
1/3 gin (cin), 1/3 vermouth, 1/6 cointreau liqueur (likör), 1/6  
apricot brandy liqueur (kayısı likör).



- 94 **CLUB (Sh.)**  
2/3 gin, 1/6 Italian vermouth, 1/6 chartreuse yellow likör,  
1 bar sp. grenadine syrup (sirop / şurup) 1 d. orange bitter,  
1 olive (zeytin).
- 95  **COLONIAL (Sh.)**  
2/3 gin (cin), 1/3 grapefruit juice (greyfurt saft/suyu),  
3 d. maraschino cherry likör (liqueur, licor).
- 96  **COCA COLA MINZE (Mg.)**  
2 cl. menthe likör, 2 bar sp. lemon juice (saft/suyu), Coca Cola,  
tranche lemon (slice / scheibe / schnitte / fetta, trancia /  
tranciol lonja/ tajada/kesme), mint sprigs (peppermint  
“nane yaprakları / pfefferminze / menthe (poivrée / menta,  
hierbabuena)”.
- 97  **CRAZY BARMAN**  
Baileys cream likör (liqueur, licor), mocca likör, Grand  
Marnier likör, cream de coco.
- 98  **CUBA LIBRE** **direct in glass / direkt bardakta**  
Ice cubes, 3/4 white rum, 1/4 fresh lime (taze / frisch / frais  
(f.fraîche) / fresco) juice, Fill with Coke.  
(Build the rum & lime juice into on ice-filled glass & stir in Coke.)
- 99  **CYNAR SODA** **aperitifs / bitters**  
100 **CYNAR ORANGE** **aperitifs / bitters**

## COBBLERS

Temel reçete: önceden soğutulmuş cobbler bardağında direkt hazırlanır.  
direct in glass / direkt bardakt long drinks / fancy drinks

- 101 **BRANDY**  
5 cl. brandy, 2 d. Curaçao likör, 2 d. grenadine syrup (sirop/  
şurup), cracked ices, fruits (obst / meyveler).
- 102  **CHAMPAGNE**  
5 cl. champagne (şampanya), 2 d. Curaçao likör, 2 cl. brandy,  
2 d. grenadine syrup cracked ices (zerschlagenem Eis/kırılmış  
buzlar), fruits (obst / meyveler).
- 103  **MELONEN COBBLER** **In season / sezonunda**  
4 x ice cubes, 3 x cubes melon & water melon (3x kaşık kavun  
& karpuz), 1 d. Curaçao likör, 1 d Cointreau liqueur, 1 d.  
cognac, champagne (fill up), spoon & straw (kaşık & pippette).

104

**SHERRY**

5 cl. **sherry** (fortified wines / port / porto / liman şarabı). 2 d.  
Curaçao likör, 2 d. **brandy**, 2 d. **grenadine**, cracked ice & fruits.

**COCKTAILS WITH / MIT CHAMPAGNE****ŞAMPANYALI KOKTEYLLER**

recipes (recettes/rezeptes/reçeteler) / direct in glass / direkt bardakta

105

**AMERICAN GLORY**

3 x ice, 2 cl. **orange juice** (saft/suyu), 2 bar sp. **grenadine syrup** “nar” (sirup / şurup / sirop / sciroppo / jarabe), **champagne** fill up (to fill (up) / füllen (auf) / doldurunuz (üzerine) / remplir / ri-empire), 1/2 rondela orange & tranche lemon (slice / scheibe / schnitte / fetta, trancia / tranciol lonja/ tajada/kesme).

106

**APEROL ROYAL**

3-4 cl. **Aperol sekt** (or / oder / veya) **champagner brut** Aperol (fill up / auffüllen / üzerine doldurunuz) “in ein vorgekühltes sektglas / önceden soğutulmuş sekt / şampanya kadehi”

107

**a) BELLINI**

**Archer’s apricot brandy liqueur**, (kayısı likörü), **champagne** (şampanya) fill up.

**b) BELLINI**

5 cl. **peach juice** (şeftali suyu / saft), 10 cl. **champagne**, 1 d. **grenadine syrup**, **vodka**, **apricot brandy likör**, **lemon juice**.

108

**BLUE MOON SPECIAL (Sh.)****(Dr.Oetker cocktails)**

**after game / after sport drink / spor sonrası**

mise en place / vorbereitung / ön hazırlık:

Bardak ağzı şekerlenecek. 2 cl. **gin**, 2 cl. **Curaçao Blue likör**, **champagne**. fill up.



109

**BLUE TANGO**

2 cl. **BOLS Blue Curaçao likör**, **sekt** (şampanya / champagne) fill up (to fill (up) / füllen (auf) / doldurunuz (üzerine) / remplir / riempire), garnish “decor” (garnished / garnieren, garniert / garnir, garnir / guarnire, guarnito / guarnecer, guarnececido):







1 **grappes** (Weintraube / üzüm).





110



**BLUE CHAMPAGNE**

4 dashes (spritzer / fişkirtı), **Curaçao Blue liqueur** (likör / licor) 10 cl. **cold champagne** (şampanya), a slice of orange.



- 111 **BLUE HEAVEN**  
champagne, vodka, martini dry vermouth, lemon juice (saft / suyu), Blue Curaçao liqueur (likör).
- 112 **BRIGADE**  
apricot brandy likör, curaçao likör, orange juice (saft / suyu), champagne fill up (to fill (up) / füllen (auf) / doldurunuz (üzerine) /remplir / riempire).
- 113 **CHICAGO COCKTAIL** before dinner  
2 x ice, 4 cl. brandy, 1 bar sp. curaçao likör, 1 d. angostura bitter (acı / amer (f.amère) / amaro / amargo), champagne. fill up.
- 114  **CHAMPAGNE COCKTAIL**  
champagne (fill with iced champagne / soğuk şampanya ile doldurunuz), 1 lump sugar (cube / küp şeker), (saturate with bitters. Add brandy), a cherry “1 cocktail cherry (kokteyl kirazı/cocktailkirsche)”, slice of orange (tranche portakal).
- 115 **CÔTE D’AZUR / sahil kenarı**  
Curaçao Blue liqueur (likör), gin (cin), lemon juice (saft / suyu), champagne (fill up), 1 cocktailcherry.
- 116 **CRAZY HORSE / çılgın at**  
champagne, whisky strawberry syrup (Crème de fraise / çilek şurubu), Crème de banana liqueur (likör).
- 117  **CRUSTINO**  
mise en place / vorbereitung / ön hazırlık:  
 Bardak ağzı şekerlenilecek. 2 bar sp. grenadine syrup, 2 bar sp. lemon juice (saft / suyu), 6 cl. port wine (fortified wines / port / porto / liman şarabı).
- 118  **BACHUS (Sh.)** Alijan Bayramov special.  
4 cl. brandy, 2 cl. Apricot Brandy, 2 cl. lemon juice, white egg (yumurta beyazı), 1 bar sp. Grenadine.
- 119  **FRENCH 75 (Sh.)**  
2 ice, 1 cl. lemon juice (saft / suyu), 2 cl. gin (cin), 2 cl. cointreau liqueur (likör / licor), 1 cl. pernod (french rakı), champagne fill up (to fill (up) / füllen (auf) / doldurunuz (üzerine) /remplir / riempire).
- 120  **FRENCH CONNECTION**  
champagne, Ameretto di Saronno (acı badem likörü / bitter almonds liqueur “likör / licor”)

- 121 **FROZEN CARUSO COCKTAIL**  
cracked ice (gestoßenem eis / kırılmış buzlar) 2 cl. **BOLS**  
**Teardrop**, 2.cl **gin** (cin).
- 122  **FLYING / uçmak / fliegen**  
**gin** (cin), **cointreau liqueur** (likör), 2 cl. **lemon juice** (saft / suyu), **champagne**. fill up.
- 123 **GOLDEN MONOPOLE (Sh.)**  
1 cl. **O'DARBY Dairy Crèam Irish liqueur** (likör / licor),  
1 dash **pfefferminz weiß** (peppermint white), 3 cl. **orange juice**  
(saft / suyu), **champagne HEIDSIECK DRY MONOPOLE BRUT**  
fill up (auffüllen / üzerine doldurunuz) Decor: **peppermint**  
**sprigs** (nane yaprakları / pfefferminze / menthe (poivrée).
- 124 **GOLDEN LADY / altın leydi**  
2 cl. **Asbach Uralt brandy**, 1 cl. **Tripple Sec** (orange liqueur /  
likör), 2 cl. **orange juice** (saft / suyu), **champagne** fill up.
- 125  **I.B.U.**  
**Apricot brandy likör**, **curaçao likör**, **brandy**,  
fill up with **champagne**.
- 126 **KIR ROYAL** "dry cocktail" / mexican style  
1 cl. **crème de cassis liqueur** (red currants / johannesbeer /  
frenk üzümü), **champagne** fill up.(oder als Dessert über eis.  
veya Dessert olarak dondurma üzeri)
- 127 **LEO'S SPECIAL (Sh.)**  
2-3 ice, 2 cl. **brandy**, 2 cl. **curaçao triple sec liqueur**, 1 cl.  
**orange juice** (saft / suyu), 1 d. **grapefruit juice** (greyfurt suyu  
/ saft), **champagne**. fill up, 1 **cocktail cherry** (kokteyl kirazı).
- 128  **MINT-COCKTAIL**  
2 cl. **lemon juice** (saft / suyu), 2 cl. **orange juice**, 1 cl. **crème**  
**de mente likör**, 1 cl. **sugar** "zucker / şurup" syrup ( sirup / şu-  
rup / sirop / sciroppo / jarabe), 1 cl. **champagne**. fill up.
- 129 **MONTE CARLO imperial (Sh.)**  
2-3 ice, 2.cl. **dry gin**, 1.5 cl. **crème de mente white likör**,  
2 bar sp. **limett juice** "lumien / misket limonu" juice (saft /  
suyu), "or **lemon juice**", **champagne**. fill up.
- 130  **MONINO**  
2 cl. **peach syrup** (sirop / şurup), 10 cl. **champagne** or dry  
**sparkling wine** fill up. decor: tranche peach / şeftali.

- 131  **MOULIN ROUGE**  
2 cl. **brandy**, 2 cl. **pineapple juice** (ananas suyu / saft), 1 bar  
sp. **powder sugar** (puder / zucker / pudra şekeri),  
1 **cocktail cherry**.
- 132 **a) MIMOSA**  
champagne, **orange juice** (saft / suyu), 1 **cocktail cherry**.  
**b) MIMOSA**  
champagne, **orange juice** (saft / suyu), **grenadine syrup**.
- 133 **MY FAIR LADY** **before dinner**  
cherry juice, **curaçao likör**, **grenadine syrup**, **champagne**. fill up.
- 134 **OHIO**  
1 cl. **Canadian whiskey**, 1 d. **vermouth red** (rosso / kırmızı),  
2 d. **angostura bitter**, 2 d. **curaçao orange likör**, **champagne**.  
fill up, 1 **cocktail cherry** (kokteyl kirazı).
- 135  **PETITE FLEUR**  
**bacardi rum**, **cointreau likör**, **grapefruit juice**, **champagne**  
fill up, decor: **fruits** (meyveler).
- 136 **a) PRINCE OF WALES / galler prensi (Sh.)**  
ice, 2 cl. **brandy**, 1 cl. **orange curaçao likör**, 1 d. **angostura**  
**bitter**, **champagne**. fill up, decor: **cocktail cherry & fruit**.  
**b) PRINCE OF WALES / galler prensi (Sh.)**  
**champagne**, **triple sec likör**, **brandy**, **angostura bitter**.
- 137  **PEACH LADY**  
**champagne**, **archer's**, **orange juice**, **lemon juice** (saft / suyu).
- 138 **RED KISS**  
**Lemon Hart Rum**, **Cherry Heering likör**, **champagne**. fill up.
- 139 **THE BUFFALO BILL**  
ice, 1 cl. **bourbon whiskey**, 3 cl. **marie brizard peach liqueur**,  
**champagne**. fill up. decor / garnish: with **melon balls** (yuvarlak  
özel kaşığı ile kavun topu “örnek: kaşık ayva gibi”)
- 140 **TURKENBLUT / turkish blood / türk kanı**  
**red wine** (rot wein / kırmızı şarap), **champagne**. fill up.





COLLINS / punch family / fizz'lere benzer  
(Sh.), (Mixer) or direct in glass long drinks



141 a) **TOM COLLINS**

1/2 gin, juice of 1 lemon, 1 bar sp. of sugar syrup (zucker sirop / şeker şurubu), soda - water (add last) "siphon", lemon slice, straws (pipette). "Collins may also be shaken with the addition of a little egg white & then topped with soda.

(cin yerine whisky konulursa JOHN COLLINS olur.)

b) **TOM COLLINS**

5 cl. gin (cin), 1 lemon juice (saft / suyu), 2 bar sp. sugar, (zucker / şeker), 1 cl. soda - water (siphon) "syphon / sifon" decor / garnish: fruits (obst / meyveler) & cocktail cherry (kokteyl kirazı/cocktailkirsche).

142 **JOHN COLLINS / whisky collins**

5 cl. whisky, 1 lemon juice (saft / suyu), 2 bar sp. sugar or syrup, fruits (obst / meyveler) & cocktail cherry (kokteyl kirazı/cocktailkirsche). "whisky yerine cin konulursa TOM COLLINS olur.

143 **BACARDI COLLINS**

5 cl. rum, 1 lemon juice (saft / suyu), 2 bar sp. sugar or syrup, fruits (obst / meyveler) & cocktail cherry (kokteyl kirazı/cocktailkirsche).

COOLERS / Soğukluklar

(a cooler is a tall warm weather drink not unlike an individual punch)

long drinks

144 **PICCOLO COOLER (Sh.)**

Barantico Spc.

5 cl. vodka, 1 cl. crème de mente likör, 2 bar sp. cream (sahne / rahm / krem şanti / crème fraiche / panna, ceram / Nata, crema), 1/2 lemon juice (saft/suyu), 1 cl. pineapple (ananas) & mandarin juice (tangerine / mandalina suyu).

145 **CARIBBEAN COOLER**

exotic long drink

bacardi rum, crème de mente likör, ginger ale "lemonade (limonade / limonata / citronnade / limonada / gazoz)", "fill up".

146 **SCOTCH COOLER (Sh.)**



3 - 4 ice, 2.5 cl. lemon juice, 5 cl. scotch whisky, 1 bar sp. sugar syrup or sugar, cold ginger ale or tonic, "fill up".



## CRUSTAS after dinner drinks

mise en place / vorbereitung / ön hazırlık:

Kesilmiş bir limonun suyunu bardak ağzında (rand) gezdirerek bardak ağzını nemlendiriniz & toz şeker üzerinde hafifçe gezdirip şekerleyiniz.

147 **DAWN CRUSTA (Sh.)** long drink / fancy drinks

1 -2 ice, **white rum**, 1 cl. **orange juice** (saft / suyu), 1 bar sp. **apricot brandy** likör (liqueur / licor), 1 d. **grenadine syrup** (sirup / şurup / sirop / sciroppo / jarabe), **spiral orange peel** (schale / kabuk / pelure / buccia / cáscara)

148  **BRANDY CRUSTA (Sh.)** long drink

**Brandy**, 2 bar sp. **marashino cherry** likör (liqueur / licor), **dashes angostura bitter** (acı / amer (f.amère) / amaro / amargo), 2 bar sp. **lemon juice** fresh (taze / frisch / frais (f.fraîche) / fresco), decor / garnish: **cocktail cherry** (kokteyl kirazı/cocktail-kirsche)

## CUPS / bowls

party drinks

recipe (recette/rezepite/reçete)

mise en place / vorbereitung / ön hazırlık:

İçkiler önceden hazırlanarak soğutulur.

(These delectable wine cocktails are made with brandy & triple sec mixed with wine, champagne or cider.)

149 **CLARET CUP**

4 bar sp. **powdered sugar** (puder zucker / pudra şekeri), 6 oz. (ounce) **carbonated water**, 1 oz. **triple sec** (orange likör) “liqueur ( likör / liqueur / licor)”, 2 oz. **brandy**, 16 oz. **clared**, decor / garnish: many fruits (obst / meyveler), serve: **red wine glass**.

150 **CIDER CUP**

4 bar sp. **powdered sugar** (puder zucker / pudra şekeri), 6 oz. (ounce) **carbonated water**, 1 oz. **triple sec** (orange likör) “liqueur ( likör / liqueur / licor)”, 2 oz. **brandy**, 16 oz. **apple cider** decor / garnish: **lots of fruit** (obst / meyveler), serve: **red wine glass**

151 **a) DAIQUIRI (Sh.)** on the rocks / medium cocktail

2 - 3 ice, 2.5 cl. **limett juice** (misket / yeşil limon suyu), 3 bar sp. **sugar syrup** (sirup / şurup), 5 cl. **white rum**, 4 - 5 ice (sonradan ilave/ again off / noch mall), 1 cl. **marashino cherry** likör

(bu cocktail RUM SOUR benzeridir / ähnlich).

**b) DAIQUIRI COCKTAIL (Sh.)** American syle / stili medium cocktail

2 - 3 ice, 2.5 cl. **limett juice** (misket limon suyu), 5 cl. **white rum**, 1 bar sp. **sugar syrup** (zucker sirop / şeker şurubu), 1 bar sp. **curaçao orange likör**, + 3-4 ice (sonradan ilave / again off / noch mall) tranche limett or lemon (slice / scheibe / schnitte / fetta, trancia / tranciol lonja/ tajada/kesme), **cocktail cherry** (kokteyl kirazı/cocktailkirsche), **straw** (trinkhalm / strohhalm / pipette / chalumeau / paille).

**c) DAIQUIRI (Sh.)** after dinner / medium cocktail

1 ice, 4 cl. **white rum**, 4 cl. **lemon juice**, 1 1/2 bar sp. **sugar syrup** (or / oder / veya) **grenadine syrup** “nar şurubu”

(bu cocktail bir RUM SOUR benzeridir.)

**d) DAIQUIRI (Sh.)**

1/2 **white rum**, 1/4 **fresh lime or lemon juice** fresh (taze / frisch / frais (f.fraîche) / fresco), 1/4 **gomme syrup** (sirup / şurup / sirop / sciroppo / jarabe)

**e) DAIQUIRI (Sh.)**

**bacardi rum**, **lemon juice** (saft/suyu), **sugar syrup** (sirop / şurup), **egg white** “egg-yolk” (yolk of egg / eigelb / yumurta sarısı / rosso d'uovo, tuorlo / yema de huevo).

152 **DALTON BROTHERS**

**safari likör** (liqueur, licor), **orange juice** (saft / suyu), **pineapple juice** (ananas saft / suyu).

153 **DEAUVILLE (Sh.)**

1/4 **Calvados** (apple / apfel / elma - schnaps), 1/4 **cognac**, 1/4 **cointreau likör** (liqueur, licor), 1/4 **lemon juice** (saft / suyu).

154 **DISCO NIGHT (Sh.)**

3 cl. **bacardi rum**, 2 cl. **red orange**, 2 cl. **lemon juice**, (zitronen saft / suyu), 8 cl. **maracuja juice** (saft / suyu), 2 cl. **pineapple juice** (ananas saft / suyu), 1cl. **strawberry syrup** (erdbeer sirup/ çilek şurubu).



155 **DIXE (Sh.)**

1/2 **cognac**, 1/4 **vermouth**, 1/4 **anissette** (anis/ aniseed / anason likörü).



- 156 **DRAMBUIE TONIC**  
4 cl. **drambuie** (whisky liqueur / viski likörü), **tonic - water**,  
1 **rondela orange** “tranche (slice / scheibe / schnitte / fetta,  
trancia / tranciol lonja/ tajada/kesme)”
- 157 **DOCTOR (Sh.)**  
1/3 **Sweden - punch** (Schweden / İsveç punch / Rumbasis likör),  
1/3 **orange juice** (saft / suyu), 1/3 **lemon juice** (saft / suyu).
- 158 **DUCHESS (Sh.)**  
1/3 **Italian vermouth**, 1/3 **French vermouth**, 1/3 **aniset** (anis  
/ aniseed / anason likörü).

### DAISIES

These overgrown cocktails are made of liquor (likör/liqueur), grenadine or liqueurs & lemon or lime juice & usually shaken with cracked ice

long drinks / lady drinks

- 159 **BRANDY (Sh.)**  
5 cl. **brandy**, 2.5 cl. **grenadine syrup** (nar şurubu), 1/2 **juice of lemon**, 3-4 **cocktail cherry** (kokteyl kirazı/cocktailkirsche),  
**soda - water** (siphon / syphon / sifon).
- 160 **BRANDY DAISY (Sh.)**  
4 cl. **brandy**, 1-2 cl. **fresh lemon juice**, 2 bar sp. **grenadine syrup**, **soda - water** (siphon / syphon / sifon), decor: **fruit & peppermint sprigs** (nane yaprakları / pfefferminze / menthe (poivrée / menta, hierbabuena).
- 161 **GIN (Sh.)**  
5 cl. **gin**, 2.5 cl. **grenadine syrup**, 1/2 **juice of lemon**, 3-4 **cocktail cherry** (kokteyl kirazı/cocktailkirsche), **soda - water** (siphon / syphon / sifon).
- 162 **VODKA DAISY (Sh.)**  
4 cl. **vodka**, 2 cl. **lemon juice** (saft / suyu), 2 cl. **Orgeat** (almond) **syrup** (sirup / şurup / sirop / sciroppo / jarabe) (serve over ice).

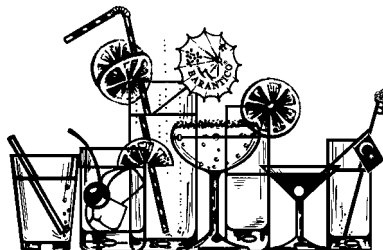

## DESSERT COCKTAILS

favorite for ladies

after dinner cocktails

recipe (recette/rezepte/reçete)



### 163 BLUE MOON (Sh.)

2 cl. Tequila, 1 cl. Galliano liqueur (likör / liquore / licor),  
1 cl. curaçao blue liqueur (likör), 4 cl. sweet cream (süße  
sahne/ tatlı krem şanti).

### 164 FIFTH AVENUE (Sh.)

2 cl. Creme de Cacao white likör, 1 cl. apricot brandy likör,  
2 cl. orange juice (saft / suyu) 2 cl. sweet cream (süße sahne /  
tatlı krem şanti).

### 165 GRASSHOPPER / çekirge (Sh.)



2 - 3 cl. Creme de Cacao white likör, 1 cl. creme de mente  
green likör, 4 cl. cream (sahne / rahm / krem şanti / crème fra-  
iche / panna, ceram / Nata, crema).

### 166 GOLDEN CADILLAC (Sh.)



1 cl. Galliano likör, 2 cl. Creme de Cacao white likör, 2 cl.  
orange juice (saft / suyu) 2 cl. sweet cream (süße sahne / tatlı  
krem şanti).

### 167 GOLDEN DREAM (Sh.)

1 cl. Galliano likör, 2 cl. cointreau likör, 1 cl. orange juice  
(saft / suyu), 2 cl. sweet cream (süße sahne / tatlı krem şanti).

## DIGESTIFS

Als digestifs solten pure (pur / sade) spirituosen niemals auf eis gereicht werden.  
Dies bleibt den Cocktails vorbehalten.

sade (pur / pure) ispirotolu içkiler, digestif sade olarak kesinlikle buz atılmadan  
içilirler. (örneğin: malt viskiler gibi)

recipe (recette/rezepte/reçete)

### 168 BRANDY PORT

direct in glass / direkt bardakta

ice cubes (würfeleis / küp buz), 3 cl. port (tawny) "fortified  
wine/ port / porto / liman şarabı", 3 cl. brandy (brendi).

### 169 GODFATHER / vafiz (manevi) baba

direct in glas / direkt bardakta

ice cubes (würfeleis / küp buz), 4 cl. bourbon whiskey, 2 cl.  
amaretto liqueur (acıbadem likörü).



- 170 **GOLDEN NAIL** **direct in glass / direkt bardakta**  
ice cubes (würfeleis / küp buz), 4 cl. **bourbon whiskey**, 2 cl.  
**southern comfort liqueur** (viski & bal likörü).
- 171 **RUSTY NAIL** **direct in glass / direkt bardakta**  
ice cubes (würfeleis / küp buz), 4 cl. **scotch whisky**, 2 cl.  
**drambuie whisky liqueur** (likör / liqueur / licor).
- 172 **VODKA STINGER / CORPSE REVIVER** **direct in glass / direkt bardakta**  
**cracked ice** (geschlagenem eis / kırılmış buzlar), 4 cl. **vodka**  
(wodka / votka), 2 cl. **crème de menthe white liqueur** (likör).

### DIVERSE DRINKS / değişik içkiler

- long drinks**  
**recipe (recette/rezpte/reçete)**
- 173 **APRICOT BLOSSOM (Sh.)** **Barantico Spc.**  
2 ice cubes (würfeleis / küp buz), 1 cl. **apricot brandy** likör,  
2 cl. **orange juice** (saft / suyu), 2 cl. **prune brandy** (acquavite /  
akvavit / aquavit / aquávit) “tahıldan, patatesten,  
baharatlardan & bitkilerden yapılan İskandinav brendi”
- 174 **ATOM AMERICANO** **Barantico spc. 7 cl. (tamamı)**  
“barut suyu” **direct in glass / direkt bardakta**  
**brandy, whisky, vodka, gin, orange liqueur**, 1 d. **Angostura**  
**bitter**, 1 clove (nelke - karanfil - clou de girofle - clove - chi-oda di  
garofano - elavo “de especia”), 1 **cocktail cherry**, a slice  
of **lemon**, a slice of **orange**.
- 175 **SCREWDRIVER / tornavida/after dinner &medium cocktail**  
**vodka** (wodka / votka), **orange juice** (saft / suyu).  
(Galliano likör konulursa **HARVEY'S WALLBANGER** olur.)
- 176 **ORANGE BLOSSOM (Sh.)** **before dinner & medium cocktail**  
1/2 **gin** (cin), 1/2 **orange juice** (saft/suyu) (1d. grenadine syrup  
konulabilir.)
- 177 **Pharm./Apoth./Ecz.YAZAN's COCKTAIL (Sh.)** **Barantico Spc.**  
2 cl. **campari** 2 cl. **Gordon's gin**, 2. cl. **malibu rum**, fresh  
**orange juice** (taze / frisch / frais (f.fraîche) / fresco), fresh  
**mandarine juice**, dashes **angostura bitter**.
- 178 **ELIZABETH & KISS ME (Sh.)** **Prof.Dr.Sırmalı cocktails Barantico Spc.**  
4 cl. **whisky**, 3 cl. **green curaçao likör**, 3 cl. **bacardi rum**,  
3 cl. **soda - water**, fill up.

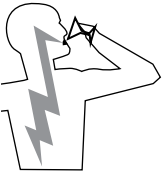



- 179 **EL DIABLO** exotic long drink  
Tequila, Crème de Casiss (red currants / rote johannisbeeren / frenk üzümü) liqueur (likör / licor), **Ginger Alle** “lemonade (limonade/ limonata / citronnade / limonada / gazoz)”.
- 180 **EL DORADO (Sh.)**  
1/2 Sweden punch (Schweden punch/Rumbasis likör/from Batavia, scandiavian), 1/4 whisky, 1/4 orange juice (suyu).
- 181 **EMPIRE (Mg.)** before dinner drink  
2.5 cl. gin, 1-2 cl. Calvados (apple brandy), 1-2 apricot brandy likör (liqueur, licor), cocktail cherry.

## EGG - NOGS

sütten veya yumurta ile yapılan kokteyller soğuk veya sıcak içilebilir / sabah içkisi / punch kategorisindedirler  
recipe (recette/rezepte/reçete)

### fancy drinks

- 182 **BALTIMORE EGG - NOG**  
1 egg, sugar (zucker / şeker), brandy, dark rum, milk (milch / süt), nutmeg (muskatnuß / hint cevizi / (Noix de) muscade / muscat / Noce moscata / Nuez moscada), top on (üzerine serpiniz).
- 183  **BREAKFAST EGG-NOG (Sh.)**  
1 egg (yumurta), 2 cl. orange liqueur (portakal likörü), 2 cl. brandy, 6 cl. milk (milch / süt), fill up (to fill (up) / füllen (auf) / doldurunuz (üzerine) / remplir / riempire) nutmeg (muskatnuß / hint cevizi / (Noix de) muscade / muscat / Noce moscata / Nuez moscada) “top on / üzerine serpiniz” (süt “Sh.” shaker’e girerse kesilir.)
- 184 **a) EGG - NOG (Sh.)**  
1 egg (yumurta), sugar (zucker / şeker), brandy, milk (milch / süt) fill up (to fill (up) / füllen (auf) / doldurunuz (üzerine) / remplir / riempire) little grated, nutmeg (muskatnuß / hint cevizi / (Noix de) muscade / muscat / Noce moscata / Nuez moscada) “top on/ üzerine serpiniz”.
- b) EGG - NOG (Sh.)**  
4 cl. brandy, 1 bar sp. sugar (zucker / şeker), 1 egg (yumurta), 6 cl. milk (milch / süt) fill up (to fill (up) / füllen (auf) / doldurunuz (üzerine) / remplir / riempire) “süt shaker’den sonra bardağa süzülür, hint cevizi rendelenerek üzerine serpilir.

- 185  **PICCOLO & BARANTICO HOG (Sh.)** **Barantico spc.**  
2 cl. **gin**, 2 cl. **vodka** (or rum / whisky), 1 **egg**, 2 bar sp. **cream**, **milk** (milch / süt), **muscat** (hint cevizi).
- 186 **FAVORITE (Sh.)**  
2 cl. **gin** (cin), 2 cl. **vermouth**, 2 cl. **apricot brandy likör**, 1 d. **lemon juice** (saft / suyu).
- 187 **a) FIRST LOVE (Sh.)**  
1/2 **crème de cacao likör**, 1/2 **Grand Marnier** (cognac & orange liqueur), 1 bar sp. **cream** (sahne / rahm / krem şanti / crème fraiche / panna, ceram / Nata, crema).  
**b) FIRST LOVE (Sh.)**  
**Baileys, Grand Marnier, Cream de coco.**
- 188 **FLAMINGO (Sh.)** **sweet cocktail / before dinner**  
**gin**, **apricot brandy liqueur** (likör, licor), **lemon juice**, **grenadine syrup** (sirup / şurup / sirop / sciropo / jarabe).
- 189 **FRENCH COCKTAIL (Sh.)**  
1 **ice**, 3 cl. **gin**, 2 cl. **pernod** (french rakı), 1 bar sp. **grenadine**
- 190 **FRUIT COCKTAIL (Sh.)** ----- **Barantico spc.**  
3-4 **ice**, 3 cl. **gin**, 1 cl. **curaçao liqueur** (likör, licor), **cherry orange-peach juice**, **cinnamon** (zimt / tarçın / canelle / canella / canela), **clove** (nelke - karanfil - clou de girofle - clove - chi-oda di garofano - elavo "de especia"), 1 d. **orange bitter**, 1 **cocktail cherry**, 1 **rondela lemon**.

## FRAPPES

arzu edilen likörün kar buz ileağzına kadar doldurulmuş kadehle servis etme şeklidir. **after dinner drinks**



- 191 **PFERERMINZ FRAPPÉ**  
4 cl. **BOLS Tear drop**, small **straw**. (küçük pipette, klein strohalm) (über gestoßenes eis / schenee eis in ein cocktail glass geben.)
- 192 **NAP FRAPPÉ**  
1 / 3 **kümmel** (caraway-anise seeds likör / liqueur), 1/3 **chartreuse green liqueur**, 1/3 **brandy**, small **straw**. (küçük pipette, kl.strohalm)

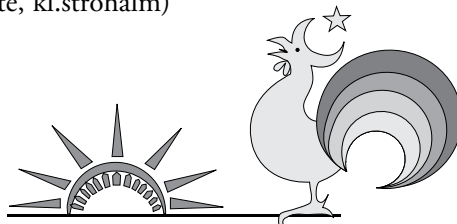



## FIXES

Daha küçük hacimli içkilerdir, meyvelerle dekore edilir, pipett'le servis edilir.

These sweet miniature cobbblers are served in highball glasses, served with a straw.

direct in glass / direk bardakta

recipe (recette/rezепte/reçete)

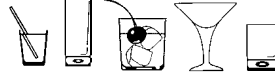

193

### **BRANDY FIX**

2 cl. **brandy**, 2 cl. **cherry liqueur** (vişne likörü), 2 cl. **lemon juice** (saft / suyu), 1 bar sp. **sugar syrup**, decor / garnish: 1 **cocktail cherry**, tranche **orange & lemon**, straw (pipette).

194

### **GIN FIX**

4 cl. **gin**, 2 cl. **lemon juice**, 1 bar sp. **sugar syrup**, tranche **lemon**, straw (pipette / strohhalm)



## FIZZES / fışirtılar

Fizzes are made with liqueur, citrus juices & sugar, then filled with “fizz” (carbonated beverage) “sipfon / syphon / sifon”

Fixes & collins'e benzerler, geniş hacimlidirler, genellikle shaker ile hazırlanırlar. long drinks / fancy drinks

Temel reçete / recipe / rezept / recette:

mise en place / vorbereitung / ön hazırlık: kesilmiş bir limon suyunu bardak ağzında (rand) gezdirerek bardak ağzını nemlendiriniz & toz şeker üzerinde hafifçe gezdirip şekerleyiniz veya şekersiz.

195

### **APRICOT FIZZ (Sh.)**

4 cl. **BOLS apricot brandy liqueur** (likör), 4 cl. **orange juice** (saft / suyu) 2 cl. **lemon juice** (saft / suyu) , **soda - water**.

196

### **BACARDI FIZZ (Sh.)**

4 cl. **bacardi white rum**, 2 cl. **lemon juice** (saft / suyu), 1 -2 bar sp. **sugar syrup**, **soda - water syphon**, tranche **lemon**. (bacardi yerine dubonnet konulduğunda **DUBONNET FIZZ** olur.)

197



### **DRAMBUIE FIZZ (Sh.)**

4 cl. **Drambuie Scotch whisky likör**, 3 cl. **limett or lemon juice fresh** (taze / frisch / frais (f.fraîche) / fresco), **soda - water fill up**. (syphon), 1/2 **tranche lemon** & 1 **cocktail cherry**



198

### **DUBONNET FIZZ (Sh.)**

4 cl. **dubonnet** (ret / rot / kırmızı), 1 b. sp. **cherry brandy liqueur** (likör), 2 cl. **orange juice**, 2 cl. **lemon juice**, 1 bar sp. **white of egg**, **soda -water**. syphon (sifon)

(dubonnet yerine bacardi konulduğunda **BACARDI FIZZ** olur.)



- 199 **GIN FIZZ (Sh.)**  
5 cl. **gin**, 1 **lemon juice**, 1 bar sp. **sugar syrup**, 1 cl. **soda water syphon**, 1 / 2 **tranche lemon** & 1 **cocktail cherry** (kokteyl kirazı/cocktailkirsche)  
(1 yumurta sarısı ilave edildiğinde **GOLDEN FIZZ** olur)  
(1 yumurta akı ilave edildiğinde **SILVER FIZZ** olur.)
- 200  **GRAPEFRUIT FIZZ (Sh.)**  
5 cl. **gin**, 1/2 **grapefruit juice** (greyfurt suyu / saft), 1 bar sp. **sugar** (puder / powder / pudra), 1 cl. **soda - water syphon**.  
Decor - Garnish: 1/2 **tranch grapefruit** & 1 **cocktail cherry**.
- 201 **GREEN FIZZ (Sh.)**  
4 - 5 **ice**, 1 **white of egg**, 2 bar sp. **sugar syrup**, 1 **lemon juice** (saft / 1 limonun suyu), 5 cl. **gin**, 1 bar sp. **creme de mente green liqueur**, **soda - water** (syphon), decor:peppermint sprigs (nane yaprakları / pfefferminze / menthe (poivrée / menta, hierbabuena).
- 202  **ORANGE FIZZ (Sh.)**  
5 cl. **gin**, 1 **orange juice**, 1 bar sp. **sugar** (powdered / puder / pudra), 1 cl. **soda - water** (syphon), Decor - Garnish: 1/2 **tranch orange** & 1 **cocktail cherry**.
- 203 **PFEFFERMINZ FIZZ (Sh.)**  
2 cl. **vodka** (or **gin**), 3 cl. **menthe liqueur**, 2 bar sp. **sugar syrup** or **powdered sugar**, 1 1/4 - 5 **ice**, 1 **white of egg** (eiweiß / yumurta akı / blanc d'œuf / chiara d'uovo, albume / clara de huevo)  
1/2 **lemon juice** (saft / suyu) **soda - water** (syphon),  
decor:peppermint sprigs (nane yaprakları / pfefferminze / menthe (poivrée / menta, hierbabuena).
- 204 **TEXAS FIZZ (Sh.)**  
5 cl. **cin**, 1/2 **orange juice**, 1/2 **lemon juice**, 1 bar sp. **sugar**, 1 cl. **soda - water** (syphon / sifon), decor / garnish: 1/2 **tranche lemon** & 1 **cocktail cherry** (kokteyl kirazı).

### FLIPS / çabuk canlandırıcı

yumurta sarısı ile yapılan kokteyller / öğleden önce & çay saatinde this combination egg-nog & fizz is made with liqueur, eggs, sugar & shaken well with cracked ice (kırılmış buz) egg-nogg kategorisinden olup, süt kullanılmadan yapılan içkilendir.

**before lunch / fancy drinks / long drinks**

205

**BRANDY FLIP (Sh.)**

cracked ice (geschlagenem eis / kırılmış buzlar), 5 cl. brandy, (cognac), 1-2 bar sp. **sugar syrup** (şeker şurubu / zucker sirop), 1 **egg-yolk** (yolk of egg / eigelb / yumurta sarısı / rosso d'uovo, tuorlo / yema de huevo), **nutmeg** (muskatnuß / hint cevizi / (Noix de) muscade / muscat / Noce moscata / Nuez moscada), "shake yapıldıktan sonra flip bardağına süzülür üzerine nutmeg (misket hint cevizi) rendelenir."

206

**BOSTON FLIP (Sh.)**

1/2 rye whiskey, 1/2 madeira wine (madère / aperitif şarap), 1 **egg-yolk** (eigelb / yumurta sarısı), 1 bar sp. **sugar syrup** (sirop / şurup), **muscat** (nutmeg / hint cevizi) üzerine serpiniz.

207

**CHAMPAGNE FLIP (Sh.)**

4 cl. cognac, 1 cl. maraschino cherry liqueur, 1 **egg-yolk** (eigelb/ yumurta sarısı), 1 cl. **sugar syrup** (or powdered sugar / pudra şekeri), cracked ice, cold champagne, muscat (hint cevizi).



208

**DAMEN - HERREN FLIP (Sh.)**

4 cl. brandy, 4 cl. vermouth (white / weiß / bianco / beyaz), 2 bar sp. **sugar** (zucker / pudra şekeri), 1 **egg-yolk** (eigelb / yumurta sarısı), **muscat** (nutmeg / hint cevizi) üzerine serpiniz.

209

**MOCCA FLIP (Sh.)**

5 cl. crème de mocca liqueur (likör / licor), 1 bar sp. cream (sahne / rahm / krem şanti / crème fraiche / panna, ceram /Nata, crema), (or sugar), 1 **egg-yolk** (eigelb / yumurta sarısı), muscat (nutmeg / hint cevizi) üzerine serpiniz.



210

**PORTO FLIP (Sh.)**

5 cl. porto wine (fortified / porto / port / liman şarabı), 1 bar sp. sugar, 1 **egg-yolk** (eigelb / yumurta sarısı), **muscat** (nutmeg / hint cevizi) üzerine serpiniz.

211

**ROSÉ FLIP (Sh.)**







1/2 cherry brandy liqueur (likör / licor), 1/2 cherry juice (saft / suyu), 1 **egg-yolk** (eigelb / yumurta sarısı), **muscat** (nutmeg / hint cevizi) üzerine serpiniz.

212

**SHERRY FLIP (Sh.)**

5 cl. sherry wine (fortified / porto / port / liman şarabı), 2 bar sp. sugar, 1 **egg-yolk** (eigelb / yumurta sarısı), **muscat** (nutmeg / hint cevizi) üzerine serpiniz.



- 213  GIN (cin) & TONIC aperitif / long drink
- 214  GIN - BITTER LEMON long drink
- 215  GIN - CHERRY JUICE (vişne suyu) long drink
- 216  GIN - GRAPEFRUIT JUICE (greyfurt) long drink
- 217  GIN - MANDARIN JUICE long drink
- 218  GIN - COLA long drink
- 219  GIN - GRENADEAPPLE JUICE (nar) in season/ Barantico Spc.
- 220 GIN - MELON JUICE (kavun) in season/ Barantico Spc.
- 221 GIN - WATERMELON JUICE (karpuz) in season/ Barantico Spc.
- 222 GIN MENTHE direct in glass / direkt bardakta
- ice, gin, crème de menthe liqueur, soda - water (syphon),  
peppermint sprigs (nane yaprakları / pfefferminze /  
menthe (poivrée / menta, hierbabuena), tranche lemon  
(kesme limon).
- 223 GIMLET (Sh.) before dinner drink  
4 cl. gin, 3 bar sp. lemon juice (saft / suyu), 1 bar sp. sugar  
syrup, soda - water.
- 224 GIPSY (Sh.)  
2 ice, 3 cl. vodka, 2 cl. Benedictine D.O.M. liqueur (bitki  
likörü), 1 d. angostura or orange bitter (acı / amer (f.amère) /  
amaro / amargo).
- 225 GOLDEN GLEAM (Sh.)  
1/3 brandy, Grand Marnier (cognac & orange liqueur), lemon  
juice (saft / suyu), orange juice.
- 226 GOLDEN COCKTAIL (Sh.)  
3 - 4 ice, 1 bar sp. grenadine syrup, 1 bar sp. curaçao white  
likör, 2 cl. vermouthe rosso (red / rot / kırmızı), 2 cl. gin,  
1 cocktail cherry.
- 227 GOLDEN DAISY COCKTAIL (Sh.) or (mixer)  
2 - 3 ice cubes, 1 lemon juice, 1 cl. cointreau liqueur, 3 cl.  
whisky, 1 -2 bar sp. sugar syrup, "soda - water" fill up.
- 228 GOLDEN DREAM (Sh.)  
brandy, Grand Marnier liqueur, banana liqueur, orange juice  
(saft / suyu).
- 229 GOLDEN MONOPOLE (Sh.)  
1 cl. O'Darby Dairy Cream Irish liqueur, 1 d. peppermint white  
liqueur (pfefferminz weiß), 3 cl. orange juice (saft / suyu),  
champagne dry fill up, 4 x peppermint sprigs (nane yaprakla-

- 230 rı / pfefferminze / menthe (poivrée / menta, hierbabuena).  
**GOGEL - MOGEL** **tıbbi tavsiye / kahvaltıya**  
 1 **egg** (yumurta), **egg-yolk** (yolk of egg / eigelb / yumurta sarısı / rosso d'uovo, tuorlo / yema de huevo), 1 bar sp. **sugar syrup**, 6 cl. **brandy**, **nutmeg** (muskatnuß / hint cevizi / (Noix de) muscade / muscat / Noce moscata / Nuez moscada).
- 231 **GRAND MARNIER - TONIC**
- 232 **GREEN BURSA (Sh.)**  **Barantico Spc.**  
 mise en place / vorbereitung / ana hazırlık: Kesilmiş bir limon suyunu bardak ağzında (rand) gezdirerek bardak ağzını nemlendiriniz & toz şeker üzerinde hafifçe gezdirip şekerleyiniz. 6 cl. **mente liqueur**, 2 d. **banana liqueur**, 1 bar sp. **powder sugar** (pudra şekerı), 2 d. **gin** (cin), 2 cl. **cold milk** (milch / süt), fill up, decor / garnish: tranche green lemon or mandarin, 1 clove ( nelke - karanfil - clou de girofle - clove - chioda di garofano - elavo "de especia").
- 233 **GREEN DRAGON (Sh.)**  
 3 x ice, 5 cl. **vodka**, 5 cl. **crème de menthe green liqueur**, **peppermint sprigs** (nane yaprakları / pfefferminze / menthe (poivrée / menta, hierbabuena).
- 234 **GREEN SEA (Sh.)**  
 2 - 3 x ice, 1.5 cl. **French vermouthe dry**, 2 cl. **vodka**, 1.5 cl. **crème de menthe green liqueur**, **peppermint sprigs** (nane yaprakları / pfefferminze / menthe (poivrée / menta, hierbabuena).
- 235 **GREEN EYES**  
**mint liqueur** (likör / licor), **vodka**, **orangejuice** (saft / suyu).
- 236 **GREEN PEACE (Sh.)**  
 3 cl. **gin** (cin), 1 cl. **menthe liqueur**, 3 bar sp. **lemon juice** (saft / suyu), **white of egg** (eiweiß / yumurta akı / blanc d'œuf / chiara d'uovo, albume / clara de huevo), **peppermint sprigs** (nane yaprakları / pfefferminze / menthe (poivrée / menta, hierbabuena).  
**mint liqueur** (likör / licor), **vodka**, **orange juice** (saft / suyu).
- 237 **GREEN HAT**  
 2 / 3 ice, 2.5 cl. **gin**, 2.5 cl. **crème de menthe liqueur**, **soda - water**, decor/ garnish: **straw** (trinkhalm / strohhalm / pipette / chalumeau / paille).

- 238 **GREEN BANANA (Sh.)**  
3 cl. **BOLS Grüne banana**, 2 cl. **white rum** (weiß / beyaz),  
8 cl. **pineapple juice** (ananas saft / suyu), 2 cl. **Coconut Cream**,  
ice (eis / buz).
- 239 **GRÜNE WITWE** long drink  
ice (eis / buz), 1.5 cl. **gin** (cin), 1.5 cl. **mente liqueur** (likör /  
licor), 1.5 cl. **vermouth dry**, **peppermint sprigs** (nane yap-  
rakları / pfefferminze / menthe (poivrée / menta, hierbabuena).
- 240 **CRAZY THINK'S & LOVE / çılgın tutkular & aşk**  
**Afrodizyak özellikli** Barantico Spc.  
ice, 1 cl. **malibu** (hindistan cevizi sütlü rum), 2 cl. **gin**,  
2 cl. **tequila**, **cherry liqueur** (likör / licor), **cherryjuice** (saft / suyu).
- 241 **HAPPY BACARDI** direct in glass / direkt bardakta  
**long drink**  
**cracked ice** (zerstoßenes Eis / kırılmış buzlar), 2 cl. **Bacardi**  
**Carta Blanca**, 2 cl. **Bacardi Gold**, 2 cl. **Southern Comfort**, 5  
cl. **fresh orange juice** (taze / frisch / frais (f.fraîche) / fresco),  
2 cl. **fresh limett juice** (misket limon suyu / saft), 1 bar sp.  
**grenadine syrup**, 1 bar sp. **sugar syrup** (zucker sirop / şeker  
şurubu), decor / garnish: **peppermint sprigs** (nane yaprakları /  
pfefferminze / menthe (poivrée / menta, hierbabuena), cockta-  
ilcherry, tranche ananas & orange “auf den glasrand einen  
fruchtspieß mit cocktail cherry, ananas & orange - zweig freisc-  
her minze legen / kokteyl kirazını, nane yapraklarını tranche  
ananası & portakalı dizgi çubuğuna dizip bardağın ağzına  
koyunuz.
- 242 **HARMAN DALI (Sh.)** Prof.Dr.Sırmalı Cocktails  
Barantico Spc.  
**Tequila**, **green curaçao liqueur**, **cointreau liqueur**, **crème de**  
**mente liqueur**, **gin** (cin), **martini dry vermouth**, **Archer's peach**  
**schnaps**, 2 d. **lemon juice** (saft / suyu).
- 243 **HALF & HALF (Sh.)** before dinner drink  
2 x ice, 2.5 cl. **vermouth bianco** (weiß / beyaz), 2.5 cl.  
**grapefruit juice** (saft / suyu), 1 d. **campari bitter**  
(acı / amer (f.amère) / amaro / amargo).
- 244 **HARVEY WALLBANGER** long drink  
4 cl. **votka**, 2 cl. **Galliano liqueur** (likör / licor), **orange juice**  
fill up tranche orange.  
(Galliano konulmazsa **SCREWDRIVER** olur.)



Çok çabuk hazırlanabilen susuzluğu giderici, sodalı su & meyve sularından yapılan mütevazi içkilerdir.

245 **BOURBON HIGHBALL**

cracked ice (zerstoßenes Eis / kırılmış buzlar), 4 cl. **bourbon** whiskey, 2 d. **angostura bitter**, soda.

**HOT DRINKS / sıcak içkiler / hot beverages**

with & non alcoholic / mit & alkohol frei  
alkollü ve alkolsüz desserts / after dinners

246 **CAPPUCCINO**

Coffee (kaffee / kahve), **schaum milch** / kaynatılmış sütün köpüğü, **bitter chocolate** (bitter çikolata) “üzerine serpiniz”.

247 **CAFÉ CRÈME DE GRAND MARNIER**

4 cl. **crème de grand marnier**, coffee “fill up”.

248 **COFFEE OLATE**

2 cl. **rum** or (other / veya) **brandy**, coffee “fill up”.

249 **EXOTIC COFFEE**

**Barantico Spc. Prof.Dr.Sırmalı Cocktails**

1 cl. **Safari** (exotic african liqueur), **nescafé** or **filter coffee** fill up (to fill (up) / füllen (auf) / doldurunuz (üzerine) /remplir/ riempire)

250 **FRENCH COFFÉE**

3 cl. **Grand Marnier liqueur**, **filter** veya (or / oder) **nescafé**, **cream** (sahne / rahm / krem şanti / crème fraiche / panna, ceram / Nata, crema) “cream siphon”.

251 **FUROR BAVARICUS**

1/2 **lemon juice** (saft / suyu), 4 x **sugar cubes** (küp şeker / zucker), 7.5 cl. **hot milk**, 1/2 **egg-yolk** (yolk of egg / eigelb / yumurta sarısı / rosso d'uovo, tuorlo / yema de huevo).

252 **GROG**

3 - 4 cl. **rum** (or gin / whisky), 2 - 3 bar sp. **sugar**, juice of 1/2 **limon**, **hot water** fill up (to fill (up) / füllen (auf) / doldurunuz (üzerine) /remplir/ riempire), **tranche lemon** (slice / schiebe / schnitte / fetta, trancia / tranciol lonja/ tajada/kesme), **lemon peel** (schale / kabuk / pelure / buccia / cáscara), **clove** ( nelke - karanfil - clou de girofle - clove - chioda di garofano - elavo “de especia”), **cinnamon** (zimt / tarçın / canelle / canella / canela) service: bir cam çay kaşığı & alt tabak.



- 253 **HALB & HALB**  
1/2 **white wine**, 1/2 **red wine** (wein / şarap), 1 **cinnamon** (tarçın), 1 bar sp. **sugar** (zucker / şeker).
- 254 **HOLLAND COFFEE**  
2.5 cl. **advocaat BOLS egg liqueur** (“avukat” yumurta likörü), **coffee** (kahve / kaffee), 4-5 bar sp. **cream** (cream siphon), 1/2 bar sp. **coffee** & 1/2 bar sp. **cocoa** (üzerine serpiniz).
- 255 **IRISH COFFEE** (İrlanda kahvesi)  
**Hot coffee** with **Irish whiskey** (3-4 c.) & cream on top cream (sahne / rahm / krem şanti / crème fraiche / panna, ceram / Nata, crema) “**cream siphon**”, **bitter chocolate** (rendelenmiş bitter çikolata üzerine serpiniz.)
- 256 **LUMUMBA**  
**hot chocolate** with **rum** & **sugar** (rumlu çikolata “kakao” & şeker)
- 257 **MALIBU HOT CHOCALATE**  
4 cl. **malibu** (hindistan cevizi sütlü rum), **hot cocoa** fill up (to fill (up) / füllen (auf) / doldurunuz (üzerine) / remplir / riempire).
- 258 **MULLED WINE / mülled claret / sıcak şarap** in winter  
**red wine**, **fruit**, **cinnamon**, **cloves**, **sugar** (kırmızı şarap, meyveler, “elma, portakal, kuru üzüm, limon vs.” tarçın, karanfil, şeker)
- 259 **PHARISAER COFFEE**  
5 cl. **brown rum**, 3-4 bar sp. **sugar**, **coffee**, 4 - 6 bar sp. cream (cream siphon) **bitter chocolate**, üzerine serpiniz.
- 260 **TEA OLATE**  
2 cl. **rum** or **brandy**, **sugar** (şeker / zucker), **tranch lemon**.
- 261 **ICED TEA / buzlu çay**  
2/3 **tea** (tee / çay), 1 cl. **lemon juice** (saft/ suyu), 1/2 **juice of orange**, 2-3 bar sp. **sugar** (zucker / şeker), **tranche lemon**, **orange & lemon peel**. (limon kabuğu)  
service: iyice karıştırılıp, bir saat buzdolabında soğutmaya bırakıldıktan sonra.
- 262 **IPANEMA COCKTAIL (Sh.)** long drink  
**cracked ice** (gestoßenem Eis / kırılmış buzlar) 2 parts (Teile / bölüm) **Batida De Coco**, 2 parts (Teile / bölüm) **white rum** (weißer rum), 1 part (Teile / bölüm) **Rossantico**.
- 263 **JAMAICA DREAM**  
2 cl. **vodka**, 2 cl. **Tia Maria liqueur**, 2 cl. **cream**, 8 cl. **orange juice**, **pineapple juice** (Ananas saft / suyu).





- 264 **JUNGLE JUICE (Sh.)**  
3.5 cl. **Pisang Ambon** (exotic banana liqueur), 1.5 cl. dry **gin**  
1 cl **apricot brandy liqueur**, 3 drops of **lemon juice**, add fresh  
**orange juice**, **ice cubes**, cocktail cherry, 1/2 **tranche pineapple**  
(ananas) or **orange** (slice / scheibe / schnitte / fetta, trancia /  
tranciol lonja/ tajada/kesme)

### JULEPS / mint-juleps

nane yaprakları, şeker, su, bardağın içinde kaşık ile ezilip bol buzla içilen içkilerdir.

Native to Kentucky, juleps are cool & refreshing anywhere. Traditional'y made with Kentucky bourbon & fresh mint leaves & served in a frosted glass with a straw

(pippettes / strohhalm).

1 oz. (ounce)= ~ 3 cl./30 gr /ml.

### 265 a) MINT JULEP / southern style

ice, 4 x **peppermint** sprigs (nane yaprakları / pfefferminze menthe (poivrée / menta, hierbabuena), 1 bar sp. **powdered sugar** (puder zucker / pudra şeker), 2 bar sp. **water** (wasser /su), 2 1/2 oz (ounce) **bourbon whiskey**, decor garnish: 2 straws, mint sprigs.

### b) MINT JULEP

fancy drink

4-5 **ice cubes**, 1 bar sp. **sugar syrup** (or sugar), 5 cl.

**bourbon whiskey**, 2-3 dashes **angostura**, mint sprigs, 2 straws.

### 266 BRANDY JULEP



1 bar sp. **powdered sugar** (puder zucker / pudra şeker), 5 -6 leaves **fresh mint sprigs**, 2 1/2 oz **brandy**.

(eis & stir) decor / garnish: tranche pineapple (ananas), orange or lemon. 1 cocktailcherry, straws (strohhalm).

### 267 K - C 25 COCKTAIL (Der Kniekehlencocktail -1925 / diz altı kokteyl)



mise en place / vorbereitung / ön hazırlık: shaker veya mix glass yerine eti butuna dolgun bayan bacağı dizinden kıvrılır, dizaltında oluşan çanak biçimindeki yerde hazırlanır.

**vermouth**, 1 d. **champagne** (şampanya / sekt)

“istek üzerine” **straw** (trinkhalm / strohhalm /

pipette / chalumeau / paille).



- 268 **KAMIKAZE (Sh.)**  
1 oz. / ounce (yaklaşık 3 cl.) **lemon juice**, 1oz. Triple Sec **orange liqueur** (likör /licor), 1 oz. **vodka**.
- 269 **KANGAROO (Sh.)**  
2 cl. **curaçao orange liqueur**, 4 cl. **bacardi** (hindistan cevizli sütlü rum), 2 cl. **Batida de Coco**, 1 **lemon juice** (saft/ suyu), pineapple juice (ananas saft / suyu). fill up & ice.
- 270 **KEHRAUS**  
4 cl. **Fürst Bismarck** (sekt / champagne), 1/2 **juice of lemon**, **salt**, **pepper**, **red pepper** (tuz, biber, kırmızı biber) & **Tabasco** (Acisso), **tomatojuice** (domates suyu) fill up (to fill (up) / füllen (auf) / doldurunuz (üzerine) /remplir/ riempire)
- 271 **KIKU KIKU**  
2 **ice cubes**, 6 cl. **Sake** (“Kiku Masamune“ rise wine / Japon piriş şarabı, rakısı), 1 cl. **gin**, 3 cl. **pineapple juice** (ananas saft / suyu), **straw** (trinkhalm /strohalm / pipette chalumeau).
- 272  **KIRKANBAR / bekar bayıldı (Sh.)** **Barantico Spc.**  
2 cl. **gin**, 2 cl. **vodka**, 1 cl. **seville orange liqueur** (turunç) 1 1/2 **grapefruit juice** (greyfurt suyu / saft), 2 cl. **grenadine syrup** (nar şurubu), 2 bar sp. **sugar**, 1 d. **angostura bitter**, 1 bar sp. **cream** (krem şanti), 2 cl. **cold milk** (fill up), 2 d. **peach juice** (şeftali suyu), 2 **cinnamon** (tarçın), **clove**. (karanfil).
- 273 **KISS ME QUICK (Sh.)**  
4 cl. **Canadian whisky**, 2 d. **cointreau** (liqueur), 2 d. **angostura bitter**, 1 bar sp. **powdered sugar** (puder zucker / pudra şekeri)
- 274 **LADY (Sh.)**  
2/3 **Canadian whisky**, 1/3 **pineapple juice** (ananas saft / suyu) 2 dash **anisetite** (liqueur), 2 d. **angostura bitter**.
- 275 **LADY IN AMAZON (Sh.)**  
**bacardi rum**, **safari liqueur**, **blue curaçao liqueur**, **lemon juice** (saft / suyu), **orange juice**, **pineapple juice** (ananas saft / suyu).
- 276  **LARA**  
mise en place / vorbereitung / ön hazırlık:  
kesilmiş bir limonun suyunu bardak ağzında (rand) gezdirerek bardak ağzını nemlendiriniz & toz şeker üzerinde hafifçe gezdirip şekerleyiniz.



- 3 x ice cubes, 3 cl. vodka, 1 cl. curaao triple sec liqueur, 3 cl. lemon juice (saft / suyu), 1 d. grenadine syrup (nar řurubu / sirop), ginger ale lemonade (limonade / limonada / gazoz), fill up, 1/2 tranche orange, 2 pickled (ubuk) cocktail cherry.
- 277 LOVE HOME**  
vodka, gin, pineapple juice (ananas saft/suyu), grenadine syrup.
- 278**  **LOVE ELIXIR TO MAITE / ařk iksiri (Sh.)** Barantico Spc.  
4 cl. whisky, 2 cl. apricot brandy liqueur, 1 cl. Benedictine D.O.M. liqueur, 5 cl. orange juice (saft / suyu), 1 cl. grenadine syrup, cinnamon (zimt / tarın / canelle / canella / canela)
- 279 LONG ISLAND ICE TEA**  
bacardi rum, tequila, gin, Triple Sec liqueur, lemon juice (saft / suyu), cola.
- 280 a) MANHATTAN (Mg.)** classic & sweet cocktail  
2 - 3 ice, 2 / 3 Canadian Club whisky, 1.5 cl. vermouth bianco  
1 cl. French vermouth, 1 d. angostura bitter, 1 cocktail cherry, lemon peel (schale / kabuk / pelure / buccia / cscara).  
**b) MANHATTAN (Mg.)** classic & dry cocktail  
2 - 3 ice, 4 cl. Canadian Club Whisky, 1 cl. vermouth dry,  
1 cl. angostura bitter, 1 cocktail cherry or lemon peel.  
(whisky yerine gin konulursa MARTINI DRY. olur.)
- 281 a) MARGARITA (Mix.) or (Sh.)** classic & medium cocktail  
aptiritif  
mise en place / vorbereitung / n hazırlık:  
kesilmiř bir limonun suyunu bardak ađzında (rand) gezdirerek bardak ađzını nemlendiriniz & tuz zerinde hafife gezdirip tuzlayınız.  
5 cl. tequila (tekila), 2.5 cl. curaao triple sec or cointreau liqueur, 2.5 cl. lemon juice (saft / suyu).  
**b) MARGARITA**  
tequila, triple sec liqueur, lime juice (misket limonu suyu).
- 282 MARY OF SCOTLAND (Sh.)**  
mise en place / vorbereitung / n hazırlık:  
kesilmiř bir limonun suyunu bardak ađzında (rand) gezdirerek bardak ađzını nemlendiriniz & řeker zerinde hafife gezdirip řekerleyiniz.  
3 - 4 ice, 2 cl. scotch whisky, 1.5 cl. drambuie whisky liqueur,  
1.5 cl. Chartreuse Green liqueur, 1 cocktail cherry.

- 283 **MASCOTTE (Sh.)**  
2 / 3 French vermouth, 1 / 6 anisette (Französischer Anislikör Fransız anason likörü), 1 / 6 Bénédictiné D.O.M. (bitki likörü).
- 284 **MALIBU TONIC** **direct in glass / direkt bardakta**  
**long drink**  
ice, 4 cl. malibu (hindistan cevizi sütlü rum), tonic (tonik), tranche lemon (slice / scheibe / schnitte / fetta, trancia / tranciol lonja/ tajada/kesme).
- 285 **MALIBU BITTER LEMON** **direct in glass / direkt bardakta**  
**long drink**  
mise en place / vorbereitung / ön hazırlık:  
Kesilmiş bir limon suyunu bardak ağzında (rand) gezdirerek bardak ağzını nemlendiriniz & tuz üzerinde hafifçe gezdirip tuzlayınız.  
ice, 4 cl. malibu, bitter lemon, tranche lemon.
- 286 **MALIBU ORANGE** **direct in glass / direkt bardakta**  
**long drink**  
ice, 4 cl. malibu, orange juice (saft / suyu), tranche orange.
- 287 **MALIBU COLA** **direct in glass / direkt bardakta**  
**long drink**  
ice, 4 cl. malibu, cola.
- 288 **MALIBU WITH MILK**  
ice, 4 cl. malibu, cold milk (soğuk süt), decor / garnish: 1 straw (trinkhalm / strohhalm / pipette / chalumeau / paille), 1 strawberry (erdbeere / çilek / fraise).
- 289 **MALIBU** **"on the rocks"**  
ice, 4 cl. malibu, tranche lemon.
- 290 **MARABA COCKTAIL (Sh.)** **long drink**  
2 parts (teile / bölümler) white rum, 1 part batida tropical, dashes of grenadine syrup, 1 cocktail cherry (kokteyl kirazı).
- 291 **MARTINI** **"on the rocks"**  
4 - 5 ice, 4 - 5 cl. gin, 1 - 3 dashes vermouth extra dry, tranche lemon, olive (zeytin) mise en place: "önceden zeytini limon suyuna yatırınız."
- 292 **MARTINI EXTRA DRY & BITTER ORANGE** **long drink**
- 293 **MARTINI ROSSO & COLA** **long drink**
- 294 **MARTINI BIANCO & TONIC**



- 295 **MERRY WIDOW / şen dul (Sh.)**  
2 cl. vodka, 2 cl. cointreau (likör), 1 cl. grapefruit juice.
- 296 **MILANO - PARIS** aperitif  
4 cl. campari bitter, 1 cl. pernod (french rakı), ice, water or soda - water, "fill up".  
birne schnaps (schnapps), 1 cl. Curaçao blue liqueur, snow ice (schnee Eis / kar buz), decor / garnish: tranche peach (şeftali), 2 green cocktail cherries, mint sprigs, 2 straws.
- 297 **MÜNCHEN - BURSA LINE** direct in glass / Barantico Spc.  
ice, 3 cl. peach brandy liqueur (şeftali likörü), 1 cl. williams birne schnaps (schnapps), 1 cl. Curaçao blue liqueur, snow ice (schnee Eis / kar buz), decor / garnish: tranche peach (şeftali), 2 green cocktail cherries, mint sprigs, 2 straws.
- 298 **MOMO (Sh.)** Barantico Spc.  
ice, 3 cl. tequila gold, 2 cl. redorange BOLS, 2 cl. fresh lemon juice, decor / garnish: tranche pineapple (ananas).
- 299 **MONT BLANC (Sh.)**  
3 x ice, 1.5 cl. gin, 2 cl. cointreau liqueur, 1.5 cl. cream, 1 bar sp. sugar, pipette (straw).
- 300 **MORNING GLORY (Sh.)**  
1/2 cherry brandy liqueur, 1/3 cognac, 2 d. curaçao "white" liqueur, 2 d. angostura, 1 olive (zeytin) "zeytini önceden limon suyuna yatırınız."
- 301 **MYRA COCKTAIL (Mg.)** before dinner drink  
2 - 3 ice, 2.5 cl. red wine, 1.5 cl. vodka, 1 cl. vermouth dry.

### MARTINI & gibson cocktails

the classical / klasikler

always pour the gin first then the vermouth. / daima mix glass içine cin vermuttan önce konulur. The original martini recipe called for half dry gin & half dry vermouth. / orijinal martini reçetesi 1/2 gin, 1/2 vermouth dry olurdu.  
**mise en place/ vorbereitung/ ön hazırlık:**

yeşil zeytin önceden limon suyuna yatırılacak, martini kadehi önceden buz ile soğutulacak. Grüne oliven vorher, in Zitronen saft einlegen, ein vorgekühltes / martini glas forberieten

temel reçete / recipe / rezept:  
apéritifs / cold glass



302

**a) MARTINI USA type (Mg.)**

dry cocktail

4 cl. gin, 1 bar sp. vermouth dry, 1 d. orange bitter, lemon peel (spiral limon kabuğu), 1 olive (zeytin).

**b) MARTINI DRY (Mg.)**

classic cocktail

3 ice cubes, 4 cl. dry gin, 1 cl. martini vermouth extra dry, 1 d. angostura bitter, 1 d. orange bitter, 1 olive (zeytin) or lemon peel (schale / kabuk / pelure / buccia / cáscara).

(gin yerine whisky konulursa MANHATTAN olur.)

**c) MARTINI VERY DRY (Mg.)**

1/1 gin, 1 bar sp. vermouth extra dry, 1 olive (zeytin).

**d) DRY MARTINI COCKTAIL (Mg.)**

3/4 gin, 1/4 dry martini vermouth, twist of lemon or an olive.

(stir on broken ice & strain or serve "on the rocks".)

**e) SWEET MARTINI COCKTAIL (Mg.)**

2/3 gin, 1/3 sweet martini vermouth, 1 cocktail cherry.

(stir on broken ice & strain).

**f) MARTINI SWEET (Mg.)**

medium cocktail

1/3 gin, 2/3 vermouth, 1 d. grenadine syrup, 1 cocktail cherry.

**g) MARTINI MEDIUM (Mg.)**

3 cl gin, 1 cl. vermouth dry., 1 cl. vermouth red, 1 d.

angostura bitter, lemon peel (spiral limon kabuğu),

1 olive (zeytin).

**h) MARTINI ENGLISH type (Mg.)**

3 cl gin, 3 cl. vermouth dry (or sweet), 1 d. orange bitter,

orange peel, 1 olive (or cocktail cherry).

**i) MARTINI COCKTAIL DRY (Mg.)**

dry. gin, martini extra dry, angostura, orange bitter, olive.



303

**MARTINI-STEINHÄGER (Mg.)**

2 cl. Italian vermouth dry., 4 cl. Steinhäger (kornschnaps),

1 dash (spritzer / fişkırtı) orange bitter, olive (zeytin).

(gerührt mit eis / buz ile karıştırınız).

304

**MALTINI (Mg.)**

4 cl. malteserkreuz Aquavit (sprits) martini dry. vermouth,

1 cocktail onion (pearl onion / perlzwiebel / inci soğan).

305

**FIFTY - FIFTY (Mg.)**

3 cl. gin, 3 cl. vermouth extra dry, 1 green olive.



- 306 **GIBSON (Mg.)** dry & aperitif  
2/3 gin, 1/3 vermouth, 1 d. angostura, 1 d. orange bitter.  
1 cocktail onion (pearl onion / perlzwiebel / inci soğan).
- 307 **VODKA GIBSON (Mg.)** dry & aperitif  
3 ice cubes, 4 cl. vodka, 1 cl. vermouth dry, 3 pickled onions.
- 308 **VODKATINI (Mg.)**  
1/1 vodka, 1 bar sp. vermouth dry., 2 d. angostura bitter,  
1 cocktail onion (pearl onion / perlzwiebel / inci soğan).
- 309 **a) NEGRONI (Mg.)** aperitif "dry & classic cocktail"  
3 ice cubes. 2 cl. gin, 2 bar sp. campari (bitter), 2 bar sp. vermouth rosso (red / rot / kırmızı), "allongé", soda - water, fill up, tranche orange, 1 straw (trinkhalm / strohhalm / pipette / chalumeau / paille).  
**b) NEGRONI (Mg.)**  
1/3 gin, 1/3 sweet vermouth, 1/3 campari bitter, soda - water (optional), slice of orange (tranche portakal).  
**c) NEGRONI (Mg.)**  
gin, campari bitter, martini rosso, orange juice (saft / suyu).
- 310 **NELSON (Sh.)**  
2/3 gin, 1/6 Benedictine D.O.M. liqueur, 1/6 Maraschino-cherry liqueur (balkan bölgesinde Maraschino kasabasında yetişen kiraz).
- 311 **NEW ORLEANS (Sh.)**  
vodka, Blue Curaçao liqueur, tonic (tonik), grenadine syrup.

### NON ALCOHOLIC COCKTAILS / alkohol frei cocktails

alkolsüz kokteyller

oto sürücülerine tavsiyemiz: fancy drinks

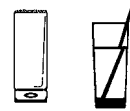





- 312 **ADIDAS DRINK (Sh.)** after game  
2 cl. mandarin syrup, 8 cl. orange juice, 1 egg-yolk (yolk of egg / eigelb / yumurta sarısı / rosso d'uovo, tuorlo / yema de huevo), tranche orange, 1 cocktail cherry.
- 313 **BALLERINA**  
4 bar sp. lemon juice, 4 bar sp. orange juice, 4 bar sp. pineapple juice (ananas saft / suyu)

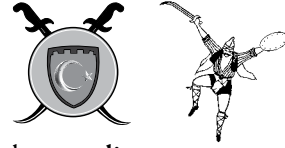

- 314 **BANANA - FLIP (Mix.)**  
2 ice cubes, 1/8 l. milk, 2 cl. créam, 1 white of egg (eiweiß / yumurta akı / blanc d'œuf / chiara d'uovo, albume / clara de huevo), tranche banana, spiral lemon peel, 2 -4 bar sp. sugar.
- 315 **BANANA - MIX (Mix.)** **tıbbi tavsiye**  
1/8 l. milk, 2 whites of egg, 2 bar sp. cream (sahne / rahm / krem şanti / crème fraîche / panna, ceram / Nata, crema), 1/2 banana (muz), 1 bar sp. sugar, spiral lemon peel, 2 ice.
- 316 **BOBBY (Sh.)**  
1 1/2 cream, 1/4 lemon juice, 1/4 orange juice, 1 bar sp. sugar.
- 317 **BURSA - SWORD & SHIELD COCKTAIL (Sh.)**  
Bursa - kılıç & kalkan kokteyl  
mise en place / vorbereitung / ön hazırlık:  
bardak ağzı şekerlenilecek.  
peach - apricot - orange - grapefruit juice, 2 cl. grenadine syrup, 1 bar sp. cream, 1 bar sp. honey (bal), 1 clove (nelke - karanfil - clou de girofle - clove - chioda di garofano - elavo "de especia"), cinnamon (zimt / tarçın / canelle / canela / canela), 1 pumpkin sugar (kürbis zucker / kabak şekeri) or green cocktail cherry, 2 straws (trinkhalme / pipettes).
- 318 **CARO AS (Mix.)**  
2 carrots (karotten / havuç), 1/4 ayran (buttermilk / yoghurt drink), salt (salz / tuz), sugar (zucker / şeker), pepper, parsley (petersilien / maydanoz / persillées / prezzemolo / perejil).
- 319 **CHAPALA**  
1/8 l. orange juice, 2 bar sp. grenadine syrup, salt, cayennepepper, parsley. (petersilien / maydanoz / persillées /prezzemolo /perejil).
- 320 **COCO KISS (Sh.)**  
pineapple juice (ananas suyu), orange juice, cream, coconut.
- 321 **CREOLE - COOLER (Sh.)**  
pineapple juice (ananas suyu), orange juice milk (milch / süt).
- 322 **EVRİMİM (Mix.)** **Prof.Dr. Sırmalı cocktails in season / sezonunda**  
5 cl. cold milk, 8 x strawberry (erdbeer / çilek / fraise), 2 bar sp. Coco Tara cream, 1 bar sp. powder sugar (puder zucker / pudra şekeri), 1 cl. apple juice (apfel saft / elma suyu).









- 323 **FLORIDA - FLIP (Sh.)**  
orange juice, grenadine syrup, 1 white of egg, soda -water, (fill up), nutmeg (muskatnuß / hint cevizi / (Noix de) muscade / muscat / Noce moscata / Nuez moscada).
- 324 **FLORIDA (Sh.)**  
orange juice, lemon juice, 2 d. angostura bitter, 2 cocktail cherries.
- 325  **FRUIT COCKTAIL (Sh.)** **Barantico Spc.**  
peach - cherry - orange - pineapple - grapefruit juice.  
(şeftali - vişne - portakal - ananas - greylurt suları).
- 326 **4 FRUIT COCKTAIL (Sh.)**  
lemon - grapefruit - orange - pineapple juice.
- 327 **GESUNDHEIT - çok yaşa (Mix.)**  
2 carrots (Karotte / havuç / carottes / carote / zanahorias),  
1/4 l. ayran (buttermilk / yoghurt drink), salt (salz / tuz),  
sugar (zucker / şeker).
- 328  **GRAPEFRUIT - HIGHBALL**  
2-3 ice cubes, 2.5 cl. grenadine syrup, 7.5 cl. grapefruit juice,  
 soda - water (or lemonade), straw (trinkhalm / strohhalm / pipette / chalumeau / paille).
- 329 **GRENADINE - LIMONADE**  
2-3 ice cubes, 5 cl. grenadine syrup, soda - water, 1 lemon juice, straw (trinkhalm / strohhalm / pipette / chalumeau)
- 330 **KIRKANBAR / bekar bayıldı (Sh.)** **Barantico Spc.**  
1 1/2 grapefruit juice (greylurt suyu), 2 d. grenadine syrup,  
2 bar sp. sugar (zucker / şeker), 1 d. angostura bitter, 1 bar sp. cream, 2 cl. cold milk, 2 d. peach juice, 2 clove (karanfil),  
cinnamon (tarçın).
- 331 **LEMONMILK (Mg.)**  
2 - 3 ice, 2.5 cl. grenadine syrup, 15 cl. cold milk, 2.5 cl. lemon juice.
- 332 **MIAMI (Sh.)**  
lemon - grapefruit - orange juice, grenadine syrup,  
1 d. angostura bitter.
- 333 **NAPOLI**  
grapefruit juice, grenadine syrup, tonic, pineapple juice.
- 334  **PUSSY CAT (Sh.)** **tropical drink**  
orange juice, grapefruit juice, grenadine syrup, pineapple juice.  
(portakal - greylurt suyu, nar şurubu, ananas suyu).

- 335 **PICCOLO - FLIP (Sh.)** **Barantico Spc.**  
 1 orange juice, 1/2 lemon juice, 1 grapefruit juice, 2 d. apple juice, 1 white of egg, 2 barsp. cream, 4 d. grenadine syrup, 1 d. angostura bitter, muscat (nutmeg / hint cevizi).  
 üzerine serpimiz.
- 336 **SPEZI / şpeti** **long drink / highball**  
 1/2 cola, 1/2 orange juice (saft / suyu), 1 tranche lemon.
- 337 **ULUDAĞ (Sh.)** **Barantico Spc.**  
 1/2 cold milk, 1/2 grapefruit juice, 2 bar sp. sugar, 1 green cocktail cherry, 4 bar sp. cream, cinnamon (tarçın)
- 338 **VIRGIN MARY (Mg.)**  
 ice, salt & pepper (tuz & biber), tabasco (acıso), worchestershire sauce, tomato juice (domates suyu / saft) (vodka konulursa BLOODY MARY olur.)

non alcoholic cocktails / mocktails with MONIN

- 339 **EMERAUDE (Sh.)**  
 2 cl. lime syrup (sirop de citron vert), 2 cl. peach syrup (sirop de pêche), 2 cl. blue curacao syrup (sirop de curaçao bleu), tranche lemon, 3 x cocktail cherries.  
 (fill up with tonic - water serve over ice).
- 340 **EXOTIC BLUE (Sh.)**  
 4 cl. BOLS blue curaçao, 2 cl. cream (sahne / krem şanti), 8 cl. pineapple juice (ananas saft / suyu).
- 341  **FIZZY FIRE (Sh.)**  
 2 cl. orgeat (almond / badem / sirop d'orgeat), 2 cl. grenadine syrup (sirop de grenadine), 2 cl. lemon juice (jus de citron), 6 cl. orange juice (jus d'orange), 1/4 tranche orange & lemon.  
 (fill up with lemonade / allonger de limonade).
- 342 **GREEN SUMMER (Sh.)**  
 4 cl. BOLS grüne banana, 4 cl. pineapple juice (ananas saft / suyu), bitter lemon (fill up / auffüllen / üzerine doldurunuz).
- 343 **GRÜNE WITWE (Sh.)**  
 4 cl. BOLS blue curaçao, orange juice “fill up” (saft / suyu / auf eis mit orangen saft auffüllen / buz üstüne portakal suyuyla doldurunuz), “tranche portakalı long drink bardağı üzerine yerleştirip, ortasından pipett'i geçiriniz”.

- 344 **GRÜNSCHNABEL (Sh.)**  
4 cl. **BOLS grüne banane**, ice (eis / buz), **orange juice** (saft / suyu), (fill up / auffüllen / üzerine doldurunuz).
- 345 **KENTUMI (Mix.)**  
8 cl. **passion fruit syrup** (sirop de passion), 1 **scoop of vanilla ice cream** (1 boule de glace à la vanille), 2 cl. **lime syrup** (jus de citron vert), **soda - water or lemonade** “fill up”, decor / garnish strawberry (erdbeer / çilek / fraises / fragole /fresas), tranche lemon.
- 346  **LIBERTINE (Sh.)**  
mise en place / vorbereitung / ön hazırlık:  
 kesilmiş bir limonun suyunu bardak ağzında (rand) gezdirerek bardak ağzını nemlendiriniz & toz şeker üzerinde hafifçe gezdirip şekerleyiniz.
-  4 cl. **rose syrup** (sirop de rose), 4 cl. **passion fruit syrup**, (sirop de passion), 2 cl. **coconut syrup** (sirop de coco), 2 cl. **cherry syrup** (sirop de cerise), (fill up with soda - water / allonger d'eau gazeuse), decor: 2 x pickled cherries, fruits.
- 347 **PUFFO (Sh.)**  
2 cl. **blue curacao syrup** (sirop de curaçao bleu), 2 cl. **coconut syrup** (sirop de coco), 4 cl. **lemon juice** (jus de citron), pineapple juice “fill up” 1 straw (trinkhalm / strohhalm / pipette / chalumeau / paille).
- 348 **SUMMER GARDEN (Sh.)**  
2 cl. **orgeat** (almond / badem) syrup (sirop d'orgeat), 2 cl. **strawberry (çilek) syrup** (sirop de fraise), 2 cl. **raspberry syrup** (sirop de framboise), 2 cl. **black currant syrup** (sirop de cassis) “redcurrant (johannisbeer / groseilles / ribes / grosellas)”, 2 cl. **blackberry syrup** (sirop de mûre), 10 cl. **apple juice** (jus de pomme / elma suyu), decor: 1/2 apple, 1 strawberry (erdbeer / çilek).
- 349 **SWEET DREAMS (Sh.)**  
2 cl. orgeat (almond / badem) syrup (sirop d'orgeat), 2 cl. strawberry (çilek) syrup (sirop de fraise), 2 cl. milk (milch / süt) (fill up with soda - water).

350

**OLD FASHIONED**after dinner /dry  
cocktail / classic

direct in glass / direkt bardakta

1 **sugar cube** (zucker / şeker), 1 bar sp. **sugar**, 4 d. **angostura bitter** (top of sugar / kesme şekerin üzerine damlatınız), 5 cl. **bourbon whiskey**, 1/2 **tranche orange & lemon**, 3 - 4 **cocktail cherry**, 1 **ice**, 2 d. **soda - water**.

(whisky yerine gin konulursa **OLD FASHIONED-GIN** olur.)

351

**OLYMPIA (Sh.)**

1 cl. **aperol** (bitter & sweet + oranjen aroma % 11), 3 cl. **gin**, 1 cl. **lemon juice** (zitronensaft /limon suyu), 1 bar sp. **sugar syrup**, 1 **cocktail cherry**, **ice cubes**.

352

**OLYMPIC (Sh.)**

2 cl. **cognac** (french brandy / fransız brendisi), 1 cl. **cointreau liqueur** (likör / liqueur / licor), 2 cl. **lemon juice** (saft / suyu), 1 **cocktail cherry** (kokteyl kirazı/cocktailkirsche).

(brandy yerine gin konulursa **WHITE LADY** olur.)

353

**a) ONE EXCITING NIGHT (Sh.)**

mise en place / vorbereitung / ön hazırlık:  
kesilmiş bir limonun suyunu bardak ağzında (rand) gezdirerek bardak ağzını nemlendiriniz & toz şeker üzerinde hafifçe gezdirip şekerleyiniz.

2 - 3 **ice cubes**, 1.5 cl. **dry. gin**, 1.5 cl. **french vermouth dry**, 1.5 cl. **vermouth bianco** (white / weiß / beyaz), 1 bar sp. **orange juice**, **lemon peel** (schale / kabuk / pelure / buccia / cáscara).

**b) ONE EXCITING NIGHTS****orange juice**, **dry vermouth**, **sweet vermouth**, **gin**.

354

**OPERA (Sh.)**

short drink

3 cl. **gin** (cin), 1 cl. **dubonnet bitter**, 1 cl. **mandarine liqueur**, spiral of orange tranche "komquat / kamkat" (zeytin büyüklüğünde oranj renkli turunç).

**OYSTERS**



mise en place / vorbereitung / ön hazırlık:  
şampanya kadehine zeytinyağı koyup kadehte gezdiriniz.

355

**GIN OYSTER**

1 barsp. **gin**, 1 **white of egg**, 2 barsp. **ketçap**, 1 d. **worchestershire sauce**, dash **lemon juice**, **pepper**, **paprika** (red pepper).





- 356 **INDIANA OYSTER**  
3 cl. **tomato ketchup** (ketçap), 1/2 cl. **brandy**, **red pepper**, **pepper**, **salt** (iyice karıştırınız), 1 **egg-yolk** (yolk of egg / eigelb / yumurta sarısı / rosso d'uovo, tuorlo / yema de huevo).  
(yumurta sarısını yavaşça üzerine bırakınız & karıştırmayınız, bir kerede yutunuz, afiyet olsun.)
- 357  **a) PARADISE (Sh.)** **medium cocktail**  
3 cl. **gin**, 1 cl. **apricot brandy liqueur**, 1 cl. **orange juice** (saft/ suyu), a **slice of apricot** (tranche).
-  **b) PARADISE (Sh.)**  
**lemon juice**, **orange juice**, **gin**, **apricot brandy liqueur**.
- 358 **PARAMISE**  
**bacardi rum**, **amaretto di saronno** (acı badem likörü / afrodisyak özellikli), **orange juice** (saft / suyu).
- 359 **PEMBE RÜYA (Sh.)** **orient style**  
4 cl. **orange liqueur**, 2 cl. **crème de rosé liqueur**, 1 cl. **gin** (cin).
- 360 **PERFECT (Mg.)** **cold glass**  
1/3 **gin**, 1/3 **Italy vermouht**, 1/3 **French vermouht**, 1/2 **trance orange**.
- 361 **PINK GIN (Mg.)** **before dinner drink**  
3-4 **ice**, 5 cl. **gin**, 2-3 dashes **angostura** (aromatic bitter), d. **grenadine syrup**, d. **soda - water**.
- 362 **PINK NIGHT** **Prof.Dr.Sırmalı cocktails / Barantico Spc.**  
4 cl. **gin**, 3 cl. **lemon juice** (saft / suyu), 1 cl. **grenadine syrup**, 1 cl. **coconut**.
- 363 **a) PINK LADY (Sh.)** **"medium cocktail / short drink"**  
2 cl. **gin**, 2 cl. **grenadine syrup**, 2 cl. **lemon juice**, **calvados** (apple brandy).  
(grenadine yerine blue curaçao konulursa **BLUE LADY** olur.)
-  **b) PINK LADY**  
**gin**, **lemon juice**, **sugar**, **white egg**.
- 364 **PINK PEARL (Sh.)** **before dinner drink**  
3-4 **ice**, 6 cl. **gin**, **grapefruit juice**, 1 cl. **lemon juice**, 1 cl. **grenadine syrup**, 1 Tbl. sp. **white of egg**.

- 365 **PIMMS NO. 1**  
1/2 gin, lemonade (red or white), tranche lemon & orange & cucumber (hıyar/gurke), swizzle stick & straws, sprig of mint “nane yaprakları”, 12 oz. / ounce worthington or highball glass over ice cubes. Serve straight or garnished.
- 366 **PINK ROSÉ (Sh.)**  
2/3 gin, 1 bar sp. cream, 1 bar sp. lemon juice, 1 bar sp. grenadine syrup (sirup / şurup / sirop / sciroppo / jarabe), 1 white of egg (eiweiß / yumurta akı / blanc d’œuf / chiara d’uovo, albume / clara de huevo).
- 367 **PLUIE D’OR (Sh.)**  
1/2 gin, 1/4 Vieille cure, 1/8 orange juice, 1/8 caraway (-seed) (kümmel / kimyon / cumin / cumino / comino).
- 368 **a) PRESIDENT (Sh.)**  
2/3 bacardi rum, 1/3 orange juice, 2 d. grenadine.  
**b) PRESIDENT (Sh.)**  
3-4 ice, 2.5 cl. vermouth dry, spiral orange.
- 369  **PRESIDENTE**  
ice, 3/4 bacardi rum, 1/4 vermouth dry, 1/2 bar sp.grenadine (Amerikalılar bu içkiye 1/2 d. curaçao koyarlar.)
- 370 **PRINCE CHARLIE (Sh.)**  
1/3 cognac (french brandy), 1/3 drambuie (whisky liqueur / viski likörü), 1/3 lemon juice (saft / suyu).
- 371 **PROF’S GIN** Prof.Dr.Sırmalı cocktails / long drink  
4 cl. gin, 2 cl. tonic - water, 2 cl. lemon juice, 2 d. angostura, 2 d. tabasco sauce (acisso), a slice of lemon & a cocktail cherry.

### PICK ME UPS

yorgunluğa karşı yeniden kuvvet toplayıcı içkiler

- 372  **MATRIOWSKA (Mg.)** or direct in glass / direkt bardakta  
5 cl. vodka, 2 d. worchestershire sauce, 3 drops tabasco, 1/2 lemon juice(1/2 limonun suyu), tomato juice, celery salt (kereviz tuzu / sellerie salz), “Céleris / Sedani / Apio” tranche cucumber (hıyar / gurken).  
(BLOODY MARY benzeridir, farkı: kalem hıyar & tuz yerine kereviz tuzu.)

- 373  **BLOODY MARY (Mg.)** aperitif & long drink  
3-4 ice cubes, salt & pepper, 1 d. tabasco (acisso), 1 d. worchesteshire sauce, 3 - 4 cl. vodka, 1 bar sp. lemon juice, 6 cl. tomato juice, tranche lemon.
- 374  **GRAND MARNIER PICK ME UP (Sh.)** before dinner drink  
2 ice, 1.5 cl. orange juice, 2.5 cl. Grand Marnier liqueur, champagne (fill up), pipette (straw).

### POUSSE - CAFÉS / rainbow cocktails

These sweet, striped wonders are made from a series of liqueurs poured in succession so that one floats on top of another. Follow the recipes exactly to get the layers of ingredients in the right order. Orijinal pouosse - café (rainbow cocktail) ufak kadehinde direkt olarak içkinin özgül ağırlığı / yoğunluğuna göre bar kaşığı tersinden veya içinden bardak iç kenarına dayayarak yavaşça dökünüz.  
after dinners / cream cocktails / sweet drinks / fancy drinks

#### direct in glass - direkt kadehte

- 375  **ANGEL'S DELIGHT**  
with bar spoon: 1 1/2 bar sp. grenadine syrup, 1 1/2 bar sp. Triple Sec liqueur, 1 1/2 bar sp. Sloe Gin, 1 1/2 bar sp. light cream (sahne / krem şanti).
- 376 **TURKISH DELIGHT / TÜRK LOKUMU** Barantico Spc.  
with bar spoon: 1 1/2 bar sp. mocca liqueur (kahve / kaffee likörü), rose liqueur (crème de rosé / gül likörü), light cream (sahne / krem şanti).
- 377 **ANGEL KISS**  
with bar spoon: (1.) 3.5 cl. apricot brandy liqueur (likör / liquore/ licor), (2.) 1.5 cl. cream (sahne / rahm / krem şanti / crème fraiche/ panna, ceram/ nata, crema), 1 cocktail cherry (kokteyl kirazı / cocktailkirshce).
- 378 **B-52"**  
with bar spoon: (1.) 1.5 cl. Tia Maria liqueur, (2.) 1.5 cl. Irish Bailey's cream, (3.) 1.5 cl. Grand Marnier liqueur.
- 379 **B-62"**  
with bar spoon: kahlua, Bailey's liqueur, Grand Marnier liqueur, bacardi rum.

- 380 **EIERMÄNNCHEN**  
with bar spoon: (1.) **cherry liqueur** (kiraz likörü), (2.) **egg liqueur** (yumurta likörü).
- 381 **FINNLANDIA**  
with bar spoon: (1.) **grenadine syrup**, (2.) **menthe green liqueur**, (3.) 1 bar sp. **maraschino liqueur**, (4.) 1 bar sp. **curaçao blue liqueur**.
- 382 **GRASSHOPPER / çekirge**  
with bar spoon: 2. cl. **crème de cacao**, 2.5 cl. **crème de menthe green, cream**.
- 383 **JUNGBRUNEN**  
with bar spoon: **egg liqueur**, **crème de menthe green liqueur**, **cherry brandy liqueur** (likör).
- 384 **MARIA TERESA**  
with bar spoon: 3 cl. **Archer's**, 3 cl. **blue curaçao liqueur**, 5 cl. **orange juice** (saft / suyu).
- 385 **POUSSE-CAFÉ**  
with bar spoon: **grenadine syrup**, **maraschino cherry liqueur**, **crem  de menthe green liqueur**, **blue curaçao liqueur**, **brandy**.

## PUNCHES

Perfect for gatherings, punches can be mixed in endless varieties. Punch usulünde bowl cam kap içinde hazırlanırlar. Orijinalinde rum ile limon veya portakal suyu & şeker ilavesiyle hazırlanılan hem sıcak hem de soğuk olarak içilebilen kolay

hazırlanan bir içkidir.

**cold or hot / kalt oder warm / soğuk veya sıcak**

**long drinks / party drinks**

- 386 **ASBACH - PUNCH** **hot drinks**  
2 cl. **asbach uralt brandy** (Hugo Asbach), 2 bar sp. **sugar** (toz şeker veya pudra şekeri) 1 spiral **lemon Peel** (kabuk), 2 **cloves** (nelke / karanfil), (dikkatlice ısıtıp karıştırınız/ service: 1 punch glass (red wine glass) & 1 glass spoon (cam kaşık / glas löffel).
- 387 **BUDDHA - PUNCH** **party drinks / cold drink**  
20 cl. **red wine**, 15 cl. **orange juice** (saft / suyu), 15 cl. **lemon juice** (saft / suyu), 5 cl. **orange liqueur**, 5 cl. **dark rum**, 5 - 10 dashes **angostura bitter**, 40 cl. **soda - water**, 1 bottle **champagne, fruit, mint sprigs** (nane yaprakları / pfefferminze).





- 388 CLARED - PUNCH** party drinks / cold drink  
2 x juice of lemon, sugar (zucker / şeker), 3 bottles red wine, 25 cl. orange liqueur, 25 cl. brandy, 1 l. soda - water, fruit, ice cubes (buzlar).
- 389 HOT RUM - PUNCH** hot drinks  
5/8 dark rum, 1/8 brandy, 1/8 Bénédictine D.O.M. (bitki likörü), 1/8 kümmel (likör), 1 - 2 barsp. sugar, hot water.
- 390 PLANTERS - PUNCH** direct in glass / exotic long drink  
2 - 3 ice, 5 cl. white rum, 1/2 lemon juice, 2 bar sp. sugar syrup, 2.5 cl. orange juice, 2 -3 ice, decor / garnish: fruits (obst / meyveler), 1 cocktail cherry, d. grenadine syrup, soda-water.
- 391 POSTDAMMER - PUNCH** hot drinks  
2 bar sp. sugar, 1/8 hot water (sıcak su ısıtarak karıştırınız), 1 glass white wine dry (kaynatmadan ısıtınız), 6.1 cl. brown rum, 1/4 juice of lemon, 1 spiral lemon peel.  
service: punch kadehi, 1 cam çay kaşığı (istenilirse yaz içkisi olarak hazırlanabilir, soğutmaya bırakıldıktan sonra 2 saat buzdolabında soğutmaya bırakılır, yanına çıtır veya kuru pasta ile ikram edilir.)
- 392 RED KISS (Mg.)** before dinner drink  
2 - 3 ice, 3 cl. French vermouth dry, 1 cl. gin, 1 cl. cherry brandy liqueur, spiral lemon peel (spiral limon kabuğu).
- 393 RED LION (Sn.)** after dinner  
2 cl. gin, 2 cl. Grand Marnier liqueur, 1 cl. orange juice (saft / suyu), 1 cl. lemon juice.
- 394 RED TONIC**  
ice, 3 cl. grenadine syrup, 3 cl. vodka, 1 cl. lemon juice, tonic - water.
- 395 ROB ROY (Mg.)** medium cocktail  
5 cl. whiskey, 1 cl. vermouth, 2 d. angostura bitter.
- 396 ROLLS ROYCE** on the rocks / before dinner  
2 - 3 ice, 2.5 cl. gin, 1.5 cl. French vermouth dry, 1 cl. vermouth bianco, 1 - 2 Bénédictine D.O.M. liqueur, 1 cocktail cherry.



397  **ROSÉE (Sh.)** cold glass

mise en place / vorbereitung/ ön hazırlık:  
bardak ağzı şekerlenecek.

4 cl. **gin**, 2 cl. **lemon juice**, 2 cl. **rose syrup** (Sirop de Rose),  
ice (eis / buz), **tranche lemon**.

398 **a) ROSÉ (Sh.)** cold glass

mise en place: bardak ağzı şekerlenecek.

1/4 **vermouth**, 1/4 **grenadine syrup**, 1/2 **cherry juice**, 1  
**cocktail cherry**.



**b) ROSÉ COCKTAIL (Mg.)** cold glass

mise en place: bardak ağzı şekerlenecek.

3 x **ice**, 1 d. **grenadine syrup**, 1 cl. **apricot brandy liqueur**,  
1 cl. **French vermouth dry.**, 3 cl. **gin**, 1 **cocktail cherry**.

399 **ROC - A - COE**

**gin**, **cherry brandy liqueur**, 1 **cocktail cherry** (kokteyl kira-  
zı/cocktailkirsche).

400 **ROYAL (Sh.)**



1/3 **gin**, 1/3 **French vermouth**, 1/3 **sherry brandy liqueur**,  
**maraschino cherry liqueur** (likör).

401 **SELİN (Sh.)** S.Serpen cocktail long drink / fancy



2 cl. **Gordon's gin**, 2 cl. **malibu**, 2 cl. **Archer's**, 2 cl. **lemon  
juice** (suyu), 4-6 cl. **orange juice** (sıkma portakal suyu), **tranche  
orange**, **cocktail cherry** (kokteyl kirazı)

### RICKEYS (refreshing / erfrishend / tazeleyici, ferahlatici)

A cross between a collins & a sour, rickeys are always made with lime, cracked  
ice, & a carbonated beverage.

genelde serinlemek için içilen uzun içkilerdir. Alkol, limon suyu , kırık buz &  
soda tamamlanarak içilirler.

402 **GIN RICKEY** long drinks

4 cl. **gin**, 1/2 **lemon juice**, **soda - water**, **ice**, **tranche lemon**.

403 **RUM RICKEY** long drinks





1/2 **lime juice**, 1 1/2 oz./ounce (- 4.5 cl. "45 gr. / ml.") **light  
rum**, **ice cubes**, **carbonated water** (fill up & stir).

404 **SANTOS COCKTAIL (Sh.)** long drinks

3x **ices**, 1 part (teil / bölüm) **Batida de Café**, 1 part **Italian  
brandy**, 1 part **creme - cacao liqueur**.



- 405 **SAFARI ADVENTURE (Sh.)** **Barantico Spc.**  
2 cl. safari Africian liqueur, 1 cl. maraschino cherry liqueur,  
2 cl. bacardi rum, 2 cl. vodka, 4 cl. orange juice, tranche kiwi,  
tranche orange, 1 cocktail cherry.
- 406 **SCORPION**  
gin, tequila, vodka, Triple Sec liqueur, orange juice.
- 407 **SEA SUN SEX**  
blue curaçao, apricot-orange juices, bindallı likör (seville orange).
- 408 **SEXY PICCOLO (Sh.)** **Barantico Spc. / erotic**  
afrodizyak özellikli **mise en place / vorbereitung / ön hazırlık:**  
**bardak ağzı şekerlenilecek.**  
2 cl. gin, 2. cl. vodka (or / oder / veya) rum, 1.cl. orange  
liqueur, 1 1/2 grapefruit juice (greyfurt saft / suyu), 2 d.  
grenadine syrup, 2 bar sp. sugar (zucker / şeker), 1 d. angostura  
bitter, cinnamon (zimt / tarçın / canelle / canella / canela),  
clove (nelke - karanfil - clou de girofle - clove -  
chioda di garofano - elavo "de especia").
- 409 **SEX ON THE BEACH**  
4 cl.vodka, 2cl. Archer's, 2 dashes grenadine syrup,  
fill up (üzerine doldurunuz.) orange juice.
- 410 **SHANGHAI (Sh.)**  
1/2 rum, 1/4 lemon juice, 1/4 anisette (anis / anason) liqueur,  
2 d. grenadine syrup.
- 411  **SHAKERATO (Sh.)**  
4 cl. aperol, dash (spritzer / fişkirtı) limett or orange juice,  
ice cubes.
- 412 **a) SIDE CAR (Sh.)** **classic & medium cocktail**  
2 - 3 ice, 3 cl. cognac (French brandy), 1 cl. cointreau  
liqueur, 2 cl. lemon juice, 1 cocktail cherry.  
(brandy yerine gin konulursa **WHITE LADY** olur.)  
**b) SIDE CAR (Sh.)** **classic & medium cocktail**  
1/2 cognac, 1/4 cointreau (liqueur / likör), 1/4 lemon juice.
- 413 **SILVER (Sh.)**  
1/2 gin, 1/2 French vermouht, 1 d. orange bitter, 2 d.  
maraschino cherry liqueur, white of egg  
(eiweiß / yumurta akı /blanc d'œuf / chiara d'uovo,  
albume / clara de huevo).



- 414 **SINGAPORE SONG**  
Gordon's gin, brandy, lemon juice, mineral - water.
- 415 **SNOWBALL**  
ice, 1/2 advocaat liqueur, d. lemon juice, white lemonade,  
"fill up", tranche orange, cherry, straw (pipette).
- 416  **SONJA COCKTAIL (Sh.)**  
2.5 cl. vodka, 2.5 cl. menthe liqueur, peppermint sprigs (na-  
ne yaprakları / pfefferminze / menthe (poivrée / menta, hierba-  
buena).
- 417 **SPIRIT OF SCOTLAND (Sh.) -- direct in glass / direkt bardakta**  
ices, 4 cl. Dewar's White Label whisky, 2 cl. Drambuie Prince  
Charles Edward's Liqueur, 1 cl. fresh (taze / frisch / frais  
(f.fraîche) / fresco) lemon juice (zitronensaft / limon suyu), 1/2  
(half / halbe / yarım), tranche lemon.
- 418 **SKY DIVER (Sh.)** Prof.Dr.Sırmalı cocktails  
3 cl. gin, 2 cl. blue curaçao liqueur, 2 cl. malibu rum, 3 cl.  
tonic - water. fill up.
- 419 **STANLEY (Sh.)**  
1/2 gin, 1/2 bacardi rum, 1 d. grenadine syrup, 1 d. lemon juice.
- 420 **STAR (Sh.)** short drink / before dinner drink  
2 cl. vermouth red, 1 cl. brandy, 2 cl. orange juice, ice, 2-3  
cocktail cherries, 2 cl. champagne. fill up.
- 421 **STINGER (Sh.)** after dinner sweet cocktail / classic cocktail  
1/2 crème de mente blanch liqueur, 1/2 cognac (brandy).
- 422 **SULTAN COCKTAIL** Barantico Spc.  
direct in glass / direkt bardakta  
4 cl. vodka, fig juice or syrup (konserve incir suyu veya  
şurubu), decor / garnish: 1 fig (incir).
- 423 **SWEET LADY (Sh.)** after dinner drink / afrodisyak  
1.5 cl. whisky, 2 cl. crème de cacao liqueur, 1.5 cl. peach  
brandy liqueur.
- 424 **SWEET LOVE (Sh.)**  
8 cl. gin, 1 cl. lime syrup (Sirop de Citron Vert), 1cl.  
grenadine syrup, ice, 2 tranche lemon.

## SANGRIA & PARTY DRINKS

- 425 **MALIBU SUNSET** wellcome drinks  
5 cl. malibu, grenadine syrup, orange juice, pineapple juice (ananas saft / suyu), 1 cocktail cherry, 1 tranche orange, 1 straw (pipette / strohhalme).
- 426 **SANGRIA** fancy drinks / wellcome drinks  
10 cl. red wine, 2 cl. brandy, 2 cl. orange liqueur, 2 bar sp. sugar, tranche lemon, ice & a little soda - water.

## SANGAREES

These are taller, sweet old-fashioned without bitters.

- 427  **BRANDY SANGAREE**  
1/2 bar sp. powdered sugar (puder zucker / pudra şekeri), 1 .bar sp. water (wasser / su), 2 oz./ounce (6 cl.) brandy, ice cubes, fill up with carbonated water. stir, nutmeg (muscat / hint cevizi).
- 428  **GIN SANGAREE**  
1/2 bar sp. powdered sugar, 1 bar sp. water, 2 oz./ounce gin, carbonated water, 1 tbsp. (eßlöffel / yemek kaşığı), port, nutmeg (muscat / hint cevizi).

## SLINGS

These are like sangarees, but made with the addition of lemon juice & a twist of lemon peel. / Sling'ler Rickey'ler gibi soda ile tamamlanan uzun içkilerdir.

long drinks

- 429 **GIN SLING (Sh.)**  
4 cl. gin, 1/2 lemon juice, 2 bar sp. grenadine syrup (nar şurubu), soda - water (fill up), ice, tranche lemon, 1 cocktailcherry.
- 430  **a) SINGAPORE SLING (Sh.)**  
5 cl. gin, 1.5 cl. lemon juice, 1.5 cl. orange juice, 2. cl. cherry brandy liqueur, grenadine syrup, 2 d. angostura bitter, 1 bar sp. sugar syrup, 1 cocktail cherry, tranche lemon, soda - water fill up.
- b) SINGAPORE SLING (Sh.)**  
4 cl. gin, 2 cl. cherry brandy liqueur, 1/2 lemon juice, soda - water fill up, ice, decor / garnish: tranche lemon or orange, mint sprigs (nane yaprakları / pfefferminze)

## SMASHES

These are junior - sized juleps.

colins & juleps arası içkilendir, daha az hacimlidirler.

mise en place / vorbereitung / ön hazırlık: direct in glass / direkt bardakta julepslerde olduğu gibi bir bar kaşığı ile toz şekeri & nane yaprakları biraz su ile ezilir.

### 431 BRANDY SMASH

4 cl. **brandy** (or / oder / veya gin, whisky, rum), 1 bar sp. **powdered sugar** (puder zucker / pudra şekeri), **mint sprigs**, a little **water** (wasser / su), **soda - water**, **ice**, decor / garnish: mint sprigs, tranche orange.

### SOURS / ekşiler (refreshing / erfrishend / tazeleyici)

Fizzlere benzerler, küçük hacimlidirler, limon suyu, şeker veya şurubu & birkaç damla yumurta akıyla hazırlanırlar.

medium cocktails / fancy drinks

### 432 ASBACH SOUR (Sh.) Ein erfrischender drink

4 cl. **Asbach Uralt German brandy** (Weinbrenner / damıtımcı, destille eden Hugo Asbach), 4 cl. **fresh lemon juice** (taze / frisch / frais (f.fraîche) / fresco), 2 cl. **fresh orange juice** (saft / suyu), 2 cl. **sugar syrup** (zuckersirup “läuterzucker”), **ice cubes**, **cocktail cherry**, **tranche orange**, **soda-water**, (siphon). (tekrar soda ilave edilirse **LONG DRINK** olur.)

### 433 BRANDY SOUR (Sh.) classic cocktail / medium cocktail

5 cl. **brandy**, 1/2 **lemon juice**, 2 bar sp. **sugar**, 2 **cocktail cherries**, **tranche orange**, **soda - water** (siphon / sifon).

### 434 GIN SOUR (Sh.)

5 cl. **gin**, 1/2 **lemon juice**, 2 bar sp. **sugar**, 2 **cocktail cherries**, **tranche orange**, 1 cl. **soda - water** (siphon / sifon).

### 435 GUILLOME SOUR (Sh.)

2 **ice**, 1 bar sp. **sugar syrup**, 1/2 **lemon juice**, 4 cl. **scotch whisky**, 2 bar sp. **soda - water**, 3 **cocktail cherries**, **straw**.

### 436 RUM SOUR (Sh.) classic cocktail & tropical

3 - 4 **ice**, 4 cl. **white rum**, 1 cl. **golden rum**, 2 bar sp. **sugar or syrup**, 2 cl. **lemon juice**, **cocktail cherry**, **soda-water** (siphon / sifon).

437 **SCOTCH SOUR (Sh.)**  
4 cl. Bell's scotch whisky, 4 cl. lemon juice, 2 cl. sugar syrup (or powder sugar), 1/4 tranche orange, 1 cocktail cherry, 1 - 2 d. soda - water (siphon / sifon).

438  **VODKA SOUR (Sh.)**  
5 cl. vodka, 1/2 lemon juice, 2 bar sp. sugar, 2 cocktail cherries, tranche orange, soda - water (siphon / sifon).

### SWIZZLES

These drinks originally came from the West Indies where a swizzle stick was a twig having three to five forked branches on the end.



439 **GIN SWIZZLEE (Sh.)**  
juice of 1 lime (misket limonu), 1 bar sp. powdered sugar (pu-der zucker / pudra şekerı), 2 oz. / ounce (~ 6 cl. / 60 gr. / ml.), carbonated water (gazlı su) "siphon", ice & stir (üzerine buz koyup stir'leyin. decor: swizzle stick.  
(gin yerine brandy konulursa **BRANDY SWIZZLE** olur.)  
(gin yerine whisky konulursa **WHISKY SWIZZLE** olur.)

440 **TANGO COCKTAIL (Sh.)** before dinner drink  
2 - 3 ice cubes, 1.5 cl. gin, 1.5 cl. vermouth red, 1.5 cl. curaçao orange liqueur, 1 cl. orange or lemon juice, orange or lemon peel (schale / kabuk)+crash ice / eis / buz.

441 **TAKE TWO (Sh.)**  
3 ice cubes, 2.5 cl. dry gin, 1.5 cl. orange juice (saft / suyu), 1 cl. campari bitter.

442 a) **TEQUILA SUNRISE (Mix. or in glass)** long drink  
4 cl. tequila, 2 cl. crème de cassis liqueur (johannesbeer / black red currants likör) "or grenadine syrup", 2 cl. lemon juice, "or orange juice", soda - water fill up 1 straw (pipette).

b) **TEQUILA SUNRISE** direct in glass / direkt bardakta  
ice (filled glass), 1/4 tequila (tekila), 3/4 fresh orange juice, 2 dashes grenadine syrup (stir & add. Splash in grenadine).

c) **TEQUILA SUNRISE** direct in glass / direkt bardakta  
tequila, orange juice (portakal suyu), lemon juice (limon suyu), grenadine syrup (sirup / şurup / sirop / sciroppo / jarabe).



- 443 **TEXAS (Mg.)**  
1/1 gin (cin), 1 d. grenadine syrup, 1 d. orange juice, 1 d. lemon juice. (limon suyu / saft).
- 444 **THE DIRTY HARRY** long drink / Harry's New York Bar  
4 cl. British Navy Pusser's rum, 1 - 2 cl. maple syrup, juice of 1 / 2 lime, apple juice (elma suyu).  
(hot or cold - depending on the weather)
- 445 **THE HARRIKIRI (Sh.)**  
4 cl. sake (japan rice wine / japon pirinç şarabı), 2 cl. Galliano (vanille basis likör) dash of blue curaço liqueur, juice of 1/4 lime, tonic -water (fill up), 1 cocktail cherry & a slice of lemon.
- 446 **TULIP (Sh.)**  
1 / 3 apple brandy liqueur, 1 / 3 Italian vermouthe, 1/6 apricot brandy liqueur (or apple brandy), 1/6 lemon juice.

### TODDIES

These may be served either hot or cold / sıcak veya soğuk içilebilen karışık içkilendir, sıcak içilenleri üşütme veya benzeri durumlarda tercih edilir.

direct in glass / direkt bardakta

- 447 **BRANDY TODDIE (cold / kalt / soğuk)**  
4 cl. brandy, 1 bar sp. sugar (zucker / şeker), water & ice.
- 448 **BRANDY TODDIE (hot / heiß / sıcak)**  
4 cl. (brandy, whisky or rum), 1 bar sp. sugar (toz şeker), kümmel (caraway & anise seeds likör) 2 cloves (nelke / karanfil), tranche lemon, hot water (fill up), kümmel sprigs.

### TROPICAL COCKTAILS / EXOTIC DRINKS

- 449 **BANANA DAIQUIRI (Sh.)**  
4 cl. rum, 2 bar sp. orange juice (saft / suyu), 2 bar sp. sugar maraschino cherry liqueur (likör, licor), tranche banana (slice / scheibe / schnitte / fetta, trancia / tranciol lonja/ tajada/kesme)
- 450 **BETWEEN THE SHEETS (Sh.)** medium cocktails / cold glass  
3 - 4 ice cubes , 2 cl. white rum, 2 cl. brandy, 2 cl. Triple Sec orange liqueur, 2 cl. lemon juice.

- 451  a) **BLUE HAWAII (Sh.)**  
bacardi white rum, curaço blue liqueur, lemon juice, tranhce pineapple (ananas).
- b) **BLUE HAWAII (Sh.)**  
Malibu, blue curaço liqueur, lemon juice, pineapple juice, (ananas saft / suyu).





**c) BLUE HAWAII (Sh.)**

4 cl. **white rum** (Rhum blanc), 1 cl. **Blue Curaçao Syrup** (Sirop Curaçao Bleu) 1 cl. **Frosted Mint Syrup** (Sirop de Menthe Glaciale), straw (pipette / trinkhalm).(Fill up with tonic - water serve over crushed ice / Allonger de Tonic Servir sur glace pilée / tonik ile doldurup, kırılmış buzlar ile servis yapınız.)

- 452 **COLOMBUS COCKTAIL (Sh.)** **cold glass (glas)**  
cracked ice, 4 cl. **golden rum**, 2 cl. **apricot brandy liqueur**,  
1 **limett** or **lemon juice**.

- 453  **DAIQUIRI (Sh.)** **classic cocktail & long drink**  
mise en place / vorbereitung / ön hazırlık:  
bardak ağzı şekerlenilecek. / glass rant mit zucker  
2/3 **rum**, 1/3 **lemon juice**, 1 bar sp. **sugar**, 1 bar sp. **grenadine syrup**, **tranche lemon**, 1 **cocktail cherry**.

- 454 **EL DIABLO** **exotic long drink**  
**tequila**, **Crème de Cassis liqueur**, **lemon juice**, **Ginger ale lemonade** (limonade / limonata / citronnade / limonada / gazoz).

- 455 **EXOTIC BLUE (Sh.)** **long drink**  
**ices**, 4 cl. **BOLS Blue Curaçao**, 2 cl. **cream** (sahne / rahm / krem şanti / crème fraiche / panna, ceram / Nata, crema),  
8 cl. **pine-apple juice** (ananas saft / suyu).

- 456 **FIESTA** **exotic long drink**  
**Captain Morgan rum**, **apricot brandy liqueur**,  
**grenadine syrup**, **lemon juice**, **orange juice**.

- 457 **FIREBALL** **direct in glass / direkt bardakta / long drink**  
**ices**, 3 cl. **BOLS Red Orange**, 2 cl. **gin** (cin), **tonic - water fill up / auffüllen / üzerine doldurunuz**.

- 458  **a) HAWAIIAN COCKTAIL (Sh.)**  
2 cl. **Crème de Banane liqueur**, 2 cl. **malibu**, 6 cl. **orange juice**,  
2 - 3 d. **curaçao blue liqueur** (likör).

**b) HAWAII COCKTAIL**

**malibu**, **bacardi rum**, **curaçao**, **pineapple juice** (ananas saft/suyu)

**c) HAWAIIAN**

**gin**, **orange juice**, **curaçao orange liqueur** (likör).



459 **MAI TAI (Mai Tai-Roa Ae / Tahiti) (Sh.)** long drink  
(RUM yerine VOTKA kullanılırsa CİCHI olur.)

cracked ice, 2.5 cl. white rum, 4 cl. brown rum, 4 cl.  
orange juice, 2 cl. curaçao orange. 2 cl. ananas juice  
2 cl. lemon juice, 2 cl. sugar syrup, 1 tranche limette,  
1 Minzweig / nane dalı

460 **a) PIÑA COLADA (Sh.)** exotic long drink / fancy drink



cracked ice, 5 cl. malibu (hindistan cevizi sütlü rum), pineapple  
juice (ananas saft / suyu), 1 - 2 dashes bitter lemon, coconut  
cream liqueur (hindistan cevizi likörü) or cream, milk, straw.

**b) PIÑA COLADA (Mixer)**



8 cl. Coconut Syrup (Sirop de Coco), 8 cl. white rum (Rhum  
blanc), 8 cl. lemon juice (jus de citron), 16 cl. Pineapple Juice  
(jus d'ananas), 1/2 tranche pineapple (ananas).

“Serve over ice / servir avec glaçons”

**c) PIÑA COLADA (blender)**

1/4 white rum (usually bacardi), 1/2 pineapple juice (ananas  
saft / suyu), 1/4 coconut milk or a substitute e.g. malibu,  
2 scoops crushed ice, tranche ananas, cocktail cherry, 2 short  
straws (2 kısa pipette).

**d) PIÑA COLADA**

non alcoholic sauce, bacardi rum, malibu rum, banana liqueur,  
pineapple juice (ananas saft / suyu), milk (milch / süt).

461 **SIR WALTER COCKTAIL (Sh.)** cold glass

cracked ice, 2 cl. golden rum, 2 cl. brandy, 1 cl. Triple Sec  
liqueur, 1 cl. grenadine syrup, 1/2 limett or lemon juice.

466 **WELCOME IN RED (Sh.)**



ice, 4 cl. BOLS Red Orange, 4 cl. Mango juice (saft / suyu),  
8 cl. orange juice (saft / suyu)

(im shaker zubereiten & über Eis im Weinglas servieren /  
shaker'de hazırlayıp buz üstüne şarap kadehinde servis ediniz.)

**SUGAR SYRUP / ZUCKER SIRUP / ŞEKER ŞURUBU**

**mise en place / vorbereitung / ön hazırlık:**



Wenn Sie einen Teil Zucker in einem Teil heißen Wassers  
auflösen, erhalten Sie Zuckersirup.

sıcak su ile şekeri eritiniz, şeker şurubunu elde ediniz.



- 467 **UP - TO - DATE** before dinner drink  
whisky, vermouth (wermut / vermuth / vermut), Grand Marnier  
liqueur.
- 468 **ULUDAĞ COCKTAIL (Sh.)** Barantico Spc.  
Mise en place / vorbereitung / ön hazırlık:  
bardak ağzı şekerlenecek / glass rant wird gezuckert  
3 cl. **gin** (cin), 1 cl. **vodka** (or rum), 1 cl. **orange** liqueur,  
1/2 **grapefruit** juice (saft / suyu), 5 bar sp. **cream** (sahne /  
rahm / krem şanti / crème fraiche / panna, ceram / Nata,  
crema), 1 tranche **grapefruit**, **cinnamon** (zimt / tarçın / canelle /  
canella / canela), **clove** ( nelke - karanfil - clou de girofle - clove  
- chioda di garofano - elavo “de especia”).
- 469 **VALENCIA (Sh.)** short drink / medium cocktail  
1.5 cl. **apricot** brandy liqueur, 2 cl. **orange** juice, 1.5 cl.  
**orange** bitter, **orange** peel (schale / kabuk / pelure / buccia /  
cáscara).
- 470 **VODKA CHERRY JUICE** votka vişne suyu - long drink
- 471 **VODKA GRAPEFRUIT JUICE** votka greyfurt suyu - long drink
- 472 **VODKA GRENADEAPPLE JUICE** votka nar suyu Barantico Spc.
- 473 **VODKA COLA** long drink
- 474 **VODKA LEMON** long drink
- 475 **VODKA & TONIC** long drink
- 476 **VODKA TOMATO JUICE / votka domates suyu** long drink
- 477 **VODKA MELON JUICE / votka kavun suyu** Barantico Spc.  
(yanına extra olarak içine önceden şırınga ile votka basılmış &  
soğutulmuş kavun, jülyen olarak kesilip kokteyl kirazı ile  
karışık servis edilir.)
- 478 **VODKA WATERMELON JUICE** Barantico Spc.  
Votka karpuz suyu
- 479 **WEDDING (Sh.)**  
1/4 **gin**, 1/4 **Dubonnet** (bitter / aperitif), 1/4 **cherry** brandy  
liqueur, 1/4 **orange** juice.
- 480  **a) WHITE LADY (Sh.)** medium / short drink / classic cocktail  
2 cl. **gin**, 2 cl. **cointreau** liqueur, 2 cl. **lemon** juice (extra 1 bar  
sp. or 1/2 white of egg), **cocktail** cherry.  
(gin yerine **cognac** (brandy) konulursa **SIDE CAR** olur.)  
(tequila konulursa **MARGARITA** olur, fark; kadeh ağzı tuzlu.)





- b) **WHITE LADY (Sh.)** **cold glass / vorgekühlte glass**  
 1/2 cl. gin, 1/4 lemon juice, 1/4 cointreau liqueur, 1 dash  
 egg white (1 spritzer / fişkirtı yumurta akı).
- 481 **WHITE LILY (Sh.)**  
 1/3 gin, 1/3 rum 1/3 cointreau liqueur, 1 d. anisette liqueur  
 (aniseed / anis / anason / anice ).
- 482 **WHITE NUN (Sh.)** **cold glass**  
 1/2 gin, 1/4 crème de menthe blanche liqueur, 1/4 cream.
- 483 **WHITE WING (Sh.)**  
 1/2 calvados, 1/2 crème de menthe blanche liqueur.
- 484 **WHICNOWSCI (Sh.)** **Prof.Dr.Şahin Sırmalı cocktail**  
 4 cl. vodka, 4 cl. fresh cherry juice, 1 cl. maraschino cherry  
 liqueur, cracked ice.
- 485 **WHISKY COCKTAIL (Sh.) or (Mg.)**  
 5 cl. whisky, 2 d. grenadine syrup, 2 d. angostura bitter.  
 (grenadine yerine curaçao veya şeker şurubu kullanabilirsiniz.)
- 486 **WHISKEY TWIST (Mg.)**  
 ice, 4 cl. Irish whiskey, 1 cl. lemon juice, 1 barsp. cherry  
 brandy liqueur, 1 bar sp. raspberry syrup (fromboises / himbeer)  
 cocktailcherry.
- 487 **WHITE CITY (Sh.)**  
 ice, 3 cl. coconut cream, 5 cl. cream (sahne / krem şanti), 1 cl.  
 lemon juice, 8 cl. pineapple juice (ananas suyu), decor: 1 tb.sp.  
 cream (geschlagene sahne).
- 488 **WOLGA WOLGA (Mg.)** **short drink**  
 4 cl. vodka, 1 cl. curaçao blue liqueur, 1 d. pernod  
 (french rakı).
- 489 **WHISKY "on the rocks" / on ice / auf eis / buz üstü**
- 490 **WHISKEY "on the rocks" / on ice / auf eis / buz üstü**
- 491 **WHISKY COLA**
- 492 **WHISKY SODA**

**ŞARAP / WINE / WEIN COCKTAILS**





- 493 **GESPRITZ / geşiprits**  
 white wine (beyaz şarap), cold soda - water.  
 (lütfen! 35 cl.lik beyaz şarap açınız.)



- 494 **KIR** **mexican style / aperitif / direct in glass**  
1 cl. or bar sp. **creme de cassis** liqueur (red currants / johannesbeer), **wine** (wein / şarap) üzerine doldurunuz.  
(şarap yerine şampanya konulursa **KIR ROYAL** olur.)
- 495 **WINE SPRITZER** **direct in glass / direkt bardakta**  
**ice - filled glass**, 1/2 dry. **white wine**, 1/2 **soda**, **twist of lemon**  
(optional).
- 496 **YELLOW BIRD (Sh.)** **long drink**  
3 cl. **brown rum**, 2 cl. **white rum**, 1 cl. **Tia Maria liqueur**, 4 cl. **orange juice**, 2 cl. **lemon juice**, 2 cl. **limett juice**,  
**cocktailcherry**, **mint sprigs** (minzezweig / nane yaprakları)  
**cracked ice**(Crash - eis).
- 497 **YELLOW SUBMARINE (Mg.)** **before dinner drink**  
2 - 3 **ice**, d. **angostura bitter**, 1.5 cl. **Dubonnet bitter**, 1.5 cl.  
**French vermouth dry**, 2 cl. **gin**.
- 498 **ZABAZAP - ULUDAĞ (blender)** **Barantico Spc. / in winter**  
 **spirits** (tuvalet ispiertosu), 1 **lemon** (with lemons peel / kabuğu ile)  
1 **orange with peel**, 1 **apple** (with peel / kabuğu ile),  
% 40 **quincejuice** (ayva suyu) 1 **parsley** (eine bündell petersilien  
/ 1 demet maydanoz), **cinnamon** (zimt / tarçın / canelle / canella  
/ canela), **clove** (nelke - karanfil - clou de girofle - clove - chioda  
di garofano - elavo "de especia")  
(hazırlandıktan sonra saç kap ile kar içine gömüp 10 saat  
bekletip servis ediniz. Kar içinde bekletilmezse  
kokteylin tadını alamazsınız!)
- 499 **ZEYBEK (Sh.)** **orient style / şark stili**  
2 cl. **gin**, 2 cl. **crème de menthe** liqueur, 2 cl. **crème de rosé**  
liqueur (gül likörü).
- 500 **ZOOM (Sh.)**  
2 - 3 **ice cubes**, 4 cl. **brandy**, 1.5 cl. **honey** (honig / bal / miel  
/ miele) **cream** (sahne / rahm / krem şanti / crème fraiche  
/ panna, cream / Nata, crema).
- 501  **a) ZOMBIE (Sh.)** **fancy drink**  
**ice**, **bacardi rum**, **myers rum**, **lemon juice**, **orange juice**, **Grand**  
**Marnier**, **lime juice**, **grenadine syrup**.+ **crash - eis**.  
**b) ZOMBI (Sh.)**  
**ice cubes**, **bacardi rum**, **apricot brandy liqueur**, **peach juice**  
(şeftali suyu), **orange juice**, +**crash - eis** (cracked eis, kırılmış buz)

## İLAVELER / EXTRA COCKTAILS

- 502 **COOL TOUCH (Sh.)** Barantico Spc.  
4 cl. Bacardi, 2 cl. lemon juice, 1 cl. sugar syrup, 1 cl. ananas saft / suyu, 1 cl. menthe liqueur.  
decor / garnish: Mint sprigs (taze nane yaprakları).
- 503 **KEHRİBAR (Sh.)** Barantico Spc.  
3 cl. Bacardi, 3 cl. Kahlua Mocca Liqueur, 0.5 cl. Amaretto di Saranno (acı badem likörü), 0.5 Cointreau Liqueur  
decor / garnish: lemon & orange peel
- 504 **ORGASM (Sh.)** Special Cocktails / long drink / Barantico Spc.  
2 cl. whisky, 4 cl. Bacardi, 4 cl. Blue Curaçao Liqueur, 2 cl. Archer's Peach Liqueur fill up lemonade (gazoz), dashes vodka, (Smirnoff), pippette.
- 505 **PANTY REMOVER (Sh.)** Anfora Rest. Spc.  
2 cl. vodka, 2 cl. Gordon Gin, 2 cl. white rum, 2 cl. Tequila (white), 2 cl. Cointreau liqueur, 1 cl. lemon juice, 1 cl. sugar syrup, 1 cl. cola (fill up / auf füllen / üzerine doldurunuz)  
tranche pineapple, green cocktailcherries
- 506  **ROYAL HIGHLAND TEA (Mg.)** Barantico Spc. / long drink  
2 cl. vodka, 2 cl. gin, 2 cl. Bacardi, 1 cl. whisky, 1 cl. lemon juice (saft / suyu), 2 cl. grenadine syrup, fill up, lemonade (gazoz), tranche lemon, pippette.
- 507  **SEX ON THE BEACH (Sh.)** Barantico Spc.  
Safari, Archer's, vodka, grenadine syrup, orange juice.
- 508 **SOUTHERN EXCITEMENT (Sh.)** Barantico Spc.  
2 cl. Southern Comfort Liqueur, (bourbon whisky & şeftali, portakal, bitki likörü), 2 cl. dry vermouth, 2 cl. brandy.
- 509 **SOUTHERN FARMER (Mg.)** Barantico Spc. / long drink  
4 cl. Southern Comfort Liqueur (bourbon whisky & şeftali, portakal, bitki likörü), 1 cl. brandy, fill up orange juice, pipette
- 510 **SPRING FEELING (Sh.)** Barantico Spc.  
3-4 ice, 1 bar sp. lemon juice, 1.5 cl. Chartreuse Green Liqueur, 3 cl. gin.
- 511  **TRAUM AUS ANTALYA (Sh.)** Forellenhau Spc.  
Fresh orange juice (saft / suyu) 1/1, 4 cl. Vodka, 1 cl. banana liqueur, 4 dashes grenadine syrup.

512  **GOOD NIGHT (Sh.)** Dr.Alijan Bayramov Spc. member of  
Barmen's Assotiation of Russia.

3-4 ice, 3cl. Malibu (likör), 3cl. Martini Bianco, Ananas juice (ananas suyu), 1 cocktail cherry (kokteyl kirazı/cocktailkirsche), lemon peel (spiral limon kabuğu).



513 **FINISH VIRGIN (Sh.)** Dr.Alijan Bayramov Spc.

5cl. vodka Smirnoff, 1b. spoon orange juice (1 bar kaşık portakal suyu), 1 b. spoon Amaretto di'Saronno (badem likörü), 1 b. spoon lemon juice (limon suyu), 1 cocktail cherry (kokteyl kirazı/cocktailkirsche)

514  **NEW GENERATION OF THE AHISKA (Sh.)** Dr.Alijan Bayramov Spc.  
Galiano 1,5cl.(likör), 1 cocktail cherry (kokteylkirazı/cocktailkirsche).  
with bar spoon:(Shake:3-4 ice, vodka Absolut Kurrant 3cl., milk 1cl.(süt), grenadine 1cl.(nar şurubu)), 1 1/2 bar sp.  
light cream (sahne / krem şanti).

515 **HUNTER (Mg.)** Dr.Alijan Bayramov Spc.

whisky Teacher's 6cl., cherry (likör/liguer) 4cl., 1 cocktail cherry (kokteylkirazı/cocktailkirsche), lemon peel (spiral limon kabuğu).

516  **PLAISIR DES ILES (Sh.)** Dr.Alijan Bayramov Spc.

3-4 ice, rum Bacardi 3cl., cocos syrup 1,5cl., pineapple juice 2cl. (ananas suyu), tranche pineapple & 1 cocktail cherry (kokteyl kirazı/cocktailkirsche) .

517 **HARRY'S PICK - ME-UP (Mg.)** Dr.Alijan Bayramov Spc.

3-4 ice, cognac Couirovsier 5cl., lemon juice 1cl., grenadine 2 dashes lemon peel (spiral limon kabuğu).

518  **FOG (Mg.)** Dr.Alijan Bayramov Spc.

3-4 ice, cognac Remi Martine 4cl., ginger ail 4cl., tranche lemon



519 **MARINA (Sh.)** Dr.Alijan Bayramov Spc.

3-4 ice, Malibu 3cl., Martini Bianco 3cl., mango juice 3cl., grenadine syrup 3-4 dash (nar şurubu), transhe lemon & 1 cocktail cherry (kokteyl kirazı / cocktailkirsche) .







520  **AMOUR MARINA (Sh.)** Dr.Alijan Bayramov Spc.







3-4 ice, gin Beefeater 3cl., liqueur Parfait Amour 1,5cl., Martini Extra dry 1,5cl., lemon peel (spiral limon kabuğu) & cocktails cherry (kokteyl kirazı/cocktailkirsche) .













- 521 **PEDIATRY** **Dr.Alijan Bayramov Spc.**  
 With bar spoon: **sugar syrup** 1/2cl. (şeker şurubu),  
 1 **cocktail cherry** (kokteyl kirazı / cocktailkirsche) ,  
 liqueur **Galliano** (vanilya bitki & baharat likörü)  
 1/2cl., liqueur **Blue Curaçao** 1/2cl.,  
**Martini Bitter** 1/2cl., **Cointreau** 5cl.
- 522 **MY FAIR LADY (Sh.)** **Dr.Alijan Bayramov Spc.**  
 3-4 ice, **gin Beefeater** 3cl., **orange juice** 1cl., **lemon juice** 1cl.,  
**white egg** 1(yumurta beyazı), **grenadine** 1-2 dash, **transhe**  
**lemon & 1cocktail cherry** (kokteyl kirazı / cocktailkirsche) .
- 523 **PARFAIT (Mg.)** **Dr.Alijan Bayramov Spc.**  
 3/4 ice, liqueur **Cointreau** 2cl. (portakal likörü),  
**white rum Bacardi** 2cl., **Brandy** 2cl., **lemon juice** 1cl.,  
**lemon peel** (spiral limon kabuğu),**tranche orange** (portakal).
- 524  **HEAVEN SO SWEET** **Dr.Alijan Bayramov Spc.**  
 With bar spoon: liqueur **Galliano** 1cl.,1**cocktail cherry**  
 (kokteyl kirazı/cocktailkirsche), liqueur  
**Amaretto di'Saronno** 1cl.(badem likörü), **vodkaSmirnoff** 4cl.
- 525 **LIGHT'S WINGS (Mg.)** **Dr.Alijan Bayramov Spc.**  
 3-4 ice, gin **Beeteater** 3cl., **Creme de Menthe** (nane likörü)  
 1,5cl., **transhe lemon & 1cocktail cherry**  
 (kokteyl kirazı / cocktailkirsche) .
- 526  **WHITE SPIDER (Mg.)** **Dr.Alijan Bayramov Spc.**  
 3-4 ice, **vodka Smirnoff** 3cl., **Creme de Menthe** (nane likörü)  
 3cl., **pepermint sprigs** 1(nane yaprakları / pfefferminze /  
 menthe /poivrée /menta, hierbabuena).
- 527  **BARFLY'S DREAM (Mg.)** **Dr.Alijan Bayramov Spc.**  
 3-4 ice, **vodka Smirnoff** 2cl., rum **Captain Morgan black** 2cl.,  
**pineapple juice** 2cl.(ananas suyu), 1**cocktail cherry**  
 (kokteyl kirazı/cocktailkirsche) & **lemon peel**  
 (spiral limon kabuğu).
- 528 **LIEBESTRAUM (Sh.)** **Dr.Alijan Bayramov Spc.**  
 3-4 ice, **Peach liqueur** 3cl. (şeftali likörü), **Blue Curaçao** 1cl.,,  
**Malibu** 2cl., **lemon juice** 1cl., **pineapple juice** 6cl.(ananas),  
**tranche pineapple & 1cocktail cherry** (kokteyl kirazı /  
 cocktailkirsche) .



- 529  **BIG GIRL (Sh.)** **Dr.Alijan Bayramov Spc.**  
3-4 ice, gin Beefeater 4cl., Martini Extra Dry 2cl., cherry juice 5cl.(vişne suyu), grenadine 1cl., 1 cocktail cherry (kokteyl kirazı cocktailkirsche) & lemon peel (spiral limon kabuğu).
- 530  **NIGHT KISS (Sh.)** **Dr.Alijan Bayramov Spc./ frappè.**  
3-4 ice, liqueur Bailey's 5cl., ice cream 3cl.(dondurma), Benedictine D.O.M. liqueur 2cl., grenadine 4-5 dash, 1 cocktail cherry (kokteylkirazı / cocktailkirsche).
- 531  **BLACK ROSÉ (Sh.)** **Dr.Alijan Bayramov Spc./ frappè.**  
3-4 ice, Benedictine D.O.M. liqueur 2cl., liqueur Kahlua 3cl.(kahve likörü), Brandy 2cl., crème de cacao liqueur 2cl., 2 bar sp. cream (sahne / rahm / krem şanti / crème fraiche / panna, ceram / Nata, crema).
- 532 **CHILDREN'S WINGS (Sh.)** **Dr.Alijan Bayramov Spc.**  
3-4 ice, ice cream 3cl.(dondurma), mango juice 3cl., grenadine 1/2 cl., banana juice 1cl., tranche banana & 1 cocktail cherry (kokteyl kirazı / cocktailkirsche).
- 533  **GREEN CHILDREN (Sh.)** **Dr.Alijan Bayramov Spc.**  
3-4 ice, ice cream 3cl.(dondurma), Blue Curaçao syrup 3 cl., milk 3cl.(süt), banana juice 1cl., pineapple juice 1cl., tranche pineapple & 1 cocktail cherry (kokteyl kirazı / cocktailkirsche) .
- 534 **THANK YOU, SERAP (Sh.)** **Dr.Alijan Bayramov Spc. / frappè.**  
3-4 ice, liqueur Galliano 2cl., rum Bacardi 2cl., ice cream 3cl.(dondurma), 2 bar sp. cream (sahne), orange Bitter 2 dash.
- 535 **UNCLE SAM (Sh.)** **Dr.Alijan Bayramov Spc.**  
3-4 ice, milk 1cl., liqueur de Chocolat Royal 2cl., white rum 3cl., banane juice 4cl., tranche banane.
- 536  **CHACIVER (Sh.)** **Dr.Alijan Bayramov Spc.**  
3-4 ice, liqueur de Chocolat Royal 2cl., white rum 3cl., pineapple juice 3cl., lemon juice 1cl., tranche pineapple & lemon peel (limon spiral kabuğu).
- 537  **SWEETY ASUMAN (Sh.)** **Dr.Alijan Bayramov Spc.**  
3-4 ice, liqueur de Chocolat Royal 2cl., cognac Courvosier 3cl., orange juice 5cl., tranche orange & 1 cocktail cherry (kokteyl kirazı / cocktailkirsche) .

- 538 **PINK FOREST (Sh.)** Dr.Alijan Bayramov Spc.  
3-4 ice, gin Gordon's 3cl., liqueur Triple Sec 1cl., liqueur Fraise Des Bois 6cl., cream 1bar spoon.
- 539  **REVE SATIN (Sh.)** Dr.Alijan Bayramov Spc.  
3-4 ice, liqueur Fraise Des Bois 5cl., liqueur Creme De Mure 5cl., 1bar spoon cream.
- 540 **RUE PINK (Mg.)** Dr.Alijan Bayramov Spc.  
Cognac Courvosier 1cl., liqueur Creme De Framboise 2cl., champagne 7cl., lemon peel (limon spiral kabuğu) & 1cocktail cherry (kokteyl kirazı / cocktailkirsche) .
- 541  **EXPRESS (Sh.)** Dr.Alijan Bayramov Spc.  
3-4 ice, cognac Courvosier 5cl., liqueur de Chocolat Royal 3cl., liqueur Creme De Menthe Verte 2cl., 1bar spoon cream & pepermint sprigs 1(nane yaprakları / pfefferminze / menthe / poivrée /menta, hierbabuena) & 1cocktail cherry (kokteyl kirazı / cocktailkirsche).
- 542  **ROYAL MINT (Mg.)** Dr.Alijan Bayramov Spc.  
Liqueur Mint's 1cl., vodka Smirnoff 2cl., champagne 7cl., pepermint sprigs 1(nane yaprakları / pfefferminze / menthe /poivrée /menta,hierbabuena).
- 543  **SUNSET VELVET (Sh.)** Şevki Eryiğit Spc.  
3-4 ice, safari 3cl., orange juice 6cl., grenadine 2cl., lemon juice 2cl., tranche orange & 1cocktail cherry (kokteyl kirazı / cocktailkirsche) .
- 544  **MONTANIA RAILWAY (Sh.)** Şevki Eryiğit Spc. long drink  
3-4 ice, tequila 4cl., gin Gordon's 2cl., Blue Curaçao 3cl., orange juice 5cl., lemon juice 1cl., tranche lemon & 1cocktail cherry (kokteyl kirazı / cocktailkirsche) .
- 545 **HI MAN (Mg.)** Şevki Eryiğit Spc.  
3-4 ice, Southern comfort 3cl., whisky Jack Daniel's 3cl., sprite 5cl.(gazoz), tonic 3cl., tranche orange (portakal).
- 546  **KISS OF JULIA (Sh.)** Şevki Eryiğit Spc.  
3-4 ice, vodka Smirnoff 5cl., liqueur Cointreau 2cl.(portakal likörü), lemon juice 1cl., orange juice 3cl., archer's 2cl., tranche orange & 1cocktail cherry (kokteyl kirazı / cocktailkirsche) .
- 547  **ABSOLBLUE (Sh.)** Şevki Eryiğit Spc.  
3-4 ice, vodka Absolut Citron 5cl., Blue Curaçao 2cl.,lemon juice 1cl., orange juice 3cl.,tranche orange, tranche apple & 1cocktail

- cherry (kokteylkirazı / cocktailkirsche) .
- 548  **JAMAICA SOUR (Sh.)** Şevki Eryiğit Spc. long drink  
3-4 ice, rum Bacardi 5cl., orange juice 3cl., orange Bitter 1dash,  
pineapple juice 2cl., lemon juice 1cl., tranche lemon.
- 549  **HORSE RADISH (Sh.)** Şevki Eryiğit Spc. long drink  
3-4 ice, vodka 6cl., tomato juice 3cl., tumip juice 3cl. (şalgam  
suyu),1d. tabasco(acisso), 1d. worchestershire sauce,1 bar sp.  
lemon juice, salt, pepper , tranche cucumber  
(hıyar / gurgen) & tranche lemon.
- 550 **IOB (Sh.)** Şevki Eryiğit Spc.  
3-4 ice, Irish whisky 4cl., Irish Mist 2cl., sprite 6cl.,  
tranche lemon.
- 551  **DELIGHT (Sh.)** Şevki Eryiğit Spc.  
3-4 ice, gin Gordon's 4cl., malibu 2cl., strawberry (erdbeere / çilek  
fraise) lemon juice 2cl., cherry juice 2cl., tranche lemon &  
1cocktail cherry (kokteylkirazı / cocktailkirsche) .
- 552  **YOU, MY PASSION (Sh.)** Şevki Eryiğit Spc.  
3-4 ice, Martini Bianco 3cl., Blue Curaçao 3cl., orange juice 2cl.,  
orange Bitter 1dash, 1cocktailcherry (kokteylkirazı / cocktailkirsche)
- 553 **I LOVE YOU, BABY (Sh.)**   
3-4 ice, vodka Absolut 2cl., Drambuei 2cl., Blue Curaçao 1cl.,  
milk 2cl.(süt),1cocktailcherry (kokteylkirazı / cocktailkirsche).
- 554 **BADE (Sh.)**   
3-4 ice, rum Bacardi 2cl., liqueur amaretto di saronno 2cl., liqueur  
Cacao 1cl., pineapple juice 1cl., lemon juice 1cl., orange juice 1cl.
- 555 **THE HONEY BEE (Sh.)**   
3-4 ice, malibu 2cl., liqueur de Banane1cl., orange juice 1cl.,  
pineapple juice 1cl., lemon juice 1cl., Blue Curaçao 1dash.
- 556  **NICE TIME (Sh.)**   
3-4 ice, malibu 1cl., liqueur de Banane1cl., Bailey's 1cl., orange  
juice 1cl., lemon juice 1cl.,1 cocktailcherry (kokteylkirazı /  
cocktailkirsche).
- 557 **RACING TEAM (Sh.)**  long drink  
3-4 ice, Brandy 2cl., Southern Comfort 2cl., Archer's 2cl., lemon  
juice 2cl., Angostura Bitter 3dash, Red Bull (fill up).

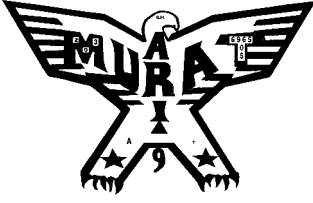

Barman Murat Arı Spc. Cocktails

### BOZA / HIRSEBIER / (non alcohol)

Mısır değirmende öğütülür. Su & şeker ilave edilerek 95°de kaynatılır, soğutulur. Püskürtme yapılır; tülbentle süzülerek boza haline gelir.

Mais wird in der mühle gemahlen. Wasser & zucker hirtzugeben & in 95° kochen lassen. Kalt wenden lassen (kalt stellen). Spritsen; vom tuch tülbent.

Grind corn in the mill. Add water & sugar & boilit to

95°C. Cool it spray; Drain through muslin till it becomes as thick as

zythum./ Mais wird in der Mühle gemahlen. Wasser & zucker hinzugeben & in 95°C kochen. Kalt werden lassen.

Spritsen & durch einem tuch sieben.

558

#### BOMA (Sh.)



3-4 ice, boza 6cl., Malibu 4cl., milk 3cl., Grenadine 4 dash 1 cocktailcherry (kokteylkirazi / cocktaillirsche). (Malibu yerine 10 dashes Coconut şurubu koyarsanız alkolsuz kokteyl olur).



559

#### BOLEY'S (Sh.)



3-4 ice, boza 6cl., liqueur Tia Maria 4cl.(kahve likörü), Brandy 2cl., milk 2cl., Bitter Chocolate 5 dash.



560

#### BOMOTO (Sh.)



3-4 ice, boza 6cl., liqueur amaretto di saronno 3cl., liqueur Tia Maria 2cl. milk 2cl..



561

#### BOMERETTO (Sh.)

3-4 ice, boza 6cl., liqueur amaretto di saronno 4cl., milk 2cl.



562

#### BOFARI (Sh.)

3-4 ice, boza 6cl., Safari 4cl.(kayısı likörü), milk 3cl..



563

#### BOCHIKO (Sh.)

3-4 ice, boza 6cl., vodka 3cl., Bitter Chocolate 3 dash, milk 2cl.

564

#### BONA (Sh.)



565



3-4 ice, boza 4cl., liqueur de Banane 4cl., milk 3cl., Grenadine 4 dash.(likörün yerine muz şurubu koysak, alkolsüz olur).

**BOTA (Sh.)**



3-4 ice, boza 6cl., After Shock (Cool Cinnamon) 4cl., milk 4cl., Grenadine 5 dashes.

### **MOKTAILS**

for kid's / çocuklar için, non alcohol cocktail's

Dr.Alijan Bayramov Spc.

Milk 2cl., coco syrup 2cl., ice cream 5cl., chocolate syrup 2cl. & cracked ice.

3-4 ice, ice cream 5cl., grenadine syrup 1,5cl., sprit 10cl.

3-4 ice, milk 5cl., white egg 1, framboise syrup 3cl.

3-4 ice, ice cream 5cl., blue curaçao syrup 2cl., peach juice 7cl.

3-4 ice, milk 5cl., grenadine syrup 1,5cl., zucker syrup 1,5cl., sprit 5cl.

3-4 ice, apple juice 5cl., lemon juice 1cl., zucker syrup 1,5cl., ice cream 5cl., grenadine 1/2 cl.

3-4 ice, apricot juice 5cl., cream 2cl., blue curaçao syrup 5dashes.

3-4 ice, white egg 1, pineapple juice 5cl., orange juice 5cl., cream 1cl., grenadine 2 d.



## REFERENCES / REFERENZEN / REFERANSLAR, KAYNAKLAR

**Gaige C.**, Crosby **Gaige's** : Cocktail Guide & Ladies' companion, 7 th ed. NewYork: M.Barrows & Co., 1949.

**Tour C.**, Handbuch für serviceangestellte, Luzern : Fachbuchverlag Union Helvetia,1976.

**Neiger E.**, Gastronomisches Wörterbuch, GER.

**Weinbrand**, Prof.Dr.Helmut **Arntz**, Wiesbaden / GER., 1978.

**Dries F.**, Getränke & Servierkunde, 3 rd edn. Gießen : Fachbuchverlag Dr. **Pfanneberg** & Co., 1979.

**Mr.Boston**, Official Bartender's Guide, E. **McCoy** & J.F.**Walker**, 1988, New York/U.S.A.

**Alois Dallmayr**, Weine. Spirituosen, München / GER., 1991.

Adnan **Mert**, **mixology & gastronomy / Barantico '2000. (turk.-eng.-deu.)**

Adnan **Mert** - Barantico, Geçmiş Yolculuk / Journey to the Past' 2016

Bu kitap turizm kültürüne katkı için basılmıştır.

This book is printed to contribute to tourism culture.

Dieses Buch wurde zu Gunsten der tourismuskultur gedruckt.

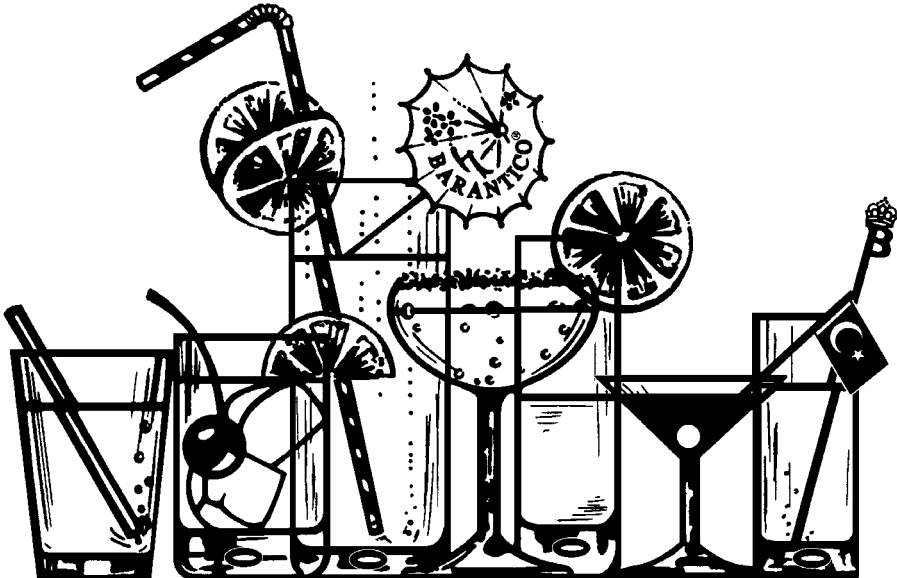

tasarım / design : Adnan Mert  
patent : Barantico tourism ltd. co.  
mod.: 200 / 01a  
pat. no.: 04599 Tr. 1998 00 724 Y



döner koltuk  
drehessel  
revolving chair



mod.: 200/ 03  
restaurant masa  
restaurant tisch  
restaurant table  
h.: 76 cm.  
Ø : 80 cm.  
80 x 80 cm.

mod.: 200/ 04  
bistro masa  
bistro tisch  
bistro table  
h.: 110cm.  
Ø : 80 cm.  
80 x 80 cm.



mod.: 200 / 01b  
bar koltuk  
barhocker  
h.: 80 cm.





döner milli modüler şaraphlık



mod.: 300/01  
réchaud "rešo" / ısıtıcı / hotplate.  
h.: 6.5 cm.  
17 x 23 cm.

yemeğiniz aynı lezzet & sıcaklıkta saatlerce kalacaktır.  
das essen bleibt stundenlang köstlich & warm.  
let your meal preserve its taste & warmth ( over the réchaud)







mod.: 200 / 06  
h.: 198 cm.  
döner portmanto  
drech garderobenständer  
revolving hat - stand



mod.: 400 / 01  
h.: 240 cm. / 99 x 135 x 52 cm.  
bira & meşrubat ünitesi (seyyar, modüler)  
beer / bier & cold drinks unit. (portable, moduler)





Adnan Mert







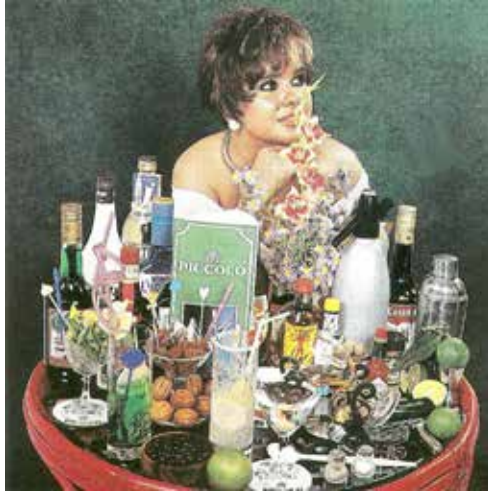



cocktail KC-25 (Der Kniekehlencocktail -1925)  
"diz arkası çukuru kokteyl"



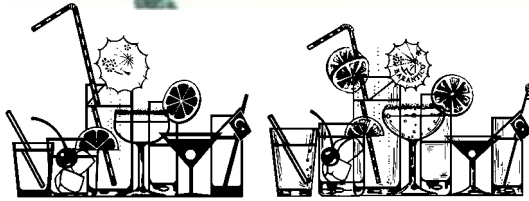













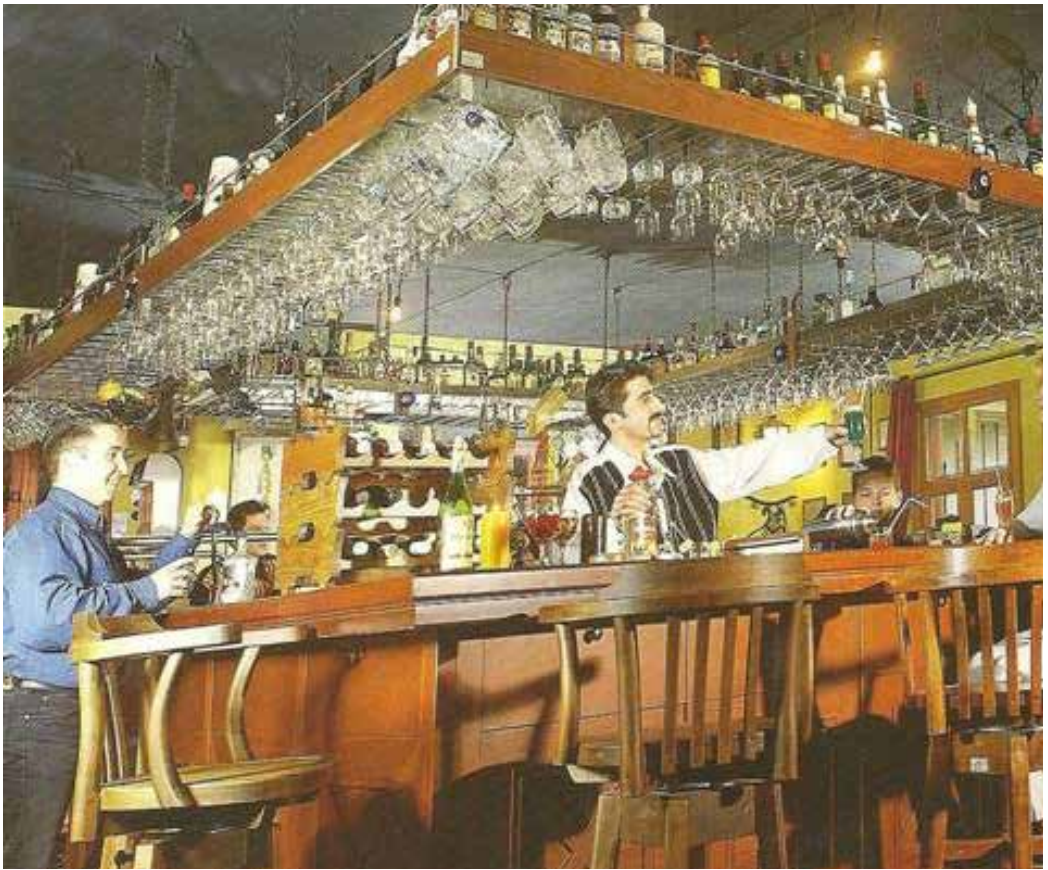

















M. Muhammed Arslan /B.B.D. Lokali















Adnan Mert Barantico



Sirket-i Hayriye döneminde(1854-1944) 90 yıllık bir süre zarfında vapurlarda alkollü içki satışı serbestmiş. Kurum, 1945'te devletleştirilip Türkiye Denizcilik İşletmeleri olduktan sonra da vapurlara kademeli olarak konan içki yasası, İstanbulluları bu adetten vazgeçirememiş. Özellikle vapurların küçük kısmı nevalesiyle gelen içkiciler tarafından kullanılmaya devam edilmiş. Padişah 2. Abdulhamid döneminde bu vapurlarda rakı, yerli ve yabancı biralar, vermut, viski, brendi, konyak, hatta rum işi reçineli şarap bile bulunmuş. Küçük kadehlerde verilen içkilere çay tabağında sunulan mezeler eşlik edermiş: kaşar, edirne peyniri, sardalya, salamura biber, kalamata zeytin, sucuk, pastırma dilimleri, patlıcan kızartma, ezme, kornişon, sakı leblebisi, badem, füme ringa balığı filetoları. Her kadehten sonra bu mezeler tazelenirmiş. Aşağıdaki güzel şişe de denizyolları için üretilmiş...

00:45





# **Geçmiş Yolculuk** **Journey To The Past**

**ADNAN MERT BARANTICO**

**Prusias - Prusia - Prusa**  
**BURSA**

**Adnan Mert Barantico**











# MIXOLOGY & GASTRONOMY

ADNAN MERT BARANTICO



ISBN. : 975 - 94912 - 1 - 4